



. . . c o n n e c t i n g y o u r b u s i n e s s

LANCOM GS-2326 User Manual

LANCOM
Systems

Contents

1 Introduction.....	7
1.1 Overview.....	7
2 Operation of Web-based Management.....	8
2.1 Connecting network devices.....	10
2.2 Twisted-pair devices.....	10
2.3 Cabling guidelines.....	10
3 Configuration.....	11
3.1 Port.....	11
3.1.1 Configuration.....	11
3.1.2 Port Description.....	12
3.1.3 Traffic Overview	13
3.1.4 Detailed Statistics	14
3.1.5 QoS Statistics	16
3.1.6 EEE.....	17
3.1.7 SFP Information	18
3.2 ACL.....	20
3.2.1 Ports.....	20
3.2.2 Rate Limiters.....	21
3.2.3 Access Control List.....	22
3.2.4 ACL Status.....	25
3.3 Aggregation.....	27
3.3.1 Static Trunk.....	27
3.3.2 LACP.....	29
3.4 Spanning Tree.....	32
3.4.1 Bridge Settings.....	32
3.4.2 MSTI Mapping.....	34
3.4.3 MSTI Priorities.....	35
3.4.4 CIST Ports.....	36
3.4.5 MSTI Ports.....	38
3.4.6 Bridge Status.....	39
3.4.7 Port Status.....	40
3.4.8 Port Statistics.....	41
3.5 IGMP Snooping.....	42
3.5.1 Basic Configuration.....	42
3.5.2 VLAN Configuration.....	44
3.5.3 Port Group Filtering.....	45
3.5.4 Status.....	46
3.5.5 Group Information.....	48
3.5.6 IPv4 SSM information.....	49
3.6 MLD Snooping.....	50

3.6.1 Basic Configuration.....	50
3.6.2 VLAN Configuration.....	52
3.6.3 Port Group Filtering.....	53
3.6.4 Status.....	54
3.6.5 Group Information.....	55
3.6.6 IPv6 SSM Information.....	56
3.7 MVR.....	57
3.7.1 Configuration.....	57
3.7.2 Groups Information.....	58
3.7.3 Statistics.....	59
3.8 LLDP.....	60
3.8.1 LLDP Configuration.....	60
3.8.2 LLDP Neighbors.....	62
3.8.3 LLDP-MED Configuration.....	64
3.8.4 LLDP-MED Neighbors.....	70
3.8.5 EEE.....	72
3.8.6 Port Statistics.....	74
3.9 Filtering Data Base.....	75
3.9.1 Configuration.....	75
3.9.2 Dynamic MAC Table.....	77
3.10 VLAN.....	79
3.10.1 VLAN Membership	79
3.10.2 Ports	80
3.10.3 Switch Status	81
3.10.4 Port Status.....	82
3.10.5 Private VLANs.....	84
3.10.6 MAC-based VLAN.....	85
3.10.7 Protocol-based VLAN.....	87
3.11 Voice VLAN.....	90
3.11.1 Configuration.....	90
3.11.2 OUI.....	92
3.12 GARP.....	93
3.12.1 Configuration.....	93
3.12.2 Statistics	94
3.13 GVRP.....	95
3.13.1 Configuration.....	95
3.13.2 Statistics	96
3.14 QoS.....	97
3.14.1 Port Classification	98
3.14.2 Port Policing	99
3.14.3 Port Scheduler	100
3.14.4 Port Shaping.....	103
3.14.5 Port Tag Remarking	105
3.14.6 Port DSCP.....	107

3.14.7 DSCP-Based QoS.....	108
3.14.8 DSCP Translation	110
3.14.9 DSCP Classification	111
3.14.10 QoS Control List Configuration.....	112
3.14.11 QCL Status	115
3.14.12 Storm Control.....	117
3.14.13 WRED.....	117
3.15 Thermal Protection.....	119
3.15.1 Configuration.....	119
3.15.2 Status.....	120
3.16 s-Flow Agent.....	120
3.16.1 Collector	120
3.16.2 Sampler	122
3.17 Loop Protection.....	123
3.17.1 Configuration	123
3.17.2 Status	125
3.18 Easy Port.....	125
3.19 Mirroring	127
3.20 Trap Event Severity	128
3.21 SMTP Configuration	129
3.22 UPnP	130
4 System Configuration.....	132
4.1 System Information.....	132
4.1.1 Information.....	132
4.1.2 Configuration.....	133
4.1.3 CPU Load.....	134
4.2 Time.....	135
4.2.1 Manual.....	135
4.2.2 NTP.....	137
4.3 Account.....	137
4.3.1 Users.....	138
4.3.2 Privilege Level.....	139
4.4 IP.....	140
4.4.1 IPv4	140
4.4.2 IPv6	141
4.5 Syslog.....	142
4.5.1 Configuration.....	142
4.5.2 Log.....	143
4.5.3 Detailed Log.....	144
4.6 SNMP.....	145
4.6.1 System.....	145
4.6.2 Communities.....	146
4.6.3 Users.....	147
4.6.4 Groups.....	149

4.6.5 Views.....	150
4.6.6 Access.....	151
4.6.7 Trap.....	152
5 Security.....	154
5.1 IP Source Guard.....	154
5.1.1 Configuration.....	154
5.1.2 Static Table.....	155
5.1.3 Dynamic Table.....	156
5.2 ARP Inspection.....	157
5.2.1 Configuration.....	157
5.2.2 Static Table.....	158
5.2.3 Dynamic Table.....	159
5.3 DHCP Snooping.....	159
5.3.1 Configuration.....	159
5.3.2 Statistics.....	160
5.4 DHCP Relay.....	162
5.4.1 Configuration.....	162
5.4.2 Statistics.....	163
5.5 NAS.....	164
5.5.1 Configuration.....	165
5.5.2 Switch Status.....	171
5.5.3 Port Status.....	172
5.6 AAA.....	174
5.6.1 Configuration.....	174
5.6.2 Radius Overview.....	177
5.6.3 Radius Details.....	179
5.7 Port Security.....	179
5.7.1 Limit Control.....	180
5.7.2 Switch Status.....	182
5.7.3 Port Status.....	183
5.8 Access Management.....	184
5.8.1 Configuration.....	184
5.8.2 Statistics.....	186
5.9 SSH.....	186
5.10 HTTPs.....	187
5.11 Auth Method.....	188
6 Maintenance.....	189
6.1 Restart Device.....	189
6.2 Firmware	189
6.2.1 Firmware Upgrade.....	189
6.2.2 Firmware Selection.....	190
6.3 Save / Restore.....	191
6.3.1 Factory Defaults.....	191
6.3.2 Save Start.....	192

6.3.3 Save User.....	192
6.3.4 Restore User.....	193
6.4 Export / Import.....	193
6.4.1 Export Config.....	193
6.4.2 Import Config.....	194
6.5 Diagnostics.....	195
6.5.1 Ping.....	195
6.5.2 Ping6.....	196
6.5.3 VeriPHY.....	197
A. Glossary of Web-based Management.....	199
A	199
C	200
D	200
E	201
F	202
H	202
I	203
L	204
M	204
N	205
O	206
P	206
Q	207
R	208
S	208
T	209
U	210
V	210

1 Introduction

1.1 Overview

In this user's manual, it will not only show how to install and connect your network system but how to configure and monitor the GS-2300 series by (RS-232) serial interface or through the web and ethernet ports step-by-step, too. Many detailed explanations of hardware and software functions are shown as well as examples of the operation for the web-based interface.

The GS-2300 series, the next generation of web-managed switches from LANCOM, is a portfolio of affordable managed switches that provides a reliable infrastructure for your business network. These switches deliver more intelligent features to improve the availability of your critical business applications, protect your sensitive information, and optimize your network bandwidth to deliver information and applications more effectively. It provides the ideal combination of affordability and capabilities for entry level networking includes small business or enterprise application and helps you create a more efficient, better-connected workforce.

The GS-2352 web managed switch provides 52 ports in a single device. Additional highlights:

L2+ features provide better manageability, security, QoS, and performance.

High port count design with all Gigabit Ethernet ports

Supports guest VLAN, voice VLAN, port-based, tag-based and protocol-based VLANs.

Supports 802.3az energy efficient ethernet standard

Supports 8K MAC table

Supports IPv6/ IPv4 dual stack

Supports s-Flow

Supports Easy-Configuration-Port for easy implementation in the IP Phone, IP Camera or Wireless environment.

2 Operation of Web-based Management

Initial Configuration

This chapter instructs you how to configure and manage the GS-2300 series through the web user interface. With this facility, you can easily access and monitor through any one port of the switch all the status of the switch, including MIBs status, each port activity, spanning tree status, port aggregation status, multicast traffic, VLAN and priority status, illegal access record, etc.

The default values of the GS-2300 series are listed in the table below:

IP Address	172.23.56.250
Subnet Mask	255.255.255.0
Default Gateway	172.23.56.254
Username	admin
Password	admin

After the switch has finished the configuration of the interface, you can browse it. For instance, type `http://172.23.56.250` in the address row in a browser, it will show the following screen and ask you to input your username and password in order to login and access authentication.

The default username is "admin" and the password is "admin". For the first time, please use the default username and password, and then click the <Login> button. The login process now is completed. In the login menu, you have to use the complete username and password respectively, the GS-2300 series will not give you a shortcut to a username automatically. This looks inconvenient, but is more secure.

In the GS-2300 series, the user management allows only one administrator to configure the system at the same time. If there are two or more users using administrator access, it will allow the one who logs in first to configure the system. The rest of the users, even with administrator access, can only monitor the system. Those who have no administrator access can only monitor the system regardless. Only a maximum of three users are able to login simultaneously in the GS-2300 series.



When you first login on the Switch using the web to manage you must use the Username "admin". Default password is "admin".

Both IPv4 and IPv6 is supported for management functions.

To optimize the display effect, we recommend you use Microsoft IE 6.0 above, Netscape V7.1 above or Firefox V1.00 above and have a resolution of 1024x768. The switch supports a neutral web browser interface.



The GS-2300 series is set to DHCP by default. If you do not have a DHCP server to provide an ip address to the switch, the default ip is 172.23.56.250



 The image shows the 'System Information' page in the LANCOM GS-2352 web management interface. The page has a blue header with the LANCOM logo and 'GS-2352'. A navigation menu on the left includes System, System Information, Configuration, Security, and Maintenance. The main content area displays a table of system information.

System Information	
Model Name	LANCOM GS-2352
System Description	52-Port Layer-2 Plus Managed Gigabit Ethernet Switch with 4x 10G SFP+
Location	e213
Contact	
Device Name	QS-MPlum-GS-2352
System Date	2012-05-03 16:36:08
System Uptime	6d 00:42:48
BIOS Version	v1.00
Firmware Version	v1.30
Hardware-Mechanical Version	v1.01-v1.01
Series Number	033B02000001
Host IP Address	10.99.8.55
Subnet Mask	255.255.255.0
Gateway IP Address	10.99.8.11
Host MAC Address	00-40-c7-1c-6c-e0
Console Baudrate	115200
RAM Size	128MB
Flash Size	16MB
Bridge FDB Size	8192 MAC Addresses
Transmit Queue	8 queues per port
Maximum Frame Size	10056
Fan Speed	5791 (rpm) / 6024 (rpm)
AC Power	12.47 V
DC Power	0 V
Temperature	41C (105.8F) / 40C (104.0F)

System Information Help

The switch system information is provided here.

Contact

The system contact configured in Configuration | System | Information | System Contact.

Name

The system name configured in Configuration | System | Information | System Name.

Location

The system location configured in Configuration | System | Information | System Location.

MAC Address

The MAC Address of this switch.

Chip ID

The Chip ID of this switch.

System Date

2.1 Connecting network devices

The switch is designed to be connected to 10, 100 or 1000Mbps network cards in PCs and servers, as well as to other switches and hubs. It may also be connected to remote devices using optional SFP transceivers.

2.2 Twisted-pair devices

Each device requires an unshielded twisted-pair (UTP) cable with RJ45 connectors at both ends. Use Category 5, 5e or 6 cable for 1000BASE-T connections, Category 5 or better for 100BASE-TX connections.

2.3 Cabling guidelines

The RJ45 ports on the switch support automatic MDI/MDI-X pin-out configuration, so you can use standard straight-through twisted-pair cables to connect to any other network device (PCs, servers, switches, routers, or hubs).

See Appendix B for further information on cabling.

 **CAUTION:** Do not plug a phone jack connector into an RJ45 port. This will damage the switch. Use only twisted-pair cables with RJ45 connectors that conform to FCC standards.

CONNECTING TO PCS, SERVERS, HUBS AND SWITCHES

Step 1: Attach one end of a twisted-pair cable segment to the device's RJ45 connector.

Figure 16: Making Twisted-Pair Connections

Step 2: If the device is a network card and the switch is in the wiring closet, attach the other end of the cable segment to a modular wall outlet that is connected to the wiring closet. (See the section "Network Wiring Connections.") Otherwise, attach the other end to an available port on the switch.

Make sure each twisted pair cable does not exceed 100 meters (328 ft) in length.

 Avoid using flow control on a port connected to a hub unless it is actually required to solve a problem. Otherwise back pressure jamming signals may degrade overall performance for the segment attached to the hub.

Step 3: As each connection is made, the Link LED (on the switch) corresponding to each port will light green (1000 Mbps) or amber (100 Mbps) to indicate that the connection is valid.

NETWORK WIRING CONNECTIONS

Today, the patch-down block is an integral part of many of the newer equipment racks. It is actually part of the patch panel. Instructions for making connections in the wiring closet with this type of equipment follows.

Step 1: Attach one end of a patch cable to an available port on the switch, and the other end to the patch panel.

Step 2: If not already in place, attach one end of a cable segment to the back of the patch panel where the punch-down block is located, and the other end to a modular wall outlet.

Step 3: Label the cables to simplify future troubleshooting. See "Cable Labeling and Connection Records".

Figure 17: Network Wiring Connections

3 Configuration

This chapter describes all of the basic network configuration tasks which include the Ports, Layer 2 network protocol (e.g. VLANs, QoS, IGMP, ACLs, and PoE, etc.) and any setting of the Switch.

3.1 Port

The section describes how to configure the Port detail parameters of the switch. You can use the Port configuration to monitor, enable, or disable the ports of the switch.

3.1.1 Configuration

This chapter describes how to view the current port configuration and how to configure ports to non-default settings, including

Linkup/Linkdown

Speed (Current and configured)

Flow Control (Current Rx, Current Tx and Configured)

Maximum Frame Size

Excessive Collision Mode

Power Control.

Web Interface

To configure a Port in the web interface:

1. Click Configuration, Port, then Configuration
2. Specify the Speed Configured, Flow Control, Maximum Frame size, Excessive Collision mode, and Power Control.
3. Click Save.

Figure 3-1.1: The Port Configuration

Port Configuration Refresh										
Port	Link	Speed		Flow Control			Maximum Frame Size	Excessive Collision Mode	Power Control	
		Current	Configured	Current Rx	Current Tx	Configured				
*			<>			<input type="checkbox"/>	10056	<>	<>	
1	●	1Gfdx	Auto	×	×	<input type="checkbox"/>	10056	Discard	Disabled	
2	●	Down	Auto	×	×	<input type="checkbox"/>	10056	Discard	Disabled	
3	●	Down	Auto	×	×	<input type="checkbox"/>	10056	Discard	Disabled	
4	●	Down	Auto	×	×	<input type="checkbox"/>	10056	Discard	Disabled	
45	●	Down	SFP_Auto_AMS	×	×	<input type="checkbox"/>	10056	Discard	Disabled	
46	●	Down	SFP_Auto_AMS	×	×	<input type="checkbox"/>	10056	Discard	Disabled	
47	●	Down	SFP_Auto_AMS	×	×	<input type="checkbox"/>	10056	Discard	Disabled	
48	●	Down	SFP_Auto_AMS	×	×	<input type="checkbox"/>	10056	Discard	Disabled	
49	●	Down	10Gbps FDX	×	×	<input type="checkbox"/>	10056			
50	●	Down	10Gbps FDX	×	×	<input type="checkbox"/>	10056			
51	●	Down	10Gbps FDX	×	×	<input type="checkbox"/>	10056			
52	●	Down	10Gbps FDX	×	×	<input type="checkbox"/>	10056			

Save Reset

Parameter description:

Port:

The logical port number for this row.

Link:

The current link state is displayed graphically. Green indicates the link is up and red that it is down.

Current Link Speed:

Provides the current link speed of the port.

Configured Link Speed:

Select any available link speed for the given switch port.

Auto Speed selects the highest speed that is compatible with a link partner.

Disabled disables the switch port operation.

Flow Control:

When Auto Speed is selected on a port, this section indicates the flow control capability that is advertised to the link partner. When a fixed-speed setting is selected, that is what is used. The Current Rx column indicates whether pause frames on the port are obeyed, and the Current Tx column indicates whether pause frames on the port are transmitted. The Rx and Tx settings are determined by the result of the last Auto-Negotiation.

Check the configured column to use flow control. This setting is related to the setting for Configured Link Speed.

Maximum Frame Size:

Enter the maximum frame size allowed for the switch port, including FCS.

Excessive Collision Mode:

Configure port transmit collision behavior.

Discard: Discard frame after 16 collisions (default).

Restart: Restart backoff algorithm after 16 collisions.

Power Control:

The Usage column shows the current percentage of the power consumption per port. The Configured column allows for changing the power savings mode parameters per port.

Disabled: All power savings mechanisms disabled.

ActiPHY: Link down power savings enabled.

PerfectReach: Link up power savings enabled.

Enabled: Both link up and link down power savings enabled.

Buttons:

Save – Click to save changes.

Reset – Click to undo any changes made locally and revert to previously saved values.

Refresh – Refresh the ports link status manually

3.1.2 Port Description

This section describes how to configure the port's alias or any descriptions for the ports identity. It provides user the option to enter an alphanumeric string describing the full name and/or additional information, eg the usage of the port.

Web Interface

To enter a Port Description in the web interface:

1. Click Configuration, Port, then Port Description
2. Specify the detail port alias or description.
3. Click Save.

Figure 3-1.2: The Port Configuration

Port	Description
1	
2	
3	
4	
5	
6	
7	
8	
9	
10	
11	
12	
13	
14	
15	
16	
17	
18	
19	
20	
21	
22	
23	
24	
25	
26	
27	
28	
29	
30	
31	
32	
33	
34	
35	
36	
37	
38	
39	
40	
41	
42	
43	
44	
45	
46	
47	
48	
49	
50	
51	
52	

Apply Reset

Parameter description:

Port:

The logical port number for this row.

Description:

The description of device ports must not include " # % & ' + \.

Buttons

Apply – Click to save changes.

Reset – Click to undo any changes made locally and revert to previously saved values.

3.1.3 Traffic Overview

This section describes the port statistics information and provides an overview of general traffic statistics for all switch ports.

Web Interface

To display the Port Statistics Overview in the web interface:

1. Click Configuration, Port, then Traffic Overview
2. If you want to auto-refresh, you need to activate "Auto-refresh".
3. Click "Refresh" to refresh the port statistics or click "Clear" to clear all information.

Figure 3-1.3: The Port Statistics Overview

Port Statistics Overview										Auto-refresh <input type="checkbox"/>	Refresh	Clear
Port	Packets		Bytes		Errors		Drops		Filtered	Received		
	Received	Transmitted	Received	Transmitted	Received	Transmitted	Received	Transmitted				
1	4983	4107	983354	2622602	0	0	0	0	0	0		
2	0	0	0	0	0	0	0	0	0	0		
3	0	0	0	0	0	0	0	0	0	0		
4	0	0	0	0	0	0	0	0	0	0		
5	0	0	0	0	0	0	0	0	0	0		
6	0	0	0	0	0	0	0	0	0	0		
7	0	0	0	0	0	0	0	0	0	0		
8	0	0	0	0	0	0	0	0	0	0		
9	0	0	0	0	0	0	0	0	0	0		
10	0	0	0	0	0	0	0	0	0	0		
11	0	0	0	0	0	0	0	0	0	0		
12	0	0	0	0	0	0	0	0	0	0		
13	0	0	0	0	0	0	0	0	0	0		
14	0	0	0	0	0	0	0	0	0	0		
15	0	0	0	0	0	0	0	0	0	0		
16	0	0	0	0	0	0	0	0	0	0		
17	0	0	0	0	0	0	0	0	0	0		
18	0	0	0	0	0	0	0	0	0	0		
19	0	0	0	0	0	0	0	0	0	0		
20	0	0	0	0	0	0	0	0	0	0		

Parameter description:

Port

The logical port for the settings contained in the same row.

Packets

The number of received and transmitted packets per port.

Bytes

The number of received and transmitted bytes per port.

Errors

The number of frames received in error and the number of incomplete transmissions per port.

Drops

The number of frames discarded due to ingress or egress congestion.

Filtered

The number of received frames filtered by the forwarding

Auto-refresh

Activate the auto-refresh to refresh the information automatically.

Refresh

Refresh the Port Statistics information.

Clear

Clean up all Port Statistics.

3.1.4 Detailed Statistics

The section describes how to provide detailed traffic statistics for a specific switch port. Use the port select box to select which switch port details to display.

The displayed counters are the totals for receive and transmit, the size counters for receive and transmit, and the error counters for receive and transmit.

Web Interface

To display the per Port detailed Statistics Overview in the web interface:

1. Click Configuration, Port, then Detailed Port Statistics
2. Scroll the Port Index to select which port you want to show the detailed Port statistics overview.
3. If you want to auto-refresh the information then you need to activate "Auto-refresh".
4. Click " Refresh" to refresh the port detailed statistics or click "Clear" to clear all information.

Figure 3-1.4: The Detailed Port Statistics

Detailed Port Statistics Port 1			
Port 1		Auto-refresh <input type="checkbox"/>	Refresh Clear
Receive Total		Transmit Total	
Rx Packets	7637	Tx Packets	10688
Rx Octets	1518566	Tx Octets	3337459
Rx Unicast	7183	Tx Unicast	4974
Rx Multicast	29	Tx Multicast	5714
Rx Broadcast	425	Tx Broadcast	0
Rx Pause	0	Tx Pause	0
Receive Size Counters		Transmit Size Counters	
Rx 64 Bytes	4761	Tx 64 Bytes	72
Rx 65-127 Bytes	200	Tx 65-127 Bytes	5380
Rx 128-255 Bytes	86	Tx 128-255 Bytes	2866
Rx 256-511 Bytes	2588	Tx 256-511 Bytes	97
Rx 512-1023 Bytes	2	Tx 512-1023 Bytes	2139
Rx 1024-1526 Bytes	0	Tx 1024-1526 Bytes	134
Rx 1527- Bytes	0	Tx 1527- Bytes	0
Receive Queue Counters		Transmit Queue Counters	
Rx Q0	7637	Tx Q0	0
Rx Q1	0	Tx Q1	0
Rx Q2	0	Tx Q2	0
Rx Q3	0	Tx Q3	0
Rx Q4	0	Tx Q4	0
Rx Q5	0	Tx Q5	0
Rx Q6	0	Tx Q6	0
Rx Q7	0	Tx Q7	10688

Parameter description:

Auto-refresh:

To activate the auto-refresh to refresh the Port Statistics information automatically.

Upper left scroll bar:

To scroll which port to display the Port statistics with "Port-0", "Port-1"...

Receive Total and Transmit Total

Rx and Tx Packets:

The number of received and transmitted (good and bad) packets.

Rx and Tx Octets:

The number of received and transmitted (good and bad) bytes. Includes FCS, but excluding framing bits.

Rx and Tx Unicast

The number of received and transmitted (good and bad) unicast packets.

Rx and Tx Multicast:

The number of received and transmitted (good and bad) multicast packets.

Rx and Tx Broadcast:

The number of received and transmitted (good and bad) broadcast packets.

Rx and Tx Pause:

3 Configuration

A count of the MAC Control frames received or transmitted on this port that have an opcode indicating a PAUSE operation.

Receive and Transmit Size Counters

The number of received and transmitted (good and bad) packets split into categories based on their respective frame sizes.

Receive and Transmit Queue Counters

The number of received and transmitted packets per input and output queue.

Receive Error Counters

Rx Drops:

The number of frames dropped due to lack of receive buffers or egress congestion.

Rx CRC/Alignment:

The number of frames received with CRC or alignment errors.

Rx Undersize:

The number of short 1 frames received with valid CRC.

Rx Oversize:

The number of long 2 frames received with valid CRC.

Rx Fragments:

The number of short 1 frames received with invalid CRC.

Rx Jabber:

The number of long 2 frames received with invalid CRC.

Rx Filtered:

The number of received frames filtered by the forwarding process.

Short frames are frames that are smaller than 64 bytes.

Long frames are frames that are longer than the configured maximum frame length for this port.

Transmit Error Counters

Tx Drops:

The number of frames dropped due to output buffer congestion.

Tx Late/Exc. Coll.:

The number of frames dropped due to excessive or late collisions.

Auto-refresh:

To activate the auto-refresh to refresh the Queuing Counters automatically.

Refresh

Refresh the detailed port statistics manually.

Clear

Clear the detailed port statistics manually.

3.1.5 QoS Statistics

The section describes that switch could display the QoS detailed Queuing counters for a specific switch port. for the different queues for all switch ports.

Web Interface

To display the Queuing Counters in the web interface:

1. Click Configuration, Port, then QoS Statistics
2. If you want to auto-refresh the information then you need to activate "Auto-refresh".
3. Click "Refresh" to refresh the Queuing Counters or click "Clear" to clear all information.

Figure 3-1.5: The Queuing Counters Overview

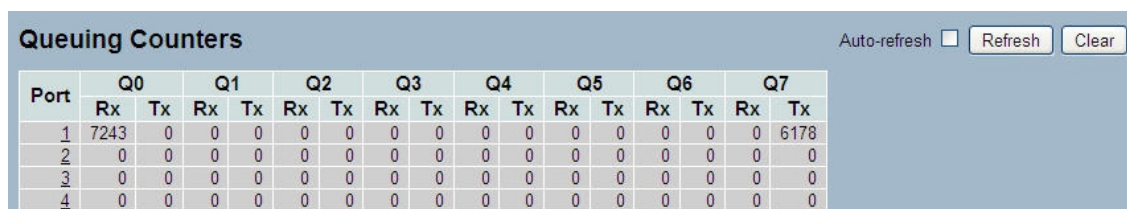

Port	Q0		Q1		Q2		Q3		Q4		Q5		Q6		Q7		
	Rx	Tx	Rx	Tx	Rx	Tx	Rx	Tx	Rx	Tx	Rx	Tx	Rx	Tx	Rx	Tx	
1	7243	0	0	0	0	0	0	0	0	0	0	0	0	0	0	0	6178
2	0	0	0	0	0	0	0	0	0	0	0	0	0	0	0	0	0
3	0	0	0	0	0	0	0	0	0	0	0	0	0	0	0	0	0
4	0	0	0	0	0	0	0	0	0	0	0	0	0	0	0	0	0

Parameter description:

Port:

The logical port for the settings contained in the same row.

Qn:

Qn is the Queue number, QoS queues per port. Q0 is the lowest priority queue.

Rx/Tx:

The number of received and transmitted packets per queue.

Auto-refresh:

To activate the auto-refresh to refresh the Queuing Counters automatically.

Refresh

Refresh the Queuing Counters manually.

Clear

Clear the Queuing Counters manually.

3.1.6 EEE

EEE is a power saving option that reduces the power usage when there is very low traffic utilization (or no traffic).

EEE works by powering down circuits when there is no traffic. When a port gets data to be transmitted all circuits are powered up. The time it takes to power up the circuits is named wakeup time. The default wakeup time is 17 us for 1Gbit links and 30 us for other link speeds. EEE devices must agree upon the value of the wakeup time in order to make sure that both the receiving and transmitting device has all circuits powered up when traffic is transmitted. The devices can exchange information about the devices wakeup time using the LLDP protocol.

For maximizing the power saving, the circuit isn't started at once transmit data are ready for a port, but is instead queued until 3000 bytes of data are ready to be transmitted. For not introducing a large delay in case that data less than 3000 bytes shall be transmitted, data are always transmitted after 48 us, giving a maximum latency of 48 us + the wakeup time.

If desired it is possible to minimize the latency for specific frames, by mapping the frames to a specific queue (done with QOS), and then mark the queue as an urgent queue. When an urgent queue gets data to be transmitted, the circuits will be powered up at once and the latency will be reduced to the wakeup time.

Web Interface

To configure EEE in the web interface:

3 Configuration

1. Click Configuration, Port, then EEE
2. To evoke which port wants to enable the EEE function.
3. EEE Urgent Queues level and the range from 1 to 8. the queue will postpone the transmission until 3000 bytes are ready to be transmitted.
4. Click Save.

Figure: EEE Configuration

EEE Configuration									
Port	EEE Enabled	EEE Urgent Queues							
		1	2	3	4	5	6	7	8
*	<input type="checkbox"/>	<input type="checkbox"/>	<input type="checkbox"/>	<input type="checkbox"/>	<input type="checkbox"/>	<input type="checkbox"/>	<input type="checkbox"/>	<input type="checkbox"/>	<input type="checkbox"/>
1	<input type="checkbox"/>	<input type="checkbox"/>	<input type="checkbox"/>	<input type="checkbox"/>	<input type="checkbox"/>	<input type="checkbox"/>	<input type="checkbox"/>	<input type="checkbox"/>	<input type="checkbox"/>
2	<input type="checkbox"/>	<input type="checkbox"/>	<input type="checkbox"/>	<input type="checkbox"/>	<input type="checkbox"/>	<input type="checkbox"/>	<input type="checkbox"/>	<input type="checkbox"/>	<input type="checkbox"/>
3	<input type="checkbox"/>	<input type="checkbox"/>	<input type="checkbox"/>	<input type="checkbox"/>	<input type="checkbox"/>	<input type="checkbox"/>	<input type="checkbox"/>	<input type="checkbox"/>	<input type="checkbox"/>
22	<input type="checkbox"/>	<input type="checkbox"/>	<input type="checkbox"/>	<input type="checkbox"/>	<input type="checkbox"/>	<input type="checkbox"/>	<input type="checkbox"/>	<input type="checkbox"/>	<input type="checkbox"/>
23	<input type="checkbox"/>	<input type="checkbox"/>	<input type="checkbox"/>	<input type="checkbox"/>	<input type="checkbox"/>	<input type="checkbox"/>	<input type="checkbox"/>	<input type="checkbox"/>	<input type="checkbox"/>
24	<input type="checkbox"/>	<input type="checkbox"/>	<input type="checkbox"/>	<input type="checkbox"/>	<input type="checkbox"/>	<input type="checkbox"/>	<input type="checkbox"/>	<input type="checkbox"/>	<input type="checkbox"/>

Apply Reset

Parameter description:

Port:

The switch port number of the logical EEE port.

EEE Enabled:

Controls if EEE is enabled for this switch port.

EEE Urgent Queues:

Queues set will activate transmission of frames as soon as any data is available. Otherwise the queue will postpone the transmission until 3000 bytes are ready to be transmitted.

Buttons:

Apply – Click to save changes.

Reset – Click to undo any changes made locally and revert to previously saved values.

3.1.7 SFP Information

The section describes the SFP module information which you will see when you connect an SFP module to the switch. The information includes: Connector type, Fiber type, wavelength, baud rate and Vendor OUI etc.

Web Interface

To display the SFP information in the web interface:

1. Click Configuration, Port, then SFP Information

Figure 3-1.6: The SFP Information Overview

SFP Information for Port 45	
Connector Type	SFP - LC
Fiber Type	Single Mode (SM)
Tx Central Wavelength	1310
Baud Rate	1000 Mbps
Vendor OUI	00-40-c7
Vendor Name	Ruby Tech
Vendor PN	SFP.LC.S10
Vendor Rev	
Vendor SN	7717010094
Date Code	070717
Temperature	none
Vcc	none
Mon1 (Bias)	none
Mon2 (TX PWR)	none
Mon3 (RX PWR)	none

Parameter description:

Connector Type:

Display the connector type, for instance, UTP, SC, ST, LC and so on.

Fiber Type:

Display the fiber mode, for instance, Multi-Mode, Single-Mode.

Tx Central Wavelength:

Display the fiber optical transmitting central wavelength, for instance, 850nm, 1310nm, 1550nm and so on.

Baud Rate:

Display the maximum baud rate of the fiber module supported, for instance, 10M, 100M, 1G and so on.

Vendor OUI:

Display the Manufacturer's OUI code which is assigned by IEEE.

Vendor Name:

Display the company name of the module manufacturer.

Vendor P/N:

Display the product name of the naming by module manufacturer.

Vendor Rev (Revision):

Display the module revision.

Vendor SN (Serial Number):

Show the serial number assigned by the manufacturer.

Date Code:

Show the date this SFP module was made.

Temperature:

Show the current temperature of SFP module.

Vcc:

Show the working DC voltage of SFP module.

Mon1(Bias) mA:

Show the Bias current of SFP module.

Mon2(TX PWR):

Show the transmit power of SFP module.

Mon3(RX PWR):

Show the receiver power of SFP module.

3.2 ACL

The GS-2300 series access control list (ACL) is probably the most commonly used object in the IOS. It is used for packet filtering but also for selecting types of traffic to be analyzed, forwarded, or influenced in some way. The ACLs are divided into EtherTypes, IPv4, ARP protocol, MAC and VLAN parameters etc. Here we will just go over the standard and extended access lists for TCP/IP. As you create ACEs for ingress classification, you can assign a policy for each port, the policy number is 1-8. However, each policy can be applied to any port. This makes it very easy to determine what type of ACL policy you will be working with.

3.2.1 Ports

The section describes how to configure the ACL parameters (ACE) of the each switch port. These parameters will affect frames received on a port unless the frame matches a specific ACE.

Web Interface

To configure the ACL Ports in the web interface:

1. Click Configuration, ACL, then Ports
2. To scroll the specific parameter value to select the correct value for port ACL setting.
3. Click save to save the setting
4. If you want to cancel the setting then you need to click the reset button. It will revert to previously saved values.
5. After your configuration is complete you can see the counter of the port. Then you could click refresh to update the counter or clear the information.

Figure 3-2.1: The ACL Ports Configuration

Port	Policy ID	Action	Rate Limiter ID	Port Redirect	Mirror	Logging	Shutdown	State	Counter
*		<>	<>	Disabled Port 1 Port 2	<>	<>	<>	<>	*
1	0	Permit	Disabled	Disabled Port 1 Port 2	Disabled	Disabled	Disabled	Enabled	0
2	0	Permit	Disabled	Disabled Port 1 Port 2	Disabled	Disabled	Disabled	Enabled	0

Parameter description:

Port:

The logical port for the settings contained in the same row.

Policy ID:

Select the policy to apply to this port. The allowed values are 1 through 8. The default value is 1.

Action:

Select whether forwarding is permitted ("Permit") or denied ("Deny"). The default value is "Permit".

Rate Limiter ID:

Select which rate limiter to apply on this port. The allowed values are Disabled or the values 1 through 16. The default value is "Disabled".

Port Copy:

Select which port frames are copied on. The allowed values are Disabled or a specific port number. The default value is "Disabled".

Mirror:

Specify the mirror operation of this port. The allowed values are:

Enabled: Frames received on the port are mirrored.

Disabled: Frames received on the port are not mirrored.

The default value is "Disabled".

Logging:

Specify the logging operation of this port. The allowed values are:

Enabled: Frames received on the port are stored in the System Log.

Disabled: Frames received on the port are not logged.

The default value is "Disabled". Please note that the System Log memory size and logging rate is limited.

Shutdown:

Specify the port shut down operation of this port. The allowed values are:

Enabled: If a frame is received on the port, the port will be disabled.

Disabled: Port shut down is disabled.

The default value is "Disabled".

Counter:

Counts the number of frames that match this ACE.

Buttons

Save – Click to save changes.

Reset – Click to undo any changes made locally and revert to previously saved values.

Refresh

Refresh the ACL Port Configuration manually.

Clear

Clear the ACL Port Configuration manually.

3.2.2 Rate Limiters

The section describes how to configure the switch's ACL Rate Limiter parameters. The Rate Limiter Level from 1 to 16 allows the user to set rate limiter values and units (pps or kbps).

Web Interface

To configure ACL Rate Limiter in the web interface:

1. Click Configuration, ACL, then Rate Limiter
2. Specify the Rate field and the range from 0 to 3276700.
3. Select the unit: pps or kbps.
4. Click save to save the settings.

5. If you want to cancel the setting then you need to click the reset button. It will revert to previously saved values.

Figure 3-2.2: The ACL Rate Limiter Configuration

Rate Limiter ID	Rate	Unit
1	1	pps
2	1	pps
3	1	pps
4	1	pps
5	1	pps
6	1	pps
7	1	pps
8	1	pps
9	1	pps
10	1	pps
11	1	pps
12	1	pps
13	1	pps
14	1	pps
15	1	pps
16	1	pps

Save Reset

Parameter description:

Rate Limiter ID:

The rate limiter ID for the settings contained in the same row.

Rate

The allowed values are: 0-3276700 in pps or 0, 100, 200, 300, ..., 1000000 in kbps.

Unit:

Specify the rate unit. The allowed values are:

pps: packets per second.

kbps: Kbits per second.

Buttons

Save – Click to save changes.

Reset – Click to undo any changes made locally and revert to previously saved values.

3.2.3 Access Control List

The section describes how to configure Access Control List rules. An Access Control List (ACL) is a sequential list of permit or deny conditions that apply to IP addresses, MAC addresses, or other more specific criteria. This switch tests ingress packets against the conditions in an ACL one by one. A packet will be accepted as soon as it matches a permit rule, or dropped as soon as it matches a deny rule. If no rules match, the frame is accepted. Other actions can also be invoked when a matching packet is found, including rate limiting, copying matching packets to another port or to the system log, or shutting down a port.

This page shows the Access Control List (ACL), which is made up of the ACEs defined on this switch. Each row describes the ACE that is defined. The maximum number of ACEs is 256 on each switch. Click on the lowest plus sign to add a new ACE to the list. The reserved ACEs are used for internal protocol and cannot be edited or deleted, the order sequence cannot be changed and the priority is highest

Web Interface

To configure Access Control Lists in the web interface:

1. Click Configuration, ACL, then Configuration

2. Click the  button to add a new ACL, or use the other ACL

modification buttons to specify the editing action (i.e., edit, delete, or moving the relative position of entry in the list)

3. Specify the parameters of the ACE

4. Click save to save the settings.

5. If you want to cancel the setting then you need to click the reset button. It will revert to previously saved values.

6. When editing an entry on the ACE Configuration page, note that the Items displayed depend on various selections, such as Frame Type and IP Protocol Type. Specify the relevant criteria to be matched for this rule, and set the actions to take when a rule is matched (such as Rate Limiter, Port Copy, Logging, and Shutdown).

Figure 3-2.3: The ACL Rate Limiter Configuration

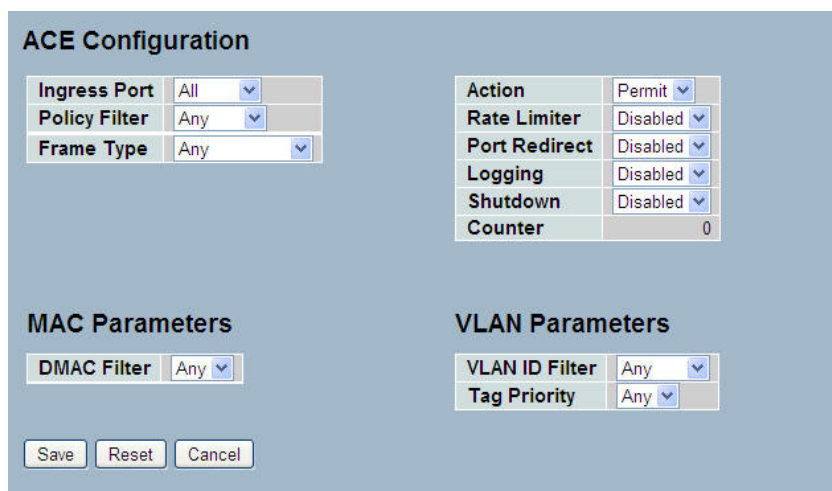
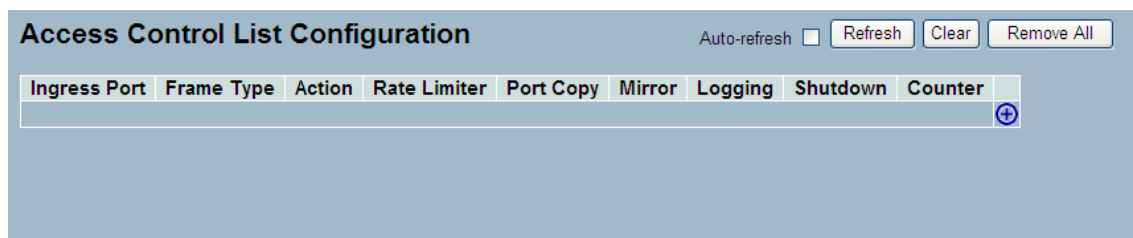

Parameter description:

Ingress Port:

Indicates the ingress port of the ACE. Possible values are:

Any: The ACE will match any ingress port.

Policy: The ACE will match ingress ports with a specific policy.

Port: The ACE will match a specific ingress port.

Frame Type:

Indicates the frame type of the ACE. Possible values are:

Any: The ACE will match any frame type.

3 Configuration

Ethernet type: The ACE will match Ethernet Type frames. Note that an Ethernet Type based ACE will not get matched by IP and ARP frames.

ARP: The ACE will match ARP/RARP frames.

IPv4: The ACE will match all IPv4 frames.

Action:

Indicates the forwarding action of the ACE.

Permit: Frames matching the ACE may be forwarded and learned.

Deny: Frames matching the ACE are dropped.

Rate Limiter:

Indicates the rate limiter number of the ACE. The allowed range is 1 to 16. When Disabled is displayed, the rate limiter operation is disabled.

Port Copy:

Indicates the port copy operation of the ACE. Frames matching the ACE are copied to the port number. The allowed values are Disabled or a specific port number. When Disabled is displayed, the port copy operation is disabled.

Mirror:

Specify the mirror operation of this port. The allowed values are:

Enabled: Frames received on the port are mirrored.

Disabled: Frames received on the port are not mirrored.

The default value is "Disabled".

Logging:

Indicates the logging operation of the ACE. Possible values are:

Enabled: Frames matching the ACE are stored in the System Log.

Disabled: Frames matching the ACE are not logged.

Please note that the System Log memory size and logging rate is limited.

Shutdown:

Indicates the port shut down operation of the ACE. Possible values are:

Enabled: If a frame matches the ACE, the ingress port will be disabled.

Disabled: Port shut down is disabled for the ACE.

Counter:

The counter indicates the number of times the ACE was hit by a frame.

Modification Buttons

You can modify each ACE (Access Control Entry) in the table using the following buttons:

- Inserts a new ACE before the current row.
- ✎ Edits the ACE row.
- ⬆ Moves the ACE up the list.
- ⬇ Moves the ACE down the list.
- ✖ Deletes the ACE.
- ➕ The lowest plus sign adds a new entry at the bottom of the ACE listings.

MAC Parameter:

SMAC Filter

(Only displayed when the frame type is Ethernet Type or ARP.)

Specify the source MAC filter for this ACE.

Any: No SMAC filter is specified. (SMAC filter status is "don't-care".)

Specific: If you want to filter a specific source MAC address with this ACE, choose this value. A field for entering an SMAC value appears.

SMAC Value

When "Specific" is selected for the SMAC filter, you can enter a specific source MAC address. The legal format is "xx-xx-xx-xx-xx-xx" or "xx.xx.xx.xx.xx.xx" or "xxxxxxxxxxx" (x is a hexadecimal digit). A frame that hits this ACE matches this SMAC value.

DMAC Filter

Specify the destination MAC filter for this ACE.

Any: No DMAC filter is specified. (DMAC filter status is "don't-care".)

MC: Frame must be multicast.

BC: Frame must be broadcast.

UC: Frame must be unicast.

Specific: If you want to filter a specific destination MAC address with this ACE, choose this value. A field for entering a DMAC value appears.

DMAC Value

When "Specific" is selected for the DMAC filter, you can enter a specific destination MAC address. The legal format is "xx-xx-xx-xx-xx-xx" or "xx.xx.xx.xx.xx.xx" or "xxxxxxxxxxx" (x is a hexadecimal digit). A frame that hits this ACE matches this DMAC value.

Buttons

Save – Click to save changes.

Reset – Click to undo any changes made locally and revert to previously saved values.

Auto-refresh:

Activate the auto-refresh to refresh the information automatically.

Refresh

Refresh the ACL configuration manually

Clear

Clear the ACL configuration.

Remove All

Remove all ACL configurations from the table.

3.2.4 ACL Status

The section describes how to show the ACL status by different ACL users. Each row describes the ACE that is defined. It is a conflict if a specific ACE is not applied to the hardware due to hardware limitations. The maximum number of ACEs is 256 on each switch.

Web Interface

To display the ACL status in the web interface:

3 Configuration

1. Click Configuration, ACL, then ACL status
2. If you want to auto-refresh the information then you need to activate "Auto-refresh".
3. Click "Refresh" to refresh the ACL Status

Figure 3-2.4: The ACL Status

ACL Status									
						Combined	<input type="checkbox"/> Auto-refresh	<input type="button" value="Refresh"/>	
User	Ingress Port	Frame Type	Action	Rate Limiter	Port Redirect	CPU	CPU Once	Counter	Conflict
IP Management	All	ARP	Permit	Disabled	Disabled	Yes	No	198	No
IP Management	All	IPv4/UDP 68 DHCP Server	Permit	Disabled	Disabled	Yes	No	0	No

Parameter description:

User:

Indicates the ACL user.

Ingress Port:

Indicates the ingress port of the ACE. Possible values are:

Any: The ACE will match any ingress port.

Policy: The ACE will match ingress ports with a specific policy.

Port: The ACE will match a specific ingress port.

Frame Type:

Indicates the frame type of the ACE. Possible values are:

Any: The ACE will match any frame type.

EType: The ACE will match Ethernet Type frames. Note that an Ethernet Type based ACE will not get matched by IP and ARP frames.

ARP: The ACE will match ARP/RARP frames.

IPv4: The ACE will match all IPv4 frames.

Action:

Indicates the forwarding action of the ACE.

Permit: Frames matching the ACE may be forwarded and learned.

Deny: Frames matching the ACE are dropped.

Rate Limiter:

Indicates the rate limiter number of the ACE. The allowed range is 1 to 16. When Disabled is displayed, the rate limiter operation is disabled.

Port Copy:

Indicates the port copy operation of the ACE. Frames matching the ACE are copied to the port number. The allowed values are Disabled or a specific port number. When Disabled is displayed, the port copy operation is disabled.

Mirror:

Specify the mirror operation of this port. The allowed values are:

Enabled: Frames received on the port are mirrored.

Disabled: Frames received on the port are not mirrored.

The default value is "Disabled".

CPU:

Forward packet that matched the specific ACE to CPU.

CPU Once:

Forward first packet that matched the specific ACE to CPU.

Counter:

The counter indicates the number of times the ACE was hit by a frame.

Conflict:

Indicates the hardware status of the specific ACE. The specific ACE is not applied to the hardware due to hardware limitations.

Auto-refresh:

Activate the auto-refresh to refresh the information automatically.

Refresh

Refresh the ACL status information manually.

3.3 Aggregation

You can bundle more than one port with the same speed, full duplex and the same MAC to be a single logical port, thus the logical port aggregates the bandwidth of these ports. This means you can apply your current Ethernet equipment's to build the bandwidth aggregation. For example, if there are three Fast Ethernet ports aggregated in a logical port, then this logical port has bandwidth three times as high as a single Fast Ethernet port has.

3.3.1 Static Trunk

The Aggregation Configuration is used to configure the settings of Link Aggregation. You can bundle more than one port with the same speed, full duplex and the same MAC to be a single logical port, thus the logical port aggregates the bandwidth of these ports. This means you can apply your current Ethernet equipment's to build the bandwidth aggregation.

3-3.1.1 Static Trunk

Ports using Static Trunk as their trunk method can choose their unique Static GroupID to form a logic "trunked port". The benefit of using Static Trunk method is that a port can immediately become a member of a trunk group without any handshaking with its peer port. This is also a disadvantage because the peer ports of your static trunk group may not know that they should be aggregate together to form a "logic trunked port". Using Static Trunk on both end of a link is strongly recommended. Please also note that low speed links will stay in "not ready" state when using static trunk to aggregate with high speed links.

Web Interface

To configure the Trunk Aggregation Hash mode and Aggregation Group in the web interface:

1. Click Configuration, Static Trunk, and then Aggregation Mode Configuration.
2. Activate to enable or disable the aggregation mode function.

Activate Aggregation Group ID and Port members

3. Click Save to save the setting
4. If you want to cancel the setting then you need to click the reset button. It will revert to previously saved values.

Figure 3-3.1.1: The Aggregation Mode Configuration

3 Configuration

Aggregation Mode Configuration

Hash Code Contributors

Source MAC Address

Destination MAC Address

IP Address

TCP/UDP Port Number

Aggregation Group Configuration

Group ID	Port Members																											
	1	2	3	4	5	6	7	8	9	10	11	12	13	14	15	16	17	18	19	20	21	22	23	24	25	26	27	28
Normal	<input type="radio"/>	<input type="radio"/>	<input type="radio"/>	<input type="radio"/>	<input type="radio"/>	<input type="radio"/>	<input type="radio"/>	<input type="radio"/>	<input type="radio"/>	<input type="radio"/>	<input type="radio"/>	<input type="radio"/>	<input type="radio"/>	<input type="radio"/>	<input type="radio"/>	<input type="radio"/>	<input type="radio"/>	<input type="radio"/>	<input type="radio"/>	<input type="radio"/>	<input type="radio"/>	<input type="radio"/>	<input type="radio"/>	<input type="radio"/>	<input type="radio"/>	<input type="radio"/>	<input type="radio"/>	<input type="radio"/>
1	<input type="radio"/>	<input type="radio"/>	<input type="radio"/>	<input type="radio"/>	<input type="radio"/>	<input type="radio"/>	<input type="radio"/>	<input type="radio"/>	<input type="radio"/>	<input type="radio"/>	<input type="radio"/>	<input type="radio"/>	<input type="radio"/>	<input type="radio"/>	<input type="radio"/>	<input type="radio"/>	<input type="radio"/>	<input type="radio"/>	<input type="radio"/>	<input type="radio"/>	<input type="radio"/>	<input type="radio"/>	<input type="radio"/>	<input type="radio"/>	<input type="radio"/>	<input type="radio"/>	<input type="radio"/>	<input type="radio"/>
2	<input type="radio"/>	<input type="radio"/>	<input type="radio"/>	<input type="radio"/>	<input type="radio"/>	<input type="radio"/>	<input type="radio"/>	<input type="radio"/>	<input type="radio"/>	<input type="radio"/>	<input type="radio"/>	<input type="radio"/>	<input type="radio"/>	<input type="radio"/>	<input type="radio"/>	<input type="radio"/>	<input type="radio"/>	<input type="radio"/>	<input type="radio"/>	<input type="radio"/>	<input type="radio"/>	<input type="radio"/>	<input type="radio"/>	<input type="radio"/>	<input type="radio"/>	<input type="radio"/>	<input type="radio"/>	<input type="radio"/>
3	<input type="radio"/>	<input type="radio"/>	<input type="radio"/>	<input type="radio"/>	<input type="radio"/>	<input type="radio"/>	<input type="radio"/>	<input type="radio"/>	<input type="radio"/>	<input type="radio"/>	<input type="radio"/>	<input type="radio"/>	<input type="radio"/>	<input type="radio"/>	<input type="radio"/>	<input type="radio"/>	<input type="radio"/>	<input type="radio"/>	<input type="radio"/>	<input type="radio"/>	<input type="radio"/>	<input type="radio"/>	<input type="radio"/>	<input type="radio"/>	<input type="radio"/>	<input type="radio"/>	<input type="radio"/>	<input type="radio"/>
24	<input type="radio"/>	<input type="radio"/>	<input type="radio"/>	<input type="radio"/>	<input type="radio"/>	<input type="radio"/>	<input type="radio"/>	<input type="radio"/>	<input type="radio"/>	<input type="radio"/>	<input type="radio"/>	<input type="radio"/>	<input type="radio"/>	<input type="radio"/>	<input type="radio"/>	<input type="radio"/>	<input type="radio"/>	<input type="radio"/>	<input type="radio"/>	<input type="radio"/>	<input type="radio"/>	<input type="radio"/>	<input type="radio"/>	<input type="radio"/>	<input type="radio"/>	<input type="radio"/>	<input type="radio"/>	<input type="radio"/>
25	<input type="radio"/>	<input type="radio"/>	<input type="radio"/>	<input type="radio"/>	<input type="radio"/>	<input type="radio"/>	<input type="radio"/>	<input type="radio"/>	<input type="radio"/>	<input type="radio"/>	<input type="radio"/>	<input type="radio"/>	<input type="radio"/>	<input type="radio"/>	<input type="radio"/>	<input type="radio"/>	<input type="radio"/>	<input type="radio"/>	<input type="radio"/>	<input type="radio"/>	<input type="radio"/>	<input type="radio"/>	<input type="radio"/>	<input type="radio"/>	<input type="radio"/>	<input type="radio"/>	<input type="radio"/>	<input type="radio"/>
26	<input type="radio"/>	<input type="radio"/>	<input type="radio"/>	<input type="radio"/>	<input type="radio"/>	<input type="radio"/>	<input type="radio"/>	<input type="radio"/>	<input type="radio"/>	<input type="radio"/>	<input type="radio"/>	<input type="radio"/>	<input type="radio"/>	<input type="radio"/>	<input type="radio"/>	<input type="radio"/>	<input type="radio"/>	<input type="radio"/>	<input type="radio"/>	<input type="radio"/>	<input type="radio"/>	<input type="radio"/>	<input type="radio"/>	<input type="radio"/>	<input type="radio"/>	<input type="radio"/>	<input type="radio"/>	<input type="radio"/>

Apply Reset

Parameter description:

Hash Code Contributors

Source MAC Address:

The Source MAC address can be used to calculate the destination port for the frame. Check to enable the use of the Source MAC address, or uncheck to disable. By default, Source MAC Address is enabled.

Destination MAC Address:

The Destination MAC Address can be used to calculate the destination port for the frame. Check to enable the use of the Destination MAC Address, or uncheck to disable. By default, Destination MAC Address is disabled.

IP Address:

The IP address can be used to calculate the destination port for the frame. Check to enable the use of the IP Address, or uncheck to disable. By default, IP Address is enabled.

TCP/UDP Port Number:

The TCP/UDP port number can be used to calculate the destination port for the frame. Check to enable the use of the TCP/UDP Port Number, or uncheck to disable. By default, TCP/UDP Port Number is enabled.

Aggregation Group Configuration

Locality:

Indicates the aggregation group type. This field is only valid for switches.

Global: The group members may reside on different units. The device supports two 8-port global aggregations.

Local: The group members reside on the same unit. Each local aggregation may consist of up to 16 members.

Group ID:

Indicates the group ID for the settings contained in the same row. Group ID "Normal" indicates there is no aggregation. Only one group ID is valid per port.

Port Members:

Each switch port is listed for each group ID. Select a radio button to include a port in an aggregation, or clear the radio button to remove the port from the aggregation. By default, no ports belong to any aggregation group. Only full duplex ports can join an aggregation and ports must be in the same speed in each group.

Buttons

Save – Click to save changes.

Reset – Click to undo any changes made locally and revert to previously saved values.

3.3.2 LACP

Ports using Link Aggregation Control Protocol (according to IEEE 802.3ad specification) as their trunking method can choose their unique LACP GroupID to form a logic “trunked port”. The benefit of using LACP is that a port makes an agreement with its peer port before it becomes a ready member of a “trunk group” (also called aggregator). LACP is safer than the other trunking method - static trunk.

3-3.2.1 Configuration

This page allows the user to inspect the current LACP port configurations, and possibly change them as well. An LACP trunk group with more than one ready member-ports is a “real trunked” group. An LACP trunk group with only one or less than one ready member-ports is not a “real trunked” group.

Web Interface

To configure the Trunk Aggregation LACP parameters in the web interface:

1. Click Configuration, LACP, Configuration
2. Activate to enable or disable the LACP on the port.
3. Select the Key parameter: Auto or specific value. Default is Auto.
4. Select the Role: Active or Passive. Default is Active.
5. Click Save to save the settings
6. If you want to cancel the setting then you need to click the reset button. It will revert to previously saved values.

Figure 3-3.2.1: The LACP Port Configuration

Port	LACP Enabled	Key	Role
-	<input type="checkbox"/>	<>	<>
1	<input type="checkbox"/>	Auto	Active
2	<input type="checkbox"/>	Auto	Active
3	<input type="checkbox"/>	Auto	Active
50	<input type="checkbox"/>	Auto	Active
51	<input type="checkbox"/>	Auto	Active
52	<input type="checkbox"/>	Auto	Active

Save Reset

Parameter description:

Port:

The switch port number.

LACP Enabled:

Controls whether LACP is enabled on this switch port. LACP will form an aggregation when 2 or more ports are connected to the same partner. LACP can form max 12 LLAGs per switch and 2 GLAGs.

Key:

The Key value incurred by the port, range 1-65535. The Auto setting will set the key as appropriate by the physical link speed, 10Mb = 1, 100Mb = 2, 1Gb = 3. Using the Specific setting, a user-defined value can be entered. Ports with the same Key value can participate in the same aggregation group, while ports with different keys cannot.

Role:

The Role shows the LACP activity status. The Active will transmit LACP packets each second, while Passive will wait for a LACP packet from a partner (speak if spoken to).

Buttons

Save – Click to save changes.

Reset – Click to undo any changes made locally and revert to previously saved values.

3-3.2.2 System Status

This section describes the LACP System Status which is provided when LACP is configured on the switch.

Web Interface

To display the LACP System status in the web interface:

1. Click Configuration, LACP, System Status
2. If you want to auto-refresh the information then you need to activate "Auto-refresh".
3. Click "Refresh" to refresh the LACP System Status.

Figure 3-3.2.2: The LACP System Status

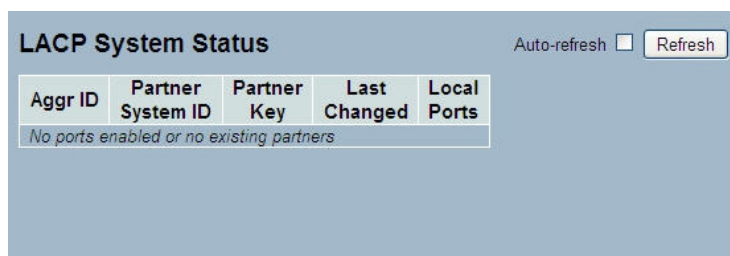

Parameter description:

Aggr ID:

The Aggregation ID associated with this aggregation instance. For LLAG the id is shown as 'isid:aggr-id' and for GLAGs as 'aggr-id'

Partner System ID:

The system ID (MAC address) of the aggregation partner.

Partner Key:

The Key that the partner has assigned to this aggregation ID.

Last changed:

The time since this aggregation changed.

Local Ports:

Shows which ports are a part of this aggregation for this switch. The format is: "Switch ID:Port".

Auto-refresh:

To activate the auto-refresh to refresh the information automatically.

Refresh

Refresh the LACP System status information manually.

3-3.2.3 Port Status

This section describes the LACP Status which is provided when LACP is configured on the switch.

Web Interface

To display the LACP Port status in the web interface:

1. Click Configuration, LACP, Port Status
2. If you want to auto-refresh the information then you need to activate "Auto-refresh".
3. Click "Refresh" to refresh the LACP Port Status.

Figure 3-3.2.3: The LACP Status

Port	LACP	Key	Aggr ID	Partner System ID	Partner Port
1	No	-	-	-	-
2	No	-	-	-	-
3	No	-	-	-	-
4	No	-	-	-	-

Parameter description:

Port:

The switch port number.

LACP:

'Yes' means that LACP is enabled and the port link is up. 'No' means that LACP is not enabled or that the port link is down. 'Backup' means that the port could not join the aggregation group but will join if other port leaves. Meanwhile its LACP status is disabled.

Key:

The key assigned to this port. Only ports with the same key can aggregate together.

Aggr ID:

The Aggregation ID assigned to this aggregation group. IDs 1 and 2 are GLAGs while IDs 3-14 are LLAGs.

Partner System ID:

The partner's System ID (MAC address).

Partner Port:

The partner's port number connected to this port.

Auto-refresh:

To activate the auto-refresh to refresh the information automatically.

Refresh:

Refresh the LACP port status information manually.

3-3.2.4 Port Statistics

This section describes the LACP Statistics which are provided when LACP is configured on the switch.

Web Interface

To display the LACP Port statistics in the web interface:

1. Click Configuration, LACP, Port Statistics
2. If you want to auto-refresh the information then you need to activate "Auto refresh".
3. Click "Refresh" to refresh the LACP Statistics.

Figure 3-3.2.4: The LACP Statistics

Port	LACP Received	LACP Transmitted	Discarded	
			Unknown	Illegal
1	0	0	0	0
2	0	0	0	0
3	0	0	0	0
4	0	0	0	0
5	0	0	0	0

3 Configuration

Parameter description:

Port:

The switch port number.

LACP Received:

Shows how many LACP frames have been received at each port.

LACP Transmitted:

Shows how many LACP frames have been sent from each port.

Discarded:

Shows how many unknown or illegal LACP frames have been discarded at each port.

Auto-refresh:

To activate the auto-refresh to refresh the information automatically.

Refresh:

Refresh the LACP port statistics information manually.

Clear:

Clear the LACP port statistics information manually.

3.4 Spanning Tree

The Spanning Tree Protocol (STP) can be used to detect and disable network loops, and to provide backup links between switches, bridges or routers. This allows the switch to interact with other bridging devices (that is, an STP-compliant switch, bridge or router) in your network to ensure that only one route exists between any two stations on the network, and provide backup links which automatically take over when a primary link goes down.

STP - STP uses a distributed algorithm to select a bridging device (STP-compliant switch, bridge or router) that serves as the root of the spanning tree network. It selects a root port on each bridging device (except for the root device) which incurs the lowest path cost when forwarding a packet from that device to the root device. Then it selects a designated bridging device from each LAN which incurs the lowest path cost when forwarding a packet from that LAN to the root device. All ports connected to designated bridging devices are assigned as designated ports. After determining the lowest cost spanning tree, it enables all root ports and designated ports, and disables all other ports. Network packets are therefore only forwarded between root ports and designated ports, eliminating any possible network loops.

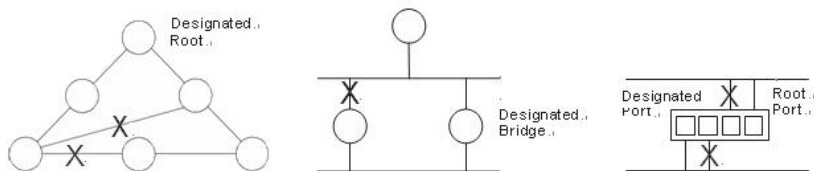

Once a stable network topology has been established, all bridges listen for Hello BPDUs (Bridge Protocol Data Units) transmitted from the Root Bridge. If a bridge does not get a Hello BPDU after a predefined interval (Maximum Age), the bridge assumes that the link to the Root Bridge is down. This bridge will then initiate negotiations with other bridges to reconfigure the network to reestablish a valid network topology.

3.4.1 Bridge Settings

The section describes how to configure the Spanning Tree Bridge and STP System settings. It allows you to configure STP System settings which are used by all STP Bridge instances in the Switch.

Web Interface

To configure the Spanning Tree Bridge Settings parameters in the web interface:

1. Click Configuration, Spanning Tree, Bridge Settings
2. Select the parameters and enter available values of parameters in the blank field in Basic Settings
3. Activate to enable or disable the parameters and enter available value of parameters in the blank field in Advanced settings
4. Click Save to save the setting
5. If you want to cancel the setting then you need to click the Reset button. It will revert to previously saved values

Figure 3-4.1: The STP Bridge Configuration

STP Bridge Configuration

Basic Settings

Protocol Version	MSTP
Bridge Priority	128
Forward Delay	15
Max Age	20
Maximum Hop Count	20
Transmit Hold Count	6

Advanced Settings

Edge Port BPDU Filtering	<input type="checkbox"/>
Edge Port BPDU Guard	<input type="checkbox"/>
Port Error Recovery	<input type="checkbox"/>
Port Error Recovery Timeout	<input type="text"/>

Save Reset

Parameter description:

Basic Settings

Protocol Version:

The STP protocol version setting. Valid values are STP, RSTP and MSTP.

Bridge Priority:

Controls the bridge priority. Lower numeric values have better priority. The bridge priority plus the MSTI instance number, concatenated with the 6-byte MAC address of the switch forms a Bridge Identifier. For MSTP operation, this is the priority of the CIST. Otherwise, this is the priority of the STP/RSTP bridge.

Forward Delay:

The delay used by STP Bridges to transit Root and Designated Ports to Forwarding (used in STP compatible mode). Valid values are in the range 4 to 30 seconds.

Max Age:

The maximum age of the information transmitted by the Bridge when it is the Root Bridge. Valid values are in the range 6 to 40 seconds, and MaxAge must be $\leq (\text{FwdDelay}-1)*2$.

Maximum Hop Count:

This defines the initial value of remaining Hops for MSTI information generated at the boundary of an MSTI region. It defines how many bridges a root bridge can distribute its BPDU information to. Valid values are in the range 6 to 40 hops.

Transmit Hold Count:

The number of BPDU's a bridge port can send per second. When exceeded, transmission of the next BPDU will be delayed. Valid values are in the range 1 to 10 BPDU's per second.

Advanced Settings

Edge Port BPDU Filtering:

Control whether a port explicitly configured as Edge will transmit and receive BPDUs.

Edge Port BPDU Guard:

Control whether a port explicitly configured as Edge will disable itself upon reception of a BPDU. The port will enter the error-disabled state, and will be removed from the active topology.

Port Error Recovery:

Control whether a port in the error-disabled state automatically will be enabled after a certain time. If recovery is not enabled, ports have to be disabled and re-enabled for normal STP operation. The condition is also cleared by a system reboot.

Port Error Recovery Timeout:

The time to pass before a port in the error-disabled state can be enabled. Valid values are between 30 and 86400 seconds (24 hours).

Buttons

Save – Click to save changes.

Reset – Click to undo any changes made locally and revert to previously saved values.

3.4.2 MSTI Mapping

When you implement a Spanning Tree protocol on the switch that the bridge instance the CIST is not available for explicit mapping, as it will receive the VLANs not explicitly mapped. Due to the reason that you need to set the list of VLANs mapped to the MSTI. The VLANs must be separated with comma and/or space. A VLAN can only be mapped to one MSTI. An unused MSTI should just be left empty. (I.e. not having any VLANs mapped to it.)

This section describes how the user can inspect the current STP MSTI bridge instance priority configurations, and possibly change them as well.

Web Interface

To configure the Spanning Tree MSTI Mapping parameters in the web interface:

1. Click Configuration, Spanning Tree, MSTI Mapping
2. Specify the configuration identification parameters in the field
3. Specify the VLANs Mapped blank field.
4. Click Save to save the setting
5. If you want to cancel the setting then you need to click the Reset button. It will revert to previously saved values

Figure 3-4.2: The MSTI Configuration

MSTI Configuration

Add VLANs separated by spaces or comma.
Unmapped VLANs are mapped to the CIST. (The default bridge instance).

Configuration Identification

Configuration Name	00-40-c7-74-00-d1
Configuration Revision	0

MSTI Mapping

MSTI	VLANs Mapped
MSTI1	
MSTI2	
MSTI3	
MSTI4	
MSTI5	
MSTI6	
MSTI7	

Parameter description:

Configuration Identification

Configuration Name:

The name identifying the VLAN to MSTI mapping. Bridges must share the name and revision (see below), as well as the VLAN-to-MSTI mapping configuration in order to share spanning trees for MSTI's (Intra-region). The name is at most 32 characters.

Configuration Revision:

The revision of the MSTI configuration named above. This must be an integer between 0 and 65535.

MSTI Mapping

MSTI:

The bridge instance. The CIST is not available for explicit mapping, as it will receive the VLANs not explicitly mapped.

VLANs Mapped:

The list of VLANs mapped to the MSTI. The VLANs must be separated with comma and/or space. A VLAN can only be mapped to one MSTI. An unused MSTI should just be left empty. (I.e. not having any VLANs)

Buttons

Save – Click to save changes.

Reset – Click to undo any changes made locally and revert to previously saved values.

3.4.3 MSTI Priorities

When you implement a Spanning Tree protocol on the switch that the bridge instance. The CIST is the default instance which is always active. For controls the bridge priority. Lower numeric values have better priority. The bridge priority plus the MSTI instance number, concatenated with the 6-byte MAC address of the switch forms a Bridge Identifier

This section show how the user can inspect the current STP MSTI bridge instance priority configurations, and possibly change them as well.

Web Interface

To configure the Spanning Tree MSTI Priorities parameters in the web interface:

1. Click Configuration, Spanning Tree, MSTI Priorities
2. Scroll the Priority maximum is 240. Default is 128.
3. Click "Save" to save the settings.
4. If you want to cancel the setting then you need to click the Reset button. It will revert to previously saved values

Figure 3-4.3: The MSTI Configuration

MSTI	Priority
CIST	128
MSTI1	128
MSTI2	128
MSTI3	128
MSTI4	128
MSTI5	128
MSTI6	128
MSTI7	128

Save Reset

Parameter description:

MSTI:

The bridge instance. The CIST is the default instance, which is always active.

Priority:

Controls the bridge priority. Lower numeric values have better priority. The bridge priority plus the MSTI instance number, concatenated with the 6-byte MAC address of the switch forms a Bridge Identifier.

Buttons

Save – Click to save changes.

Reset – Click to undo any changes made locally and revert to previously saved values.

3.4.4 CIST Ports

When you implement a Spanning Tree protocol on the switch that the bridge instance. You need to configure the CIST Ports. The section describes how the user to inspect to inspect the current STP CIST port configurations, and possibly change them as well.

Web Interface

To configure the Spanning Tree CIST Ports parameters in the web interface:

1. Click Configuration, Spanning Tree, CIST Ports
2. Set the parameters of the CIST Aggregated Port Configuration.
3. Enable or disable the STP, then set the parameters of the CIST normal Port configuration.

4. Click Save to save the settings.

5. If you want to cancel the settings then you need to click the Reset button. It will revert to previously saved values.

Figure 3-4.4: The STP CIST Port Configuration

STP CIST Port Configuration

CIST Aggregated Port Configuration

Port	STP Enabled	Path Cost	Priority	Admin Edge	Auto Edge	Restricted Role	TCN	BPDU Guard	Point-to-point
-	<input type="checkbox"/>	Auto	128	Non-Edge	<input checked="" type="checkbox"/>	<input type="checkbox"/>	<input type="checkbox"/>	<input type="checkbox"/>	Forced True

CIST Normal Port Configuration

Port	STP Enabled	Path Cost	Priority	Admin Edge	Auto Edge	Restricted Role	TCN	BPDU Guard	Point-to-point
*	<input type="checkbox"/>	<>	<>	<>	<input checked="" type="checkbox"/>	<input type="checkbox"/>	<input type="checkbox"/>	<input type="checkbox"/>	<>
1	<input type="checkbox"/>	Auto	128	Non-Edge	<input checked="" type="checkbox"/>	<input type="checkbox"/>	<input type="checkbox"/>	<input type="checkbox"/>	Auto
2	<input type="checkbox"/>	Auto	128	Non-Edge	<input checked="" type="checkbox"/>	<input type="checkbox"/>	<input type="checkbox"/>	<input type="checkbox"/>	Auto
3	<input type="checkbox"/>	Auto	128	Non-Edge	<input checked="" type="checkbox"/>	<input type="checkbox"/>	<input type="checkbox"/>	<input type="checkbox"/>	Auto
4	<input type="checkbox"/>	Auto	128	Non-Edge	<input checked="" type="checkbox"/>	<input type="checkbox"/>	<input type="checkbox"/>	<input type="checkbox"/>	Auto
49	<input type="checkbox"/>	Auto	128	Non-Edge	<input checked="" type="checkbox"/>	<input type="checkbox"/>	<input type="checkbox"/>	<input type="checkbox"/>	Auto
50	<input type="checkbox"/>	Auto	128	Non-Edge	<input checked="" type="checkbox"/>	<input type="checkbox"/>	<input type="checkbox"/>	<input type="checkbox"/>	Auto
51	<input type="checkbox"/>	Auto	128	Non-Edge	<input checked="" type="checkbox"/>	<input type="checkbox"/>	<input type="checkbox"/>	<input type="checkbox"/>	Auto
52	<input type="checkbox"/>	Auto	128	Non-Edge	<input checked="" type="checkbox"/>	<input type="checkbox"/>	<input type="checkbox"/>	<input type="checkbox"/>	Auto

Save Reset

Parameter description:

Port:

The switch port number of the logical STP port.

STP Enabled:

Controls whether STP is enabled on this switch port.

Path Cost:

Controls the path cost incurred by the port. The Auto setting will set the path cost as appropriate by the physical link speed, using the 802.1D recommended values. Using the Specific setting, a user-defined value can be entered. The path cost is used when establishing the active topology of the network. Lower path cost ports are chosen as forwarding ports in favor of higher path cost ports. Valid values are in the range 1 to 200000000.

Priority:

Controls the port priority. This can be used to control priority of ports having identical port cost. (See above).

operEdge (state flag):

Operational flag describing whether the port is connecting directly to edge devices. (No Bridges attached). Transition to the forwarding state is faster for edge ports (having operEdge true) than for other ports. The value of this flag is based on AdminEdge and AutoEdge fields. This flag is displayed as Edge in Monitor->Spanning Tree -> STP Detailed Bridge Status.

AdminEdge:

Controls whether the operEdge flag should start as set or cleared. (The initial operEdge state when a port is initialized).

AutoEdge:

Controls whether the bridge should enable automatic edge detection on the bridge port. This allows operEdge to be derived from whether BPDU's are received on the port or not.

Restricted Role:

3 Configuration

If enabled, causes the port not to be selected as Root Port for the CIST or any MSTI, even if it has the best spanning tree priority vector. Such a port will be selected as an Alternate Port after the Root Port has been selected. If set, it can cause lack of spanning tree connectivity. It can be set by a network administrator to prevent bridges external to a core region of the network influence the spanning tree active topology, possibly because those bridges are not under the full control of the administrator. This feature is also known as Root Guard.

Restricted TCN:

If enabled, causes the port not to propagate received topology change notifications and topology changes to other ports. If set it can cause temporary loss of connectivity after changes in a spanning tree's active topology as a result of persistently incorrect learned station location information. It is set by a network administrator to prevent bridges external to a core region of the network, causing address flushing in that region, possibly because those bridges are not under the full control of the administrator or the physical link state of the attached LANs transits frequently.

BPDU Guard:

If enabled, causes the port to disable itself upon receiving valid BPDU's. Contrary to the similar bridge setting, the port Edge status does not affect this setting. A port entering error-disabled state due to this setting is subject to the bridge Port Error Recovery setting as well.

Point to Point

Controls whether the port connects to a point-to-point LAN rather than to a shared medium. This can be automatically determined, or forced either true or false. Transition to the forwarding state is faster for point-to-point LANs than for shared media.

Buttons

Save – Click to save changes.

Reset – Click to undo any changes made locally and revert to previously saved values.

3.4.5 MSTI Ports

The section describes how to view and change the current STP MSTI port configurations.

An MSTI port is a virtual port, which is instantiated separately for each active CIST (physical) port for each MSTI instance configured on and applicable to the port. The MSTI instance must be selected before displaying actual MSTI port configuration options. It contains MSTI port settings for physical and aggregated ports.

Web Interface

To configure the Spanning Tree MSTI Port Configuration parameters in the web interface:

1. Click Configuration, Spanning Tree, MSTI Ports
2. Select the MST1 or other MSTI Port
3. Click Get to set the detail parameters of the MSTI Ports.
4. Set all parameters of the MSTI Port configuration.
5. Click Save to save the setting
6. If you want to cancel the setting then you need to click the Reset button. It will revert to previously saved values

Figure 3-4.5: The MSTI Port Configuration



Parameter description:

Port:

The switch port number of the corresponding STP CIST (and MSTI) port.

Path Cost:

Controls the path cost incurred by the port. The Auto setting will set the path cost as appropriate by the physical link speed, using the 802.1D recommended values. Using the Specific setting, a user-defined value can be entered. The path cost is used when establishing the active topology of the network. Lower path cost ports are chosen as forwarding ports in favor of higher path cost ports. Valid values are in the range 1 to 200000000.

Priority:

Controls the port priority. This can be used to control priority of ports having identical port cost. (See above).

Buttons

Save – Click to save changes.

Reset – Click to undo any changes made locally and revert to previously saved values.

3.4.6 Bridge Status

After you complete the MSTI Port configuration the you could to ask the switch display the Bridge Status. The section provides a status overview of all STP bridge instances. The displayed table contains a row for each STP bridge instance, where the column displays the following information:

Web Interface

To display the STP Bridges status in the web interface:

1. Click Configuration, Spanning Tree, STP Bridges
2. If you want to auto-refresh the information then you need to activate "Auto-refresh".
3. Click "Refresh" to refresh the STP Bridges.

Figure 3-4.6: The STP Bridges status

MSTI	Bridge ID	Root			Topology Flag	Topology Change Last
		ID	Port	Cost		
CIST	80-00-00:40:C7:74:00:C9	80-00-00:40:C7:74:00:C9	-	0	Steady	-

Parameter description:

MSTI:

The Bridge Instance. This is also a link to the STP Detailed Bridge Status.

3 Configuration

Bridge ID:

The Bridge ID of this Bridge instance.

Root ID:

The Bridge ID of the currently elected root bridge.

Root Port:

The switch port currently assigned the root port role.

Root Cost:

Root Path Cost. For the Root Bridge it is zero. For all other Bridges, it is the sum of the Port Path Costs on the least cost path to the Root Bridge.

Topology Flag:

The current state of the Topology Change Flag of this Bridge instance.

Topology Change Last:

The time since last Topology Change occurred.

Auto-refresh:

Activate the auto-refresh to refresh the information automatically.

Refresh:

Refresh the STP Bridges status information manually.

3.4.7 Port Status

After you complete the STP configuration you could ask the switch to display the STP Port Status. It displays the STP CIST port status for physical ports of the currently selected switch.

Web Interface

To display the STP Port status in the web interface:

1. Click Configuration, Spanning Tree, STP Port Status
2. If you want to auto-refresh the information then you need to activate "Auto-refresh".
3. Click "Refresh" to refresh the STP Bridges.

Figure 3-4.7: The STP Port status



Port	CIST Role	CIST State	Uptime
1	Non-STP	Forwarding	-
2	Non-STP	Forwarding	-
3	Non-STP	Forwarding	-
4	Non-STP	Forwarding	-

Parameter description:

Port:

The switch port number of the logical STP port.

CIST Role:

The current STP port role of the CIST port. The port role can be one of the following values: AlternatePort, Backup Port, RootPort, DesignatedPort Disabled.

CIST State:

The current STP port state of the CIST port. The port state can be one of the following values: Blocking Learning Forwarding.

Uptime

The time since the bridge port was last initialized.

Auto-refresh:

Activate the auto-refresh to refresh the information automatically.

Refresh

Refresh the STP Port status information manually.

3.4.8 Port Statistics

After you complete the STP configuration then you could to let the switch display the STP Statistics. The Section provides you to ask switch to display the STP Statistics detail counters of bridge ports in the currently selected switch.

Web Interface

To display the STP Port status in the web interface:

1. Click Configuration, Spanning Tree, Port Statistics
2. If you want to auto-refresh the information then you need to activate "Auto-refresh".
3. Click "Refresh" to refresh the STP Bridges.

Figure 3-4.8: The STP Statistics

Port	Transmitted				Received				Discarded	
	MSTP	RSTP	STP	TCN	MSTP	RSTP	STP	TCN	Unknown	Illegal
<i>No ports enabled</i>										

Parameter description:

Port:

The switch port number of the logical STP port.

MSTP:

The number of MSTP Configuration BPDU's received/transmitted on the port.

RSTP:

The number of RSTP Configuration BPDU's received/transmitted on the port.

STP:

The number of legacy STP Configuration BPDU's received/transmitted on the port.

TCN:

The number of (legacy) Topology Change Notification BPDU's received/transmitted on the port.

Discarded Unknown:

The number of unknown Spanning Tree BPDU's received (and discarded) on the port.

Discarded Illegal:

The number of illegal Spanning Tree BPDU's received (and discarded) on the port.

Auto-refresh:

Activate the auto-refresh to refresh the information automatically.

Refresh

Refresh the STP Statistics information manually.

Clear

Clear the STP Statistics information manually.

3.5 IGMP Snooping

IGMP Snooping is used to establish the multicast groups to forward the multicast packet to the member ports, and, in nature, avoids wasting the bandwidth while IP multicast packets are running over the network. This is because a switch that does not support IGMP or IGMP Snooping can not tell the multicast packet from the broadcast packet, so it can only treat them all as the broadcast packet. Without IGMP Snooping, the multicast packet forwarding function is plain and nothing is different from broadcast packet.

A switch which supports IGMP Snooping with the functions of query, report and leave, a type of packet exchanged between IP Multicast Router/Switch and IP Multicast Host, can update the information of the Multicast table when a member (port) joins or leaves an IP Multicast Destination Address. With this function, once a switch receives an IP multicast packet, it will forward the packet to the members who joined in a specified IP multicast group before.

The packets will be discarded by the IGMP Snooping if the user transmits multicast packets to the multicast group that had not been built up in advance. IGMP mode enables the switch to issue IGMP function that you enable IGMP proxy or snooping on the switch, which connects to a router closer to the root of the tree. This interface is the upstream interface. The router on the upstream interface should be running IGMP.

3.5.1 Basic Configuration

The section describes how to set the basic IGMP snooping on the switch, which connects to a router closer to the root of the tree. This interface is the upstream interface. The router on the upstream interface should be running IGMP.

Web Interface

To configure the IGMP Snooping parameters in the web interface:

1. Click Configuration, IGMP Snooping, Basic Configuration
2. Activate to select enable or disable which Global configuration
3. Activate which port wants to become a Router Port or enable/ disable the Fast Leave function.
4. Set the Throttling parameter.
5. Click Save to save the setting
6. If you want to cancel the setting then you need to click the Reset button. It will revert to previously saved values.

Figure 3-5.1: The IGMP Snooping Configuration.

IGMP Snooping Configuration

Global Configuration	
Snooping Enabled	<input type="checkbox"/>
Unregistered IPMCv4 Flooding Enabled	<input checked="" type="checkbox"/>
IGMP SSM Range	232.0.0.0 / 8
Proxy Enabled	<input type="checkbox"/>

Port Related Configuration

Port	Router Port	Fast Leave	Throttling
*	<input type="checkbox"/>	<input type="checkbox"/>	<>
1	<input type="checkbox"/>	<input type="checkbox"/>	unlimited
2	<input type="checkbox"/>	<input type="checkbox"/>	unlimited
3	<input type="checkbox"/>	<input type="checkbox"/>	unlimited
4	<input type="checkbox"/>	<input type="checkbox"/>	unlimited
50	<input type="checkbox"/>	<input type="checkbox"/>	unlimited
51	<input type="checkbox"/>	<input type="checkbox"/>	unlimited
52	<input type="checkbox"/>	<input type="checkbox"/>	unlimited

Apply Reset

Parameter description:

Snooping Enabled:

Enable the Global IGMP Snooping.

Unregistered IPMCv4 Flooding enabled:

Enable unregistered IPMCv4 traffic flooding.

IGMP SSM Range:

SSM (Source-Specific Multicast) Range allows the SSM-aware hosts and routers run the SSM service model for the groups in the address range. Format: (IP address/ sub mask)

Proxy Enabled:

Enable IGMP Proxy. This feature can be used to avoid forwarding unnecessary join and leave messages to the router side.

Port:

It shows the physical Port index of switch.

Router Port:

Specify which ports act as router ports. A router port is a port on the Ethernet switch that leads towards the Layer 3 multicast device or IGMP querier.

If an aggregation member port is selected as a router port, the whole aggregation will act as a router port.

Fast Leave:

Enable the fast leave on the port.

Throttling:

Enable to limit the number of multicast groups to which a switch port can belong.

Buttons

Save – Click to save changes.

Reset – Click to undo any changes made locally and revert to previously saved values.

3.5.2 VLAN Configuration

The section describes the VLAN configuration setting process integrated with IGMP Snooping function. For each setting page shows up to 99 entries from the VLAN table, default being 20, selected through the "entries per page" input field. When first visited, the web page will show the first 20 entries from the beginning of the VLAN Table. The first displayed will be the one with the lowest VLAN ID found in the VLAN Table. The "VLAN" input fields allow the user to select the starting point in the VLAN Table. Clicking the button will update the displayed table starting from that or the next closest VLAN Table match.

Web Interface

To configure the IGMP Snooping VLAN in the web interface:

1. Click Configuration, IGMP Snooping, VLAN Configuration
2. Activate to select enable or disable Snooping, IGMP Querier
3. Specify the parameters in the blank field.
4. Click the refresh to update the data or click << or >> to display previous entry or next entry.
5. Click Save to save the setting
6. If you want to cancel the setting then you need to click the Reset button. It will revert to previously saved values

Figure 3-5.2: The IGMP Snooping VLAN Configuration.

VLAN ID	Snooping Enabled	IGMP Querier	Compatibility	RV	QI (sec)	QRI (0.1 sec)	LLQI (0.1 sec)	URI (sec)
1	<input type="checkbox"/>	<input checked="" type="checkbox"/>	-	-	-	-	-	-

Parameter description:

VLAN ID:

It displays the VLAN ID of the entry.

Snooping Enabled:

Enable the per-VLAN IGMP Snooping. Only up to 32 VLANs can be selected.

IGMP Querier:

A router sends IGMP Query messages onto a particular link. This Router is called the Querier. Enable the IGMP Querier in the VLAN.

Compatibility:

Compatibility is maintained by hosts and routers taking appropriate actions depending on the versions of IGMP operating on hosts and routers within a network. The allowed selection is IGMP-Auto, Forced IGMPv1, Forced IGMPv2, Forced IGMPv3, default compatibility value is IGMP-Auto.

Rv:

Robustness Variable. The Robustness Variable allows tuning for the expected packet loss on a network. The allowed range is 1 to 255; default robustness variable value is 2.

QI:

Query Interval. The Query Interval is the interval between General Queries sent by the Querier. The allowed range is 1 to 31744 seconds; default query interval is 125 seconds.

QRI:

Query Response Interval. The Max Response Time used to calculate the Max Resp Code inserted into the periodic General Queries. The allowed range is 0 to 31744 in tenths of seconds; default query response interval is 100 in tenths of seconds (10 seconds).

LLQI (LMQI for IGMP):

Last Member Query Interval. The Last Member Query Time is the time value represented by the Last Member Query Interval, multiplied by the Last Member Query Count. The allowed range is 0 to 31744 in tenths of seconds; default last member query interval is 10 in tenths of seconds (1 second).

URI:

Unsolicited Report Interval. The Unsolicited Report Interval is the time between repetitions of a host's initial report of membership in a group. The allowed range is 0 to 31744 seconds, default unsolicited report interval is 1 second.

Buttons:

Save – Click to save changes.

Reset – Click to undo any changes made locally and revert to previously saved values.

Refresh, |<<, >>:

You can click "Refresh" to refresh the displayed table starting from the "VLAN" input fields. Or click "|<<" to update the table starting from the first entry in the VLAN table, i.e. the entry with the lowest VLAN ID or click ">>" to update the table, starting with the entry after the last entry currently displayed.

3.5.3 Port Group Filtering

The section describes how to set the IGMP Port Group Filtering. In some network Application environments, like metropolitan or multiple-dwelling unit (MDU) installations, a user might want to control the multicast groups to which a user on a switch port can belong. It allows the user to control the distribution of multicast services, such as IP-TV, based on some type of subscription or service plan.

With this feature, you can filter multicast joins on a per-port basis by configuring IP multicast profiles and associating them with individual switch ports. An IGMP profile can contain one or more multicast groups and specifies whether access to the group is permitted or denied. If an IGMP profile denying access to a multicast group is applied to a switch port, the IGMP join report requesting the stream of IP multicast traffic is dropped, and the port is not allowed to receive IP multicast traffic from that group. If the filtering action permits access to the multicast group, the IGMP report from the port is forwarded for normal processing.

IGMP filtering controls only IGMP membership join reports and has no relationship to the function that directs the forwarding of IP multicast traffic.

Web Interface

To configure the IGMP Snooping Port Group in the web interface:

1. Click Configuration, IGMP Snooping, Port Group Filtering
2. Click Add new Filtering Group
3. Set the Port to enable the Port Group Filtering.
4. Specify the Filtering Groups in the blank field.
5. Click Save to save the setting
6. If you want to cancel the setting then you need to click the Reset button. It will revert to previously saved values

Figure 3-5.3: The IGMP Snooping Port Group Filtering Configuration.

IGMP Snooping Port Group Filtering Configuration

Delete Port Filtering Groups

Add new Filtering Group

Save Reset

IGMP Snooping Port Group Filtering Configuration

Delete	Port	Filtering Groups
Delete	14	224
Delete	11	239
Delete	1	

Add new Filtering Group

Save Reset

Parameter description:

Delete:

Check to delete the entry. It will be deleted during the next save.

Port:

To activate the port enable the IGMP Snooping Port Group Filtering function.

Filtering Groups:

The IP Multicast Group that will be filtered.

Buttons:

Save – Click to save changes.

Reset – Click to undo any changes made locally and revert to previously saved values.

3.5.4 Status

After you complete the IGMP Snooping configuration, you can display the IGMP Snooping Status.

Web Interface

To display the IGMP Snooping status in the web interface:

1. Click Configuration, IGMP Snooping, Status
2. If you want to auto-refresh the information then you need to activate "Auto-refresh".
3. Click "Refresh" to refresh the IGMP Snooping Status.
4. Click "Clear" to clear the IGMP Snooping Status.

Figure 3-5.4: The IGMP Snooping Status.

IGMP Snooping Status									
Auto-refresh <input type="checkbox"/> <input type="button" value="Refresh"/> <input type="button" value="Clear"/>									
Statistics									
VLAN ID	Querier Version	Host Version	Querier Status	Queries Transmitted	Queries Received	V1 Reports Received	V2 Reports Received	V3 Reports Received	V2 Leaves Received
Router Port									
Port	Status								
1	-								
2	-								
3	-								
4	-								

Parameter description:

VLAN ID:

The VLAN ID of the entry.

Querier Version:

Working Querier Version currently.

Host Version:

Working Host Version currently.

Querier Status:

Shows the Querier status is "ACTIVE" or "IDLE".

Queries Transmitted:

The number of Transmitted Queries.

Queries Received:

The number of Received Queries.

V1 Reports Received:

The number of Received V1 Reports.

V2 Reports Received:

The number of Received V2 Reports.

V3 Reports Received:

The number of Received V3 Reports.

V2 Leaves Received:

The number of Received V2 Leaves.

Auto-refresh:

Activate auto-refresh to refresh the log automatically.

Refresh:

Refresh the Status manually.

Clear:

Clear the Status manually.

3.5.5 Group Information

After completing the IGMP Snooping function you can display the IGMP Snooping Group Information. Entries in the IGMP Group Table are shown on this page. The IGMP Group Table is sorted first by VLAN ID, and then by group. It will use the last entry of the currently displayed table as a basis for the next lookup. When the end is reached the text "No more entries" is shown in the displayed table.

Web Interface

To display the IGMP Snooping Group Information in the web interface:

1. Click Configuration, IGMP Snooping, Group Information
2. If you want to auto-refresh the information then you need to activate "Auto-refresh".
3. Click "Refresh" to refresh an entry of the IGMP Snooping Groups Information.
4. Click "<< or >>" to move to previous or next entry.

Figure 3-5.5: The IGMP Snooping Groups Information.

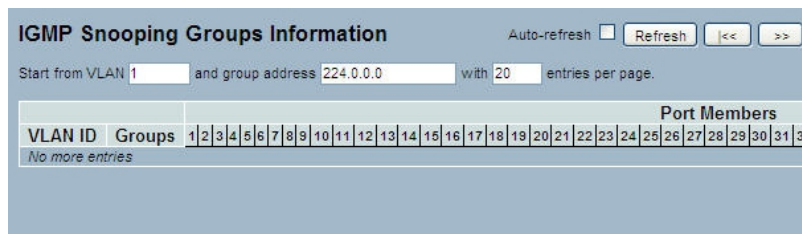

Parameter description:

Navigating the IGMP Group Table

The "Start from VLAN", and "group" input fields allow the user to select the starting point in the IGMP Group Table. The will use the last entry of the currently displayed table as a basis for the next lookup. When the end is reached the text "No more entries" is shown in the displayed table.

IGMP Group Table Columns

VLAN ID:

VLAN ID of the group.

Groups:

Group address of the group displayed.

Port Members:

Ports under this group.

Auto-refresh:

Activate the auto-refresh to refresh the log automatically.

Refresh:

Refresh the IGMP Group Status manually.

<<, >>

Go to the previous/next page or entry.

3.5.6 IPv4 SSM information

Source Specific Multicast (SSM) is a datagram delivery model that best supports one-to-many applications, also known as broadcast applications. SSM is a core network technology of IP multicast targeted for audio and video broadcast application environments.

For the SSM delivery mode, an IP multicast receiver host must use IGMP Version 3 (IGMPv3) to subscribe to channel (S, G). By subscribing to this channel, the receiver host is indicating that it wants to receive IP multicast traffic sent by source host S to group G. The network will deliver IP multicast packets from source host S to group G to all hosts in the network that have subscribed to the channel (S, G).

SSM does not require group address allocation within the network, only within each source host. Different applications running on the same source host must use different SSM groups. Different applications running on different source hosts can arbitrarily reuse SSM group addresses without causing any excess traffic on the network.

Addresses in the range 232.0.0.0/8 (232.0.0.0 to 232.255.255.255) are reserved for SSM by IANA. In the switch, you can configure SSM for arbitrary IP multicast addresses also.

Web Interface

To display the IGMPv3 IPv4 SSM Information in the web interface:

1. Click Configuration, IGMP Snooping, IPv4 SSM Information
2. If you want to auto-refresh the information then you need to activate "Auto-refresh".
3. Click "Refresh" to refresh an entry of the IGMPv3 IPv4 SSM Information.
4. Click "<< or >>" to move to previous or next entry.

Figure 3-6.6: The IGMPv3 IPv4 SSM Information.

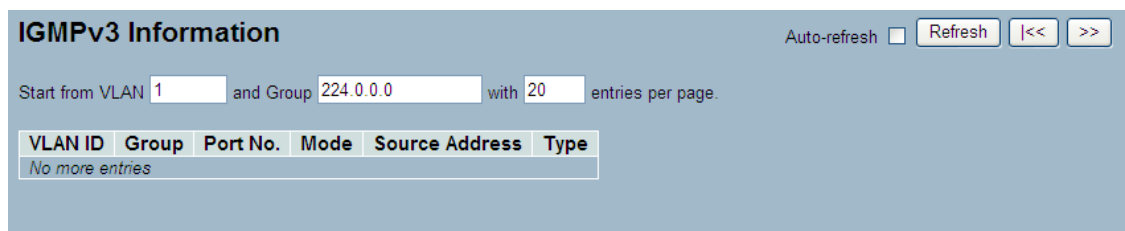

Parameter description:

Navigating the IGMPv3 Information Table

Each page shows up to 99 entries from the IGMPv3 SSM (Source Specific Multicast) Information table, default being 20, selected through the "entries per page" input field. When first visited, the web page will show the first 20 entries from the beginning of the IGMPv3 Information Table.

The "Start from VLAN", and "group" input fields allow the user to select the starting point in the IGMPv3 Information Table. Clicking the button will update the displayed table starting from that or the closest next IGMPv3 Information Table match. In addition, the two input fields will - upon a button click - assume the value of the first displayed entry, allowing for continuous refresh with the same start address.

The will use the last entry of the currently displayed table as a basis for the next lookup. When the end is reached the text "No more entries" is shown in the displayed table. Use the button to start over.

IGMPv3 Information Table Columns

VLAN ID:

VLAN ID of the group.

Group:

Group address of the group displayed.

Port:

Switch port number.

Mode:

Indicates the filtering mode maintained per (VLAN ID, port number, Group Address) basis. It can be either Include or Exclude.

Source Address:

IP Address of the source. Currently, system limits the total number of IP source addresses for filtering to be 128.

Type:

Indicates the Type. It can be either Allow or Deny.

Auto-refresh:

Activate the auto-refresh to refresh the log automatically.

Refresh:

Refresh the IGMP Group Status manually.

<<, >>

Go to the previous/next page or entry.

3.6 MLD Snooping

Curiously enough, a network node that acts as a source of IPv6 multicast traffic is only an indirect participant in MLD snooping—it just provides multicast traffic, and MLD doesn't interact with it. (Note, however, that in an application like desktop conferencing a network node may act as both a source and an MLD host; but MLD interacts with that node only in its role as an MLD host.)

A source node creates multicast traffic by sending packets to a multicast address. In IPv6, addresses with the first eight bits set (that is, "FF" as the first two characters of the address) are multicast addresses, and any node that listens to such an address will receive the traffic sent to that address. Application software running on the source and destination systems cooperates to determine what multicast address to use. (Note that this is a function of the application software, not of MLD.)

When MLD snooping is enabled on a VLAN, the switch acts to minimize unnecessary multicast traffic. If the switch receives multicast traffic destined for a given multicast address, it forwards that traffic only to ports on the VLAN that have MLD hosts for that address. It drops that traffic for ports on the VLAN that have no MLD hosts

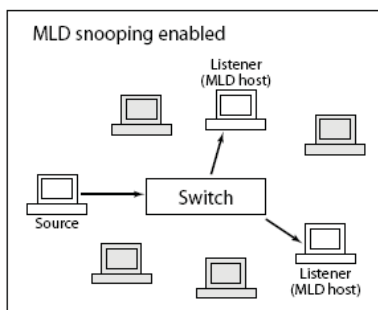

3.6.1 Basic Configuration

The section will let you understand how to configure the MLD Snooping basic configuration and the parameters.

Web Interface

To configure the MLD Snooping in the web interface:

1. Click Configuration, MLD Snooping, Basic Configuration
2. Enable or disable the Global configuration parameters
3. Activate the port to join Router port and Fast Leave.
4. Select the Throttling mode: unlimited or 1 to 10
5. Click Save to save the setting
6. If you want to cancel the setting then you need to click the Reset button. It will revert to previously saved values

Figure 3-6.1: The MLD Snooping Basic Configuration.

MLD Snooping Configuration

Global Configuration

Snooping Enabled	<input type="checkbox"/>
Unregistered IPMcV6 Flooding Enabled	<input checked="" type="checkbox"/>
MLD SSM Range	ff3e:: / 96
Proxy Enabled	<input type="checkbox"/>

Port Related Configuration

Port	Router Port	Fast Leave	Throttling
*	<input type="checkbox"/>	<input type="checkbox"/>	<>
1	<input type="checkbox"/>	<input type="checkbox"/>	unlimited
2	<input type="checkbox"/>	<input type="checkbox"/>	unlimited
3	<input type="checkbox"/>	<input type="checkbox"/>	unlimited
50	<input type="checkbox"/>	<input type="checkbox"/>	unlimited
51	<input type="checkbox"/>	<input type="checkbox"/>	unlimited
52	<input type="checkbox"/>	<input type="checkbox"/>	unlimited

Save Reset

Parameter description:

Snooping Enabled:

Enable the Global MLD Snooping.

Unregistered IPMcV6 Flooding enabled:

Enable unregistered IPMcV6 traffic flooding. Please note that disabling unregistered IPMcV6 traffic flooding may lead to failure of Neighbor Discovery.

MLD SSM Range:

SSM (Source-Specific Multicast) Range allows the SSM-aware hosts and routers run the SSM service model for the groups in the address (Using IPv6 Address) range.

Proxy Enabled:

Enable MLD Proxy. This feature can be used to avoid forwarding unnecessary join and leave messages to the router side.

Port:

The Port index what you enable or disable the MLD Snooping function.

Fast Leave:

Activate to enable the fast leave on the port.

Router Port:

Specify which ports act as router ports. A router port is a port on the Ethernet switch that leads towards the Layer 3 multicast device or MLD querier. If an aggregation member port is selected as a router port, the whole aggregation will act as a router port.

3 Configuration

Throttling:

Enable to limit the number of multicast groups to which a switch port can belong.

Buttons:

Save – Click to save changes.

Reset – Click to undo any changes made locally and revert to previously saved values.

3.6.2 VLAN Configuration

When MLD snooping is enabled on a VLAN, the switch acts to minimize unnecessary multicast traffic. If the switch receives multicast traffic destined for a given multicast address, it forwards that traffic only to ports on the VLAN that have MLD hosts for that address. It drops that traffic for ports on the VLAN that have no MLD hosts

It will use the last entry of the currently displayed entry as a basis for the next lookup. When the end is reached the text "No more entries" is shown in the displayed table.

Web Interface

To configure the MLD Snooping VLAN in the web interface:

1. Click Configuration, MLD Snooping, VLAN Configuration
2. Specify the VLAN ID with entries per page.
3. Click "Refresh" to refresh a entry of the MLD Snooping VLAN Configuration Information.
4. Click "<< or >>" to move to previous or next entry.

Figure 3-7.2: The MLD Snooping VLAN Configuration.

MLD Snooping VLAN Configuration Refresh |<< >>

Start from VLAN with entries per page.

VLAN ID	Snooping Enabled	MLD Querier	Compatibility	RV	QI (sec)	QRI (0.1 sec)	LLQI (0.1 sec)	URI (sec)
1	<input type="checkbox"/>	<input checked="" type="checkbox"/>	-	-	-	-	-	-

Parameter description:

VLAN ID:

The VLAN ID of the entry.

Snooping Enabled:

Enable the per-VLAN MLD Snooping. Only up to 32 VLANs can be selected.

MLD Querier:

A router sends MLD Query messages onto a particular link. This Router is called the Querier. Enable the MLD Querier in the VLAN.

Compatibility:

Compatibility is maintained by hosts and routers taking appropriate actions depending on the versions of MLD operating on hosts and routers within a network. The allowed selection is MLD-Auto, Forced MLDv1, Forced MLDv2, default compatibility value is MLD-Auto.

Rv:

Robustness Variable. The Robustness Variable allows tuning for the expected packet loss on a network. The allowed range is 1 to 255; default robustness variable value is 2.

QI:

Query Interval. The Query Interval is the interval between General Queries sent by the Querier. The allowed range is 1 to 31744 seconds; default query interval is 125 seconds.

QRI:

Query Response Interval. The Maximum Response Delay used to calculate the Maximum Response Code inserted into the periodic General Queries. The allowed range is 0 to 31744 in tenths of seconds; default query response interval is 100 in tenths of seconds (10 seconds).

LLQI (LMQI for IGMP):

Last Listener Query Interval. The Last Listener Query Interval is the Maximum Response Delay used to calculate the Maximum Response Code inserted into Multicast Address Specific Queries sent in response to Version 1 Multicast Listener Done messages. It is also the Maximum Response Delay used to calculate the Maximum Response Code inserted into Multicast Address and Source Specific Query messages. The allowed range is 0 to 31744 in tenths of seconds; default last listener query interval is 10 in tenths of seconds (1 second).

URI:

Unsolicited Report Interval. The Unsolicited Report Interval is the time between repetitions of a node's initial report of interest in a multicast address. The allowed range is 0 to 31744 seconds, default unsolicited report interval is 1 second.

Refresh

Refresh the IGMP Group Status manually.

<<, >>

Go to the previous/next page or entry.

Save – Click to save changes.

Reset – Click to undo any changes made locally and revert to previously saved values.

3.6.3 Port Group Filtering

The section describes how to set the Port Group Filtering in the MLD Snooping function.

Web Interface

To configure the MLD Snooping Port Group in the web interface:

1. Click Configuration, MLD Snooping, Port Group Filtering Configuration
2. Click Add new Filtering Group
3. Specify the Filtering Group
4. Click Save to save the setting
5. If you want to cancel the setting then you need to click the Reset button. It will revert to previously saved values

Figure 3-7.3: The MLD Snooping Port Group Filtering Configuration

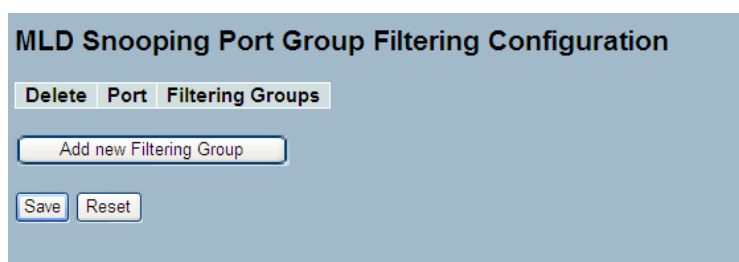

Parameter description:

Delete:

Check to delete the entry. It will be deleted during the next save.

Port:

The logical port for the settings. You can enable the port to join a filtering Group

Filtering Groups

The IP Multicast Group that will be filtered.

Buttons:

Save – Click to save changes.

Reset – Click to undo any changes made locally and revert to previously saved values.

3.6.4 Status

This section describes the MLD Snooping Status. It is helpful to find out the detailed information of the MLD Snooping status.

Web Interface

To display the MLD Snooping Status in the web interface:

1. Click Configuration, MLD Snooping, Status
2. If you want to auto-refresh the information then you need to activate "Auto-refresh"
3. Click "Refresh" to refresh a entry of the MLD Snooping Status Information.
4. Click "Clear" to clear the MLD Snooping Status.

Figure 3-6.4: The MLD Snooping Status

VLAN ID	Querier Version	Host Version	Querier Status	Queries Transmitted	Queries Received	V1 Reports Received	V2 Reports Received	V1 Leaves Received

Port	Status
1	-
2	-
3	-
4	-

Parameter description:

VLAN ID:

The VLAN ID of the entry.

Querier Version:

Working Querier Version currently.
 Host Version:
 Working Host Version currently.
 Querier Status:
 Show the Querier status is "ACTIVE" or "IDLE".
 Queries Transmitted:
 The number of Transmitted Queries.
 Queries Received:
 The number of Received Queries.
 V1 Reports Received:
 The number of Received V1 Reports.
 V2 Reports Received:
 The number of Received V2 Reports.
 V1 Leaves Received:
 The number of Received V1 Leaves.
 Auto-refresh
 Activate the auto-refresh to refresh the log automatically.
 Refresh
 Refresh the IGMP Group Status manually.
 <<,>>
 Go to the next/previous page or entry.

3.6.5 Group Information

This section describes how to set the MLD Snooping Groups Information. The "Start from VLAN", and "group" input fields allow the user to select the starting point in the MLD Group Table

Each page shows up to 99 entries from the MLD Group table, the default being 20, selected through the "entries per page" input field. When first visited, the web page will show the first 20 entries from the beginning of the MLD Group Table.

Web Interface

To display the MLD Snooping Group information in the web interface:

1. Click Configuration, MLD Snooping, Group Information
2. If you want to auto-refresh the information then you need to activate "Auto-refresh"
3. Click "Refresh" to refresh a entry of the MLD Snooping Group Information.
4. Click "Clear" to clear the MLD Snooping Groups information.

Figure 3-6.5: The MLD Snooping Groups Information

MLD Snooping Groups Information		Port Members																																
VLAN ID	Groups	1	2	3	4	5	6	7	8	9	10	11	12	13	14	15	16	17	18	19	20	21	22	23	24	25	26	27	28	29	30	31	32	33
No more entries																																		

Parameter description:

Navigating the MLD Group Table

Each page shows up to 99 entries from the MLD Group table, default being 20, selected through the "entries per page" input field. When first visited, the web page will show the first 20 entries from the beginning of the MLD Group Table. The "Start from VLAN", and "group" input fields allow the user to select the starting point in the MLD Group Table. Clicking the button will update the displayed table starting from that or the next closest.

MLD Group Table match. In addition, the two input fields will - upon a button click - assume the value of the first displayed entry, allowing for continuous refresh with the same start address. The will use the last entry of the currently displayed as a basis for the next lookup. When the end is reached the text "No more entries" is shown in the displayed table. Use the button to start over.

MLD Snooping Information Table Columns

VLAN ID:

VLAN ID of the group.

Groups:

Group address of the group displayed.

Port Members:

Ports under this group.

Auto-refresh:

Activate the auto-refresh to refresh the log automatically.

Refresh

Refresh the IGMP Group Status manually.

<<,>>

Go to the previous/next page or entry.

3.6.6 IPv6 SSM Information

This section describes how to configure the Entries in the MLDv2 Information Table that are shown on this page. The MLDv2 Information Table is sorted first by VLAN ID, then by group, and then by Port No. Different source addresses belong to the same group are treated as single entry.

Each page shows up to 64 entries from the MLDv2 SSM (Source Specific Multicast) Information table, default being 20, selected through the "entries per page" input field. When first visited, the web page will show the first 20 entries from the beginning of the MLDv2 Information Table. The "Start from VLAN", and "group" input fields allow the user to select the starting point in the MLDv2 Information Table.

Web Interface

To display the MLDv2 IPv6 SSM Information in the web interface:

1. Click Configuration, MLD Snooping, IPv6 SSM Information
2. If you want to auto-refresh the information then you need to activate "Auto-refresh".
3. Click "Refresh" to refresh a entry of the MLDv2 IPv6 SSM Information.

4. Click "<< or >>" to move to previous or next entry.

Figure 3-6.6: The IPv6 SSM Information

Parameter description:

MLDv2 Information Table Columns

VLAN ID:

VLAN ID of the group.

Group:

Group address of the group displayed.

Port:

Switch port number.

Mode:

Indicates the filtering mode maintained per (VLAN ID, port number, Group Address) basis. It can be either Include or Exclude.

Source Address:

IP Address of the source. Currently, system limits the total number of IP source addresses for filtering to be 128.

Type:

Indicates the Type. It can be either Allow or Deny.

Refresh:

Refresh the MLDv2 Information Table manually.

<<,>>

Go to the previous/next page or entry.

3.7 MVR

The MVR feature enables multicast traffic forwarding on the Multicast VLAN. In a multicast television application, a PC or a television with a set-top box can receive the multicast stream. Multiple set-top boxes or PCs can be connected to one subscriber port, which is a switch port configured as an MVR receiver port. When a subscriber selects a channel, the set-top box or PC sends an IGMP join message to Switch A to join the appropriate multicast. Uplink ports that send and receive multicast data to and from the multicast VLAN are called MVR source ports.

3.7.1 Configuration

This section describes how to set the MVR basic Configuration.

Web Interface

To configure the MVR in the web interface:

3 Configuration

1. Click Configuration, MVR, Configuration
2. Enable or disable MVR by selecting the mode.
3. Set the other parameters.
4. Click Save to save the setting
5. If you want to cancel the setting then you need to click the Reset button. It will revert to previously saved values

Figure 3-7.1: The MVR Configuration

MVR Configuration

MVR Mode: Disabled
 VLAN ID: 100

Port Configuration

Port	Mode	Type	Immediate Leave
*	<>	<>	<>
1	Disabled	Receiver	Disabled
2	Disabled	Receiver	Disabled
3	Disabled	Receiver	Disabled
50	Disabled	Receiver	Disabled
51	Disabled	Receiver	Disabled
52	Disabled	Receiver	Disabled

Save Reset

Parameter description:

MVR Mode:

Enable/Disable the Global MVR.

VLAN ID:

Specify the Multicast VLAN ID.

Mode:

Enable MVR on the port.

Type:

Specify the MVR port type on the port.

Immediate Leave:

Enable the fast leave on the port.

Buttons:

Save – Click to save changes.

Reset – Click to undo any changes made locally and revert to previously saved values.

3.7.2 Groups Information

This section describes how to display the MVR Groups information. Entries in the MVR Group Table are shown on this page. The MVR Group Table is sorted first by VLAN ID, and then by group

Web Interface

To display the MVR Groups Information in the web interface:

1. Click Configuration, MVR, Groups Information

2. If you want to auto-refresh the information then you need to activate "Auto-refresh".
3. To Click the "Refresh" to refresh a entry of the MVR Groups Information.
4. Click "<< or >>" to move to previous or next entry.

Figure 3-7.2: The MVR Groups Information

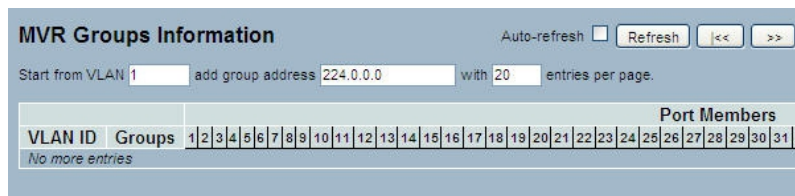

Parameter description:

MVR Group Table Columns

VLAN ID:

VLAN ID of the group.

Groups:

Group ID of the group displayed.

Port Members:

Ports under this group.

Auto-refresh:

Activate the auto-refresh to refresh the information automatically.

Refresh

Refresh the MVR Group information manually.

<<, >>

Go to the previous/next page or entry.

3.7.3 Statistics

This section describes how to display the MVR detail Statistics after you configured MVR on the switch. It provides the detailed MVR Statistics Information

Web Interface

To display the MVR Statistics Information in the web interface:

1. Click Configuration, MVR, Statistics
2. If you want to auto-refresh the information then you need to activate "Auto-refresh".
3. To Click the "Refresh" to refresh a entry of the MVR Statistics Information.
4. Click "<< or >>" to move to previous or next entry.

Figure 3-7.3: The MVR Statistics Information

MVR Statistics				
VLAN ID	V1 Reports Received	V2 Reports Received	V3 Reports Received	V2 Leaves Received
100	0	0	0	0

Auto-refresh Refresh Clear

Parameter description:

VLAN ID:

The Multicast VLAN ID.

V1 Reports Received:

The number of Received V1 Reports.

V2 Reports Received:

The number of Received V2 Reports.

V3 Reports Received:

The number of Received V3 Reports.

V2 Leaves Received:

The number of Received V2 Leaves.

Auto-refresh:

Activate the auto-refresh to refresh the information automatically.

Refresh

Refresh the MVR Group information manually.

<<, >>

Go to the previous/next page or entry.

3.8 LLDP

The switch supports the LLDP. The Link Layer Discovery Protocol (LLDP) provides a standards-based method for enabling switches to advertise themselves to adjacent devices and to learn about adjacent LLDP devices. The Link Layer Discovery Protocol (LLDP) is a vendor-neutral Link Layer protocol in the Internet Protocol Suite used by network devices for advertising their identity, capabilities, and neighbors on a IEEE 802 local area network, principally wired Ethernet. The protocol is formally referred to by the IEEE as Station and Media Access Control Connectivity Discovery specified in standards document IEEE 802.1AB.

3.8.1 LLDP Configuration

You can configure LLDP and the detail parameters per port, the settings will take effect immediately. This page allows the user to inspect and configure the current LLDP port settings.

Web Interface

To configure LLDP:

1. Click LLDP configuration

2. Modify LLDP timing parameters
3. Set the required mode for transmitting or receiving LLDP messages
4. Specify the information to include in the TLV field of advertised messages
5. Click Save

Figure 3-8.1: The LLDP Configuration

LLDP Configuration

LLDP Parameters

Tx Interval	30	seconds
Tx Hold	4	times
Tx Delay	2	seconds
Tx Reinit	2	seconds

Port	Mode	CDP aware	Optional TLVs				
			Port Descr	Sys Name	Sys Descr	Sys Capa	Mgmt Addr
*	<>	<input type="checkbox"/>	<input checked="" type="checkbox"/>	<input checked="" type="checkbox"/>	<input checked="" type="checkbox"/>	<input checked="" type="checkbox"/>	<input checked="" type="checkbox"/>
1	Disabled	<input type="checkbox"/>	<input checked="" type="checkbox"/>	<input checked="" type="checkbox"/>	<input checked="" type="checkbox"/>	<input checked="" type="checkbox"/>	<input checked="" type="checkbox"/>
2	Disabled	<input type="checkbox"/>	<input checked="" type="checkbox"/>	<input checked="" type="checkbox"/>	<input checked="" type="checkbox"/>	<input checked="" type="checkbox"/>	<input checked="" type="checkbox"/>
3	Disabled	<input type="checkbox"/>	<input checked="" type="checkbox"/>	<input checked="" type="checkbox"/>	<input checked="" type="checkbox"/>	<input checked="" type="checkbox"/>	<input checked="" type="checkbox"/>
50	Disabled	<input type="checkbox"/>	<input checked="" type="checkbox"/>	<input checked="" type="checkbox"/>	<input checked="" type="checkbox"/>	<input checked="" type="checkbox"/>	<input checked="" type="checkbox"/>
51	Disabled	<input type="checkbox"/>	<input checked="" type="checkbox"/>	<input checked="" type="checkbox"/>	<input checked="" type="checkbox"/>	<input checked="" type="checkbox"/>	<input checked="" type="checkbox"/>
52	Disabled	<input type="checkbox"/>	<input checked="" type="checkbox"/>	<input checked="" type="checkbox"/>	<input checked="" type="checkbox"/>	<input checked="" type="checkbox"/>	<input checked="" type="checkbox"/>

Save Reset

Parameter description:

LLDP Parameters

Tx Interval:

The switch periodically transmits LLDP frames to its neighbors for having the network discovery information up-to-date. The interval between each LLDP frame is determined by the Tx Interval value. Valid values are restricted to 5 - 32768 seconds.

Tx Hold:

Each LLDP frame contains information about how long the information in the LLDP frame shall be considered valid. The LLDP information valid period is set to Tx Hold multiplied by Tx Interval seconds. Valid values are restricted to 2 - 10 times.

Tx Delay:

If some configuration is changed (e.g. the IP address) a new LLDP frame is transmitted, but the time between the LLDP frames will always be at least the value of Tx Delay seconds. Tx Delay cannot be larger than 1/4 of the Tx Interval value. Valid values are restricted to 1 - 8192 seconds.

Tx Reinit:

When a port is disabled, LLDP is disabled or the switch is rebooted, an LLDP shutdown frame is transmitted to the neighboring units, signaling that the LLDP information isn't valid anymore. Tx Reinit controls the amount of seconds between the shutdown frame and a new LLDP initialization. Valid values are restricted to 1 - 10 seconds.

LLDP Port Configuration

The LLDP port settings relate to the currently selected, as reflected by the page header.

Port:

The switch port number of the logical LLDP port.

Mode:

Select LLDP mode.

Rx only The switch will not send out LLDP information, but LLDP information from neighbor units is analyzed.

Tx only The switch will drop LLDP information received from neighbors, but will send out LLDP information.

Disabled The switch will not send out LLDP information, and will drop LLDP information received from neighbors.

Enabled the switch will send out LLDP information, and will analyze LLDP information received from neighbors.

CDP Aware:

Select CDP awareness.

The CDP operation is restricted to decoding incoming CDP frames (The switch doesn't transmit CDP frames). CDP frames are only decoded if LLDP on the port is enabled.

Only CDP TLVs that can be mapped to a corresponding field in the LLDP neighbors' table are decoded. All other TLVs are discarded (Unrecognized CDP TLVs and discarded CDP frames are not shown in the LLDP statistics.). CDP TLVs are mapped onto LLDP neighbors' table as shown below.

CDP TLV "Device ID" is mapped to the LLDP "Chassis ID" field.

CDP TLV "Address" is mapped to the LLDP "Management Address" field. The CDP address TLV can contain multiple addresses, but only the first address is shown in the LLDP neighbors' table.

CDP TLV "Port ID" is mapped to the LLDP "Port ID" field.

CDP TLV "Version and Platform" is mapped to the LLDP "System Description" field.

Both the CDP and LLDP support "system capabilities", but the CDP capabilities cover capabilities that are not part of the LLDP. These capabilities are shown as "others" in the LLDP neighbors' table.

If all ports have CDP awareness disabled the switch forwards CDP frames received from neighbor devices. If at least one port has CDP awareness enabled all CDP frames are terminated by the switch.

 When CDP awareness on a port is disabled the CDP information isn't removed immediately, but when the hold time is exceeded.

Port Descr:

Optional TLV: When checked the "port description" is included in LLDP information transmitted.

Sys Name:

Optional TLV: When checked the "system name" is included in LLDP information transmitted.

Sys Descr:

Optional TLV: When checked the "system description" is included in LLDP information transmitted.

Sys Capa:

Optional TLV: When checked the "system capability" is included in LLDP information transmitted.

Mgmt Addr:

Optional TLV: When checked the "management address" is included in LLDP information transmitted.

Buttons:

Save – Click to save changes.

Reset – Click to undo any changes made locally and revert to previously saved values.

3.8.2 LLDP Neighbors

This page provides a status overview for all LLDP neighbors. The displayed table contains a row for each port on which an LLDP neighbor is detected. The columns hold the following information:

Web Interface

To show LLDP neighbors:

1. Click LLDP Neighbors
2. Click Refresh for manual update web screen
3. Click Auto-refresh for auto-update web screen

Figure 3-8.2: The LLDP Neighbors information

Local Port	Chassis ID	Remote Port ID	System Name	Port Description	System Capabilities	System Description	Management Address
No LLDP neighbour information found							

! If your network without any device supports LLDP then the table will show "No LLDP neighbor information found".

Parameter description:

Local Port:

The port on which the LLDP frame was received.

Chassis ID:

The Chassis ID is the identification of the neighbor's LLDP frames.

Remote Port ID:

The Remote Port ID is the identification of the neighbor port.

System Name:

System Name is the name advertised by the neighbor unit.

Port Description:

Port Description is the port description advertised by the neighbor unit.

System Capabilities:

System Capabilities describes the neighbor unit's capabilities. The possible capabilities are:

1. Other
2. Repeater
3. Bridge
4. WLAN Access Point
5. Router
6. Telephone
7. DOCSIS cable device
8. Station only
9. Reserved

When a capability is enabled, the capability is followed by (+). If the capability is disabled, the capability is followed by (-).

System Description:

System Description is the port description advertised by the neighbor unit.

Management Address:

3 Configuration

Management Address is the neighbor unit's address that is used for higher layer entities to assist discovery by the network management. This could for instance hold the neighbor's IP address.

Auto-refresh:

Activate the auto-refresh to the information automatically.

Refresh:

Refresh the LLDP Neighbors information manually.

3.8.3 LLDP-MED Configuration

Media Endpoint Discovery is an enhancement of LLDP, known as LLDP-MED, which provides the following facilities:

Auto-discovery of LAN policies (such as VLAN, Layer 2 Priority and Differentiated services (Diffserv) settings) enabling plug and play networking.

Device location discovery allows creation of location databases and, in the case of Voice over Internet Protocol (VoIP), Enhanced 911 services.

Extended and automated power management of Power over Ethernet (PoE) end points.

Inventory management, allowing network administrators to track their network devices, and determine their characteristics (manufacturer, software and hardware versions, serial or asset number).

This page allows you to configure the LLDP-MED. This function applies to VoIP devices which support LLDP-MED.

Web Interface

To configure LLDP-MED:

1. Click LLDP-MED Configuration
2. Modify Fast start repeat count parameter, default is 4
3. Modify Coordinates Location parameters
4. Fill Civic Address Location parameters
5. Add new policy
6. Click Save, will show following Policy Port Configuration
7. Select Policy ID for each port
8. Click Save

Figure 3-8.3: The LLDP-MED Configuration

LLDPMED Configuration

Fast Start Repeat Count

Fast start repeat count

Coordinates Location

Latitude degrees Longitude degrees Altitude Meters WGS84

Civic Address Location

Country code	<input type="text"/>	State	<input type="text"/>	County	<input type="text"/>
City	<input type="text"/>	City district	<input type="text"/>	Block (Neighbourhood)	<input type="text"/>
Street	<input type="text"/>	Leading street direction	<input type="text"/>	Trailing street suffix	<input type="text"/>
Street suffix	<input type="text"/>	House no.	<input type="text"/>	House no. suffix	<input type="text"/>
Landmark	<input type="text"/>	Additional location info	<input type="text"/>	Name	<input type="text"/>
Zip code	<input type="text"/>	Building	<input type="text"/>	Apartment	<input type="text"/>
Floor	<input type="text"/>	Room no.	<input type="text"/>	Place type	<input type="text"/>
Postal community name	<input type="text"/>	P.O. Box	<input type="text"/>	Additional code	<input type="text"/>

Emergency Call Service

Emergency Call Service

Policies

Policy Port Configuration

Policies

Delete	Policy ID	Application Type	Tag	VLAN ID	L2 Priority	DSCP
<input type="button" value="Delete"/>	0	Voice	Tagged	1	0	0
<input type="button" value="Delete"/>	1	Voice	Tagged	1	0	0

Parameter description:

Fast start repeat count

Rapid startup and Emergency Call Service Location Identification Discovery of endpoints is a critically important aspect of VoIP systems in general. In addition, it is best to advertise only those pieces of information which are specifically relevant to particular endpoint types (for example only advertise the voice network policy to permitted voice-capable devices), both in order to conserve the limited LLDPDU space and to reduce security and system integrity issues that can come with inappropriate knowledge of the network policy.

With this in mind LLDP-MED defines an LLDP-MED Fast Start interaction between the protocol and the application layers on top of the protocol, in order to achieve these related properties. Initially, a Network Connectivity Device will only transmit LLDP TLVs in an LLDPDU. Only after an LLDP-MED Endpoint Device is detected, will an LLDP-MED capable Network Connectivity Device start to advertise LLDP-MED TLVs in outgoing LLDPDUs on the associated port. The LLDP-MED application will temporarily speed up the transmission of the LLDPDU to start within a second, when a new LLDP-MED neighbor has been detected in order share LLDP-MED information as fast as possible to new neighbors.

Because there is a risk of an LLDP frame being lost during transmission between neighbors, it is recommended to repeat the fast start transmission multiple times to increase the possibility of the neighbors receiving the LLDP frame. With Fast start repeat count it is possible to specify the number of times the fast start transmission would be repeated. The recommended value is 4 times, given that 4 LLDP frames with a 1 second interval will be transmitted, when an LLDP frame with new information is received.

It should be noted that LLDP-MED and the LLDP-MED Fast Start mechanism is only intended to run on links between LLDP-MED Network Connectivity Devices and Endpoint Devices, and as such does not apply to links between LAN infrastructure elements, including Network Connectivity Devices, or other types of links.

Coordinates Location

Latitude:

3 Configuration

Latitude SHOULD be normalized to within 0-90 degrees with a maximum of 4 digits.

It is possible to specify the direction to either North of the equator or South of the equator.

Longitude:

Longitude SHOULD be normalized to within 0-180 degrees with a maximum of 4 digits.

It is possible to specify the direction to either East of the prime meridian or West of the prime meridian.

Altitude:

Altitude SHOULD be normalized to within -32767 to 32767 with a maximum of 4 digits.

It is possible to select between two altitude types (floors or meters).

Meters: Representing meters of Altitude defined by the vertical datum specified.

Floors: Representing altitude in a form more relevant in buildings which have different floor-to-floor dimensions. An altitude = 0.0 is meaningful even outside a building, and represents ground level at the given latitude and longitude. Inside a building, 0.0 represents the floor level associated with ground level at the main entrance.

Map Datum:

The Map Datum is used for the coordinates given in these options:

WGS84: (Geographical 3D) - World Geodesic System 1984, CRS Code 4327, Prime Meridian Name: Greenwich.

NAD83/NAVD88: North American Datum 1983, CRS Code 4269, Prime Meridian Name: Greenwich; the associated vertical datum is the North American Vertical Datum of 1988 (NAVD88). This datum pair is to be used when referencing locations on land, not near tidal water (which would use Datum = NAD83/MLLW).

NAD83/MLLW: North American Datum 1983, CRS Code 4269, Prime Meridian Name: Greenwich; the associated vertical datum is Mean Lower Low Water (MLLW). This datum pair is to be used when referencing locations on water/sea/ocean.

Civic Address Location

IETF Geopriv Civic Address based Location Configuration Information (Civic Address LCI).

Country code:

The two-letter ISO 3166 country code in capital ASCII letters - Example: DK, DE or US.

State:

National subdivisions (state, canton, region, province, prefecture).

County:

County, parish, gun (Japan), district.

City:

City, township, shi (Japan) - Example: Copenhagen.

City district:

City division, borough, city district, ward, chou (Japan).

Block (Neighborhood):

Neighborhood, block.

Street:

Street - Example: Poppelvej.

Leading street direction:

Leading street direction - Example: N.

Trailing street suffix:

Trailing street suffix - Example: SW.

Street suffix:

Street suffix - Example: Ave, Platz.

House no.:

House number - Example: 21.

House no. suffix:

House number suffix - Example: A, 1/2.

Landmark:

Landmark or vanity address - Example: Columbia University.

Additional location info:

Additional location info - Example: South Wing.

Name:

Name (residence and office occupant) - Example: Flemming Jahn.

Zip code:

Postal/zip code - Example: 2791.

Building:

Building (structure) - Example: Low Library.

Apartment:

Unit (Apartment, suite) - Example: Apt 42.

Floor:

Floor - Example: 4.

Room no.:

Room number - Example: 450F.

Place type:

Place type - Example: Office.

Postal community name:

Postal community name - Example: Leonia.

P.O. Box:

Post office box (P.O. BOX) - Example: 12345.

Additional code:

Additional code - Example: 1320300003.

Emergency Call Service:

Emergency Call Service (e.g. E911 and others), such as defined by TIA or NENA.

Emergency Call Service:

Emergency Call Service ELIN identifier data format is defined to carry the ELIN identifier as used during emergency call setup to a traditional CAMA or ISDN trunk-based PSAP. This format consists of a numerical digit string, corresponding to the ELIN to be used for emergency calling.

Policies

3 Configuration

Network Policy Discovery enables the efficient discovery and diagnosis of mismatch issues with the VLAN configuration, along with the associated Layer 2 and Layer 3 attributes, which apply for a set of specific protocol applications on that port. Improper network policy configurations are a very significant issue in VoIP environments that frequently result in voice quality degradation or loss of service.

Policies are only intended for use with applications that have specific 'real-time' network policy requirements, such as interactive voice and/or video services.

The network policy attributes advertised are:

1. Layer 2 VLAN ID (IEEE 802.1Q-2003)
2. Layer 2 priority value (IEEE 802.1D-2004)
3. Layer 3 Diffserv code point (DSCP) value (IETF RFC 2474)

This network policy is potentially advertised and associated with multiple sets of application types supported on a given port. The application types specifically addressed are:

1. Voice
2. Guest Voice
3. Softphone Voice
4. Video Conferencing
5. Streaming Video
6. Control / Signaling (conditionally support a separate network policy for the media types above)

A large network may support multiple VoIP policies across the entire organization, and different policies per application type. LLDP-MED allows multiple policies to be advertised per port, each corresponding to a different application type. Different ports on the same Network Connectivity Device may advertise different sets of policies, based on the authenticated user identity or port configuration.

It should be noted that LLDP-MED is not intended to run on links other than between Network Connectivity Devices and Endpoints, and therefore does not need to advertise the multitude of network policies that frequently run on an aggregated link interior to the LAN.

Delete:

Check to delete the policy. It will be deleted during the next save.

Policy ID:

ID for the policy. This is auto generated and shall be used when selecting the policies that shall be mapped to the specific ports.

Application Type:

Intended use of the application types:

1. Voice - for use by dedicated IP Telephony handsets and other similar appliances supporting interactive voice services. These devices are typically deployed on a separate VLAN for ease of deployment and enhanced security by isolation from data applications.
2. Voice Signaling (conditional) - for use in network topologies that require a different policy for the voice signaling than for the voice media. This application type should not be advertised if all the same network policies apply as those advertised in the Voice application policy.
3. Guest Voice - support a separate 'limited feature-set' voice service for guest users and visitors with their own IP Telephony handsets and other similar appliances supporting interactive voice services.
4. Guest Voice Signaling (conditional) - for use in network topologies that require a different policy for the guest voice signaling than for the guest voice media. This application type should not be advertised if all the same network policies apply as those advertised in the Guest Voice application policy.

5. Softphone Voice - for use by softphone applications on typical data centric devices, such as PCs or laptops. This class of endpoints frequently does not support multiple VLANs, if at all, and are typically configured to use an 'untagged' VLAN or a single 'tagged' data specific VLAN. When a network policy is defined for use with an 'untagged' VLAN (see Tagged flag below), then the L2 priority field is ignored and only the DSCP value has relevance.

6. Video Conferencing - for use by dedicated Video Conferencing equipment and other similar appliances supporting real-time interactive video/audio services.

7. Streaming Video - for use by broadcast or multicast based video content distribution and other similar applications supporting streaming video services that require specific network policy treatment. Video applications relying on TCP with buffering would not be an intended use of this application type.

8. Video Signaling (conditional) - for use in network topologies that require a separate policy for the video signaling than for the video media. This application type should not be advertised if all the same network policies apply as those advertised in the Video Conferencing application policy.

Tag:

Tag indicating whether the specified application type is using a 'tagged' or an 'untagged' VLAN.

Untagged indicates that the device is using an untagged frame format and as such does not include a tag header as defined by IEEE 802.1Q-2003. In this case, both the VLAN ID and the Layer 2 priority fields are ignored and only the DSCP value has relevance.

Tagged indicates that the device is using the IEEE 802.1Q tagged frame format, and that both the VLAN ID and the Layer 2 priority values are being used, as well as the DSCP value. The tagged format includes an additional field, known as the tag header. The tagged frame format also includes priority tagged frames as defined by IEEE 802.1Q-2003.

VLAN ID:

VLAN identifier (VID) for the port as defined in IEEE 802.1Q-2003.

L2 Priority:

L2 Priority is the Layer 2 priority to be used for the specified application type. L2 Priority may specify one of eight priority levels (0 through 7), as defined by IEEE 802.1D-2004. A value of 0 represents use of the default priority as defined in IEEE 802.1D-2004.

DSCP:

DSCP value to be used to provide Diffserv node behavior for the specified application type as defined in IETF RFC 2474. DSCP may contain one of 64 code point values (0 through 63). A value of 0 represents use of the default DSCP value as defined in RFC 2475.

Adding a new policy:

Click to add a new policy. Specify the Application type, Tag, VLAN ID, L2 Priority and DSCP for the new policy. Click "Save".

Port Policies Configuration:

Every port may advertise a unique set of network policies or different attributes for the same network policies, based on the authenticated user identity or port configuration.

Port:

The port number to which the configuration applies.

Policy Id:

The set of policies that shall apply to a given port. The set of policies is selected by check marking the checkboxes that corresponds to the policies.

Buttons:

Save – Click to save changes.

Reset – Click to undo any changes made locally and revert to previously saved values.

3.8.4 LLDP-MED Neighbors

This page provides a status overview of all LLDP-MED neighbors. The displayed table contains a row for each port on which an LLDP neighbor is detected. This function applies to VoIP devices which support LLDP-MED. The columns hold the following information:

Web Interface

To show LLDP-MED neighbor:

1. Click LLDP-MED Neighbor
2. Click Refresh for manual update web screen
3. Click Auto-refresh for auto-update web screen

Figure 3-9.4: The LLDP-MED Neighbors information



 If your network without any device supports LLDP-MED then the table will show “No LLDP-MED neighbor information found”.

Parameter description:

Port:

The port on which the LLDP frame was received.

Device Type:

LLDP-MED Devices are comprised of two primary Device Types: Network Connectivity Devices and Endpoint Devices.

LLDP-MED Network Connectivity Device Definition

LLDP-MED Network Connectivity Devices, as defined in TIA-1057, provide access to the IEEE 802 based LAN infrastructure for LLDP-MED Endpoint Devices. An LLDP-MED Network Connectivity Device is a LAN access device based on any of the following technologies:

1. LAN Switch/Router
2. IEEE 802.1 Bridge
3. IEEE 802.3 Repeater (included for historical reasons)
4. IEEE 802.11 Wireless Access Point
5. Any device that supports the IEEE 802.1AB and MED extensions defined by TIA-1057 and can relay IEEE 802 frames via any method.

LLDP-MED Endpoint Device Definition:

LLDP-MED Endpoint Devices, as defined in TIA-1057, are located at the IEEE 802 LAN network edge, and participate in IP communication service using the LLDP-MED framework.

Within the LLDP-MED Endpoint Device category, the LLDP-MED scheme is broken into further Endpoint Device Classes, as defined in the following.

Each LLDP-MED Endpoint Device Class is defined to build upon the capabilities defined for the previous Endpoint Device Class. For-example will any LLDP-MED Endpoint Device claiming compliance as a Media Endpoint (Class II) also support all aspects of TIA-1057 applicable to Generic Endpoints (Class I), and any LLDP-MED Endpoint Device claiming compliance as a Communication Device (Class III) will also support all aspects of TIA-1057 applicable to both Media Endpoints (Class II) and Generic Endpoints (Class I).

LLDP-MED Generic Endpoint (Class I):

The LLDP-MED Generic Endpoint (Class I) definition is applicable to all endpoint products that require the base LLDP discovery services defined in TIA-1057, however do not support IP media or act as an end-user communication appliance. Such devices may include (but are not limited to) IP Communication Controllers, other communication related servers, or any device requiring basic services as defined in TIA-1057.

Discovery services defined in this class include LAN configuration, device location, network policy, power management, and inventory management.

LLDP-MED Media Endpoint (Class II):

The LLDP-MED Media Endpoint (Class II) definition is applicable to all endpoint products that have IP media capabilities however may or may not be associated with a particular end user. Capabilities include all of the capabilities defined for the previous Generic Endpoint Class (Class I), and are extended to include aspects related to media streaming. Example product categories expected to adhere to this class include (but are not limited to) Voice / Media Gateways, Conference Bridges, Media Servers, and similar.

Discovery services defined in this class include media-type-specific network layer policy discovery.

LLDP-MED Communication Endpoint (Class III):

The LLDP-MED Communication Endpoint (Class III) definition is applicable to all endpoint products that act as end user communication appliances supporting IP media. Capabilities include all of the capabilities defined for the previous Generic Endpoint (Class I) and Media Endpoint (Class II) classes, and are extended to include aspects related to end user devices. Example product categories expected to adhere to this class include (but are not limited to) end user communication appliances, such as IP Phones, PC-based softphones, or other communication appliances that directly support the end user.

Discovery services defined in this class include provision of location identifier (including ECS / E911 information), embedded L2 switch support, and inventory management.

LLDP-MED Capabilities:

LLDP-MED Capabilities describes the neighborhood unit's LLDP-MED capabilities. The possible capabilities are:

1. LLDP-MED capabilities
2. Network Policy
3. Location Identification
4. Extended Power via MDI - PSE
5. Extended Power via MDI - PD
6. Inventory
7. Reserved

Application Type:

Application Type indicating the primary function of the application(s) defined for this network policy, advertised by an Endpoint or Network Connectivity Device. The possible application types are shown below.

1. Voice - for use by dedicated IP Telephony handsets and other similar appliances supporting interactive voice services. These devices are typically deployed on a separate VLAN for ease of deployment and enhanced security by isolation from data applications.
2. Voice Signaling - for use in network topologies that require a different policy for the voice signaling than for the voice media.
3. Guest Voice - to support a separate limited feature-set voice service for guest users and visitors with their own IP Telephony handsets and other similar appliances supporting interactive voice services.
4. Guest Voice Signaling - for use in network topologies that require a different policy for the guest voice signaling than for the guest voice media.

5. Softphone Voice - for use by softphone applications on typical data centric devices, such as PCs or laptops.
6. Video Conferencing - for use by dedicated Video Conferencing equipment and other similar appliances supporting real-time interactive video/audio services.
7. Streaming Video - for use by broadcast or multicast based video content distribution and other similar applications supporting streaming video services that require specific network policy treatment. Video applications relying on TCP with buffering would not be an intended use of this application type.
8. Video Signaling - for use in network topologies that require a separate policy for the video signaling than for the video media.

Policy:

Policy indicates that an Endpoint Device wants to explicitly advertise that the policy is required by the device. Can be either Defined or Unknown

Unknown: The network policy for the specified application type is currently unknown.

Defined: The network policy is defined.

TAG:

TAG is indicative of whether the specified application type is using a tagged or an untagged VLAN. Can be Tagged or Untagged.

Untagged: The device is using an untagged frame format and as such does not include a tag header as defined by IEEE 802.1Q-2003.

Tagged: The device is using the IEEE 802.1Q tagged frame format.

VLAN ID:

VLAN ID is the VLAN identifier (VID) for the port as defined in IEEE 802.1Q-2003. A value of 1 through 4094 is used to define a valid VLAN ID. A value of 0 (Priority Tagged) is used if the device is using priority tagged frames as defined by IEEE 802.1Q-2003, meaning that only the IEEE 802.1D priority level is significant and the default PVID of the ingress port is used instead.

Priority:

Priority is the Layer 2 priority to be used for the specified application type. One of the eight priority levels (0 through 7).

DSCP:

DSCP is the DSCP value to be used to provide Diffserv node behavior for the specified application type as defined in IETF RFC 2474. Contain one of 64 code point values (0 through 63).

3.8.5 EEE

By using EEE power savings can be achieved at the expense of traffic latency. This latency occurs due to the circuits EEE turns off to save power, need time to boot up before sending traffic over the link. This time is called "wakeup time". To achieve minimal latency, devices can use LLDP to exchange information about their respective tx and rx "wakeup time", as a way to agree upon the minimum wakeup time they need.

This page provides an overview of EEE information exchanged by LLDP.

Web Interface

To show LLDP EEE neighbors:

1. Click LLDP, then click EEE to show discover EEE devices
2. Click Refresh for manual update web screen
3. Click Auto-refresh for auto-update web screen

Figure 3-8.5: The LLDP Neighbors EEE information

LLDP Neighbors EEE Information								Auto-refresh <input type="checkbox"/>	Refresh
Local Port	Tx Tw	Rx Tw	Fallback Receive Tw	Echo Tx Tw	Echo Rx Tw	Resolved Tx Tw	Resolved Rx Tw	EEE activated	
No LLDP EEE information found									

 If your network without any devices which enables EEE function then the table will show “No LLDP EEE information found”.

Parameter description:

Local Port:

The port on which LLDP frames are received or transmitted.

Tx Tw:

The link partner’s maximum time that transmit path can hold off sending data after reassertion of LPI.

Rx Tw:

The link partner’s time that receiver would like the transmitter to hold off to allow time for the receiver to wake from sleep.

Fallback Receive Tw:

The link partner’s fallback receives Tw.

A receiving link partner may inform the transmitter of an alternate desired Tw_sys_tx. Since a receiving link partner is likely to have discrete levels for savings, this provides the transmitter with additional information that it may use for a more efficient allocation. Systems that do not implement this option default the value to be the same as that of the Receive Tw_sys_tx.

Echo Tx Tw:

The link partner's Echo Tx Tw value.

The respective echo values shall be defined as the local link partners’ reflection (echo) of the remote link partners’ respective values. When a local link partner receives its echoed values from the remote link partner it can determine whether or not the remote link partner has received, registered and processed its most recent values. For example, if the local link partner receives echoed parameters that do not match the values in its local MIB, then the local link partner infers that the remote link partners request was based on stale information.

Echo Rx Tw:

The link partner's Echo Rx Tw value.

Resolved Tx Tw:

The resolved Tx Tw for this link. Note: NOT the link partner

The resolved value that is the actual “tx wakeup time” used for this link (based on EEE information exchanged via LLDP).

Resolved Rx Tw:

The resolved Rx Tw for this link. Note: NOT the link partner

The resolved value that is the actual “tx wakeup time” used for this link (based on EEE information exchanged via LLDP).

Auto-refresh:

Activate the auto-refresh to refresh the information automatically.

Refresh

Refresh the LLDP Neighbors information manually.

3.8.6 Port Statistics

Two types of counters are shown. Global counters are counters that refer to the whole switch, while local counters refer to per port counters for the currently selected switch

Web Interface

To show LLDP Statistics:

1. Click LLDP, then click Port Statistics to show LLDP counters
2. Click Refresh for manual update of the view
3. Click Auto-refresh for auto-update web screen
4. Click Clear to clear all counters

Figure 3-8.6: The LLDP Port Statistics information

The screenshot displays the LLDP Port Statistics web interface. At the top right, there are controls for 'Auto-refresh' (unchecked), 'Refresh', and 'Clear'. Below this, the 'Global Counters' section shows a table with the following data:

Global Counters	
Neighbour entries were last changed	2011-01-01 00:00:00 (22527 sec. ago)
Total Neighbours Entries Added	0
Total Neighbours Entries Deleted	0
Total Neighbours Entries Dropped	0
Total Neighbours Entries Aged Out	0

Below the Global Counters is the 'LLDP Statistics' section, which contains a table for 'Local Counters' with the following data:

Local Counters								
Local Port	Tx Frames	Rx Frames	Rx Errors	Frames Discarded	TLVs Discarded	TLVs Unrecognized	Org. Discarded	Age-Outs
1	0	0	0	0	0	0	0	0
2	0	0	0	0	0	0	0	0
3	0	0	0	0	0	0	0	0

Parameter description:

Global Counters

Neighbor entries were last changed at:

It also shows the time when the last entry was last deleted or added. It also shows the time elapsed since the last change was detected.

Total Neighbors Entries Added:

Shows the number of new entries added since switch reboot.

Total Neighbors Entries Deleted:

Shows the number of new entries deleted since switch reboot.

Total Neighbors Entries Dropped:

Shows the number of LLDP frames dropped due to the entry table being full.

Total Neighbors Entries Aged Out:

Shows the number of entries deleted due to Time-To-Live expiring.

Local Counters

The displayed table contains a row for each port. The columns hold the following information:

Local Port:

The port on which LLDP frames are received or transmitted.

Tx Frames:

The number of LLDP frames transmitted on the port.

Rx Frames:

The number of LLDP frames received on the port.

Rx Errors:

The number of received LLDP frames containing some kind of error.

Frames Discarded:

If an LLDP frame is received on a port, and the switch's internal table has run full, the LLDP frame is counted and discarded. This situation is known as "Too Many Neighbors" in the LLDP standard. LLDP frames require a new entry in the table when the Chassis ID or Remote Port ID is not already contained within the table. Entries are removed from the table when a given port's link is down, an LLDP shutdown frame is received, or when the entry ages out.

TLVs Discarded:

Each LLDP frame can contain multiple pieces of information, known as TLVs (TLV is short for "Type Length Value"). If a TLV is malformed, it is counted and discarded.

TLVs Unrecognized:

The number of well-formed TLVs, but with an unknown type value.

Org. Discarded:

The number of organizationally received TLVs.

Age-Outs:

Each LLDP frame contains information about how long time the LLDP information is valid (age-out time). If no new LLDP frame is received within the age out time, the LLDP information is removed, and the Age-Out counter is incremented.

Auto-refresh:

Activate the auto-refresh to refresh the information automatically.

Refresh:

Refresh the LLDP Port Statistics information manually.

Clear:

Press clear to clean up the entries.

3.9 Filtering Data Base

The Filtering Data Base Configuration includes many functions, including MAC Table Information, Static MAC Learning, which cannot be categorized to some function type.

MAC table

Switching of frames is based upon the DMAC address contained in the frame. The switch builds up a table that maps MAC addresses to switch ports for knowing which ports the frames should go to (based upon the DMAC address in the frame). This table contains both static and dynamic entries. The static entries are configured by the network administrator if the administrator wants to do a fixed mapping between the DMAC address and switch ports.

The frames also contain a MAC address (SMAC address), which shows the MAC address of the equipment sending the frame. The SMAC address is used by the switch to automatically update the MAC table with these dynamic MAC addresses. Dynamic entries are removed from the MAC table if no frame with the corresponding SMAC address has been seen after a configurable age time

3.9.1 Configuration

The MAC Address Table is configured on this page. Set timeouts for entries in the dynamic MAC Table and configure the static MAC table here.

3 Configuration

Web Interface

To configure MAC Address Table in the web interface:

Aging Configuration

1. Click configuration.
2. Specify the Disable Automatic Aging and Aging Time.
3. Click Save.

MAC Table Learning

1. Click configuration.
2. Specify the Port Members (Auto, Disable, Secure).
3. Click Save.

Static MAC Table Configuration

1. Click configuration and Add new Static entry.
2. Specify the VLAN ID and Mac address, Port Members.
3. Click Save.

Figure 3- 9.1: The MAC Address Table Configuration

MAC Address Table Configuration

Aging Configuration

Disable Automatic Aging

Aging Time seconds

MAC Table Learning

	Port Members																															
	1	2	3	4	5	6	7	8	9	10	11	12	13	14	15	16	17	18	19	20	21	22	23	24	25	26	27	28	29	30	31	32
Auto	<input type="radio"/>	<input type="radio"/>	<input type="radio"/>	<input type="radio"/>	<input type="radio"/>	<input type="radio"/>	<input type="radio"/>	<input type="radio"/>	<input type="radio"/>	<input type="radio"/>	<input type="radio"/>	<input type="radio"/>	<input type="radio"/>	<input type="radio"/>	<input type="radio"/>	<input type="radio"/>	<input type="radio"/>	<input type="radio"/>	<input type="radio"/>	<input type="radio"/>	<input type="radio"/>	<input type="radio"/>	<input type="radio"/>	<input type="radio"/>	<input type="radio"/>	<input type="radio"/>	<input type="radio"/>	<input type="radio"/>	<input type="radio"/>	<input type="radio"/>	<input type="radio"/>	<input type="radio"/>
Disable	<input type="radio"/>	<input type="radio"/>	<input type="radio"/>	<input type="radio"/>	<input type="radio"/>	<input type="radio"/>	<input type="radio"/>	<input type="radio"/>	<input type="radio"/>	<input type="radio"/>	<input type="radio"/>	<input type="radio"/>	<input type="radio"/>	<input type="radio"/>	<input type="radio"/>	<input type="radio"/>	<input type="radio"/>	<input type="radio"/>	<input type="radio"/>	<input type="radio"/>	<input type="radio"/>	<input type="radio"/>	<input type="radio"/>	<input type="radio"/>	<input type="radio"/>	<input type="radio"/>	<input type="radio"/>	<input type="radio"/>	<input type="radio"/>	<input type="radio"/>	<input type="radio"/>	<input type="radio"/>
Secure	<input type="radio"/>	<input type="radio"/>	<input type="radio"/>	<input type="radio"/>	<input type="radio"/>	<input type="radio"/>	<input type="radio"/>	<input type="radio"/>	<input type="radio"/>	<input type="radio"/>	<input type="radio"/>	<input type="radio"/>	<input type="radio"/>	<input type="radio"/>	<input type="radio"/>	<input type="radio"/>	<input type="radio"/>	<input type="radio"/>	<input type="radio"/>	<input type="radio"/>	<input type="radio"/>	<input type="radio"/>	<input type="radio"/>	<input type="radio"/>	<input type="radio"/>	<input type="radio"/>	<input type="radio"/>	<input type="radio"/>	<input type="radio"/>	<input type="radio"/>	<input type="radio"/>	<input type="radio"/>

Static MAC Table Configuration

Delete	VLAN ID	MAC Address	Port Members																															
	1	2	3	4	5	6	7	8	9	10	11	12	13	14	15	16	17	18	19	20	21	22	23	24	25	26	27	28	29	30	31	32		
Delete	1	00-00-00-00-00-00	<input type="checkbox"/>	<input type="checkbox"/>	<input type="checkbox"/>	<input type="checkbox"/>	<input type="checkbox"/>	<input type="checkbox"/>	<input type="checkbox"/>	<input type="checkbox"/>	<input type="checkbox"/>	<input type="checkbox"/>	<input type="checkbox"/>	<input type="checkbox"/>	<input type="checkbox"/>	<input type="checkbox"/>	<input type="checkbox"/>	<input type="checkbox"/>	<input type="checkbox"/>	<input type="checkbox"/>	<input type="checkbox"/>	<input type="checkbox"/>	<input type="checkbox"/>	<input type="checkbox"/>	<input type="checkbox"/>	<input type="checkbox"/>	<input type="checkbox"/>	<input type="checkbox"/>	<input type="checkbox"/>	<input type="checkbox"/>	<input type="checkbox"/>	<input type="checkbox"/>		

Add new static entry

Save Reset

Static MAC Table Configuration

Delete	VLAN ID	MAC Address	Port Members																															
	1	2	3	4	5	6	7	8	9	10	11	12	13	14	15	16	17	18	19	20	21	22	23	24	25	26	27	28	29	30	31	32		
Delete	1	00-00-00-00-00-00	<input type="checkbox"/>	<input type="checkbox"/>	<input type="checkbox"/>	<input type="checkbox"/>	<input type="checkbox"/>	<input type="checkbox"/>	<input type="checkbox"/>	<input type="checkbox"/>	<input type="checkbox"/>	<input type="checkbox"/>	<input type="checkbox"/>	<input type="checkbox"/>	<input type="checkbox"/>	<input type="checkbox"/>	<input type="checkbox"/>	<input type="checkbox"/>	<input type="checkbox"/>	<input type="checkbox"/>	<input type="checkbox"/>	<input type="checkbox"/>	<input type="checkbox"/>	<input type="checkbox"/>	<input type="checkbox"/>	<input type="checkbox"/>	<input type="checkbox"/>	<input type="checkbox"/>	<input type="checkbox"/>	<input type="checkbox"/>	<input type="checkbox"/>	<input type="checkbox"/>		

Add new static entry

Save Reset

Parameter description:

Aging Configuration:

By default, dynamic entries are removed from the MAC table after 300 seconds. This removal is also called aging. Configure aging time by entering a value here in seconds; for example, Age time seconds.

The allowed range is 10 to 1000000 seconds.

Disable the automatic aging of dynamic entries by checking Disable automatic aging.

MAC Table Learning

If the learning mode for a given port is greyed out, another module is in control of the mode, so that it cannot be changed by the user. An example of such a module is the MAC-Based Authentication under 802.1X. Each port can do learning based upon the following settings:

Auto:

Learning is done automatically as soon as a frame with unknown SMAC is received.

Disable:

No learning is done.

Secure:

Only static MAC entries are learned, all other frames are dropped.

 Make sure that the link used for managing the switch is added to the Static Mac Table before changing to secure learning mode, otherwise the management link is lost and can only be restored by using another non-secure port or by connecting to the switch via the serial interface.

Static MAC Table Configuration

The static entries in the MAC table are shown in this table. The static MAC table can contain 64 entries.

The MAC table is sorted first by VLAN ID and then by MAC address.

Delete:

Check to delete the entry. It will be deleted during the next save.

VLAN ID:

The VLAN ID of the entry.

MAC Address:

The MAC address of the entry.

Port Members:

Checkmarks indicate which ports are members of the entry. Check or uncheck as needed to modify the entry.

Adding a New Static Entry:

Click to add a new entry to the static MAC table. Specify the VLAN ID, MAC address, and port members for the new entry. Click "Save".

Buttons:

Save – Click to save changes.

Reset – Click to undo any changes made locally and revert to previously saved values.

3.9.2 Dynamic MAC Table

Entries in the MAC Table are shown on this page. The MAC Table contains up to 8192 entries, and is sorted first by VLAN ID, then by MAC address.

Web Interface

To display MAC Address Table in the web interface:

1. Click Dynamic MAC Table.
2. Specify the VLAN and MAC Address.
3. Display MAC Address Table.

Figure 3- 9.2: The Dynamic MAC Address Table information

3 Configuration

MAC Address Table

Start from VLAN 1 and MAC address 00-00-00-00-00-00 with 20 entries per page.

Auto-refresh Refresh Clear << >>

Type	VLAN	MAC Address	Port Members																																		
			CPU	1	2	3	4	5	6	7	8	9	10	11	12	13	14	15	16	17	18	19	20	21	22	23	24	25	26	27	28	29	30	31	32		
Static	1	00-01-C1-00-00-00	✓																																		
Dynamic	1	00-0D-81-27-3B-F8		✓																																	
Dynamic	1	00-20-8B-5C-52-DB		✓																																	
Dynamic	1	00-24-A8-E0-3C-00		✓																																	
Dynamic	1	00-40-C7-81-8D-82		✓																																	
Dynamic	1	00-40-C7-87-88-02		✓																																	
Dynamic	1	00-40-C7-EF-01-18		✓																																	
Static	1	33-33-00-00-00-01	✓	✓	✓	✓	✓	✓	✓	✓	✓	✓	✓	✓	✓	✓	✓	✓	✓	✓	✓	✓	✓	✓	✓	✓	✓	✓	✓	✓	✓	✓	✓	✓	✓	✓	
Static	1	33-33-00-00-00-02	✓	✓	✓	✓	✓	✓	✓	✓	✓	✓	✓	✓	✓	✓	✓	✓	✓	✓	✓	✓	✓	✓	✓	✓	✓	✓	✓	✓	✓	✓	✓	✓	✓	✓	✓
Static	1	33-33-FF-A8-01-01	✓	✓	✓	✓	✓	✓	✓	✓	✓	✓	✓	✓	✓	✓	✓	✓	✓	✓	✓	✓	✓	✓	✓	✓	✓	✓	✓	✓	✓	✓	✓	✓	✓	✓	✓
Static	1	33-33-FF-AB-C0-E2	✓	✓	✓	✓	✓	✓	✓	✓	✓	✓	✓	✓	✓	✓	✓	✓	✓	✓	✓	✓	✓	✓	✓	✓	✓	✓	✓	✓	✓	✓	✓	✓	✓	✓	✓

Parameter description:

MAC Table Columns

Type:

Indicates whether the entry is a static or a dynamic entry.

VLAN:

The VLAN ID of the entry.

MAC address:

The MAC address of the entry.

Port Members:

The ports that are members of the entry.

Auto-refresh:

Activate the auto-refresh to refresh the information automatically.

Refresh, Clear, <<, >>):

Refresh the MAC address entries manually.

Clear

Press clear to clean up the MAC table.

<<, >>

Go to the previous/next entries of the table.

- ! 00-40-C7-73-01-29: your switch MAC address (for IPv4)
- 33-33-00-00-00-01: Destination MAC (for IPv6 Router Advertisement) (reference IPv6 RA.JPG)
- 33-33-00-00-00-02: Destination MAC (for IPv6 Router Solicitation) (reference IPv6 RS.JPG)
- 33-33-FF-73-01-29: Destination MAC (for IPv6 Neighbor Solicitation) (reference IPv6 DAD.JPG)
- 33-33-FF-A8-01-01: your switch MAC address (for IPv6 global IP)
- FF-FF-FF-FF-FF-FF: for Broadcast.

3.10 VLAN

How to assign a specific VLAN for management purposes. The management VLAN is used to establish an IP connection to the switch from a workstation connected to a port in the VLAN. This connection supports a VSM, SNMP, and Telnet session. By default, the active management VLAN is VLAN 1, but you can designate any VLAN as the management VLAN using the Management VLAN window. Only one management VLAN can be active at a time.

When you specify a new management VLAN, your HTTP connection to the old management VLAN is lost. For this reason, you should have a connection between your management station and a port in the new management VLAN or connect to the new management VLAN through a multi-VLAN route

3.10.1 VLAN Membership

The VLAN membership configuration for the selected switch unit switch can be monitored and modified here. Up to 4096 VLANs are supported. This page allows for adding and deleting VLANs as well as adding and deleting port members of each VLAN.

Web Interface

To configure VLAN membership configuration in the web interface:

1. Click VLAN membership Configuration.
2. Specify Management VLAN ID. 0~ 4094
3. Click Save.

Figure 3-10.1: The VLAN Membership Configuration

Delete	VLAN ID	VLAN Name	1	2	3	4	5	6	7	8	9	10	11	12	13	14	15	16	17	18	19	20	21	22	23	24	25	26	27	28	29	30	31	32
<input type="checkbox"/>	1	default	<input checked="" type="checkbox"/>	<input checked="" type="checkbox"/>	<input checked="" type="checkbox"/>	<input checked="" type="checkbox"/>	<input checked="" type="checkbox"/>	<input checked="" type="checkbox"/>	<input checked="" type="checkbox"/>	<input checked="" type="checkbox"/>	<input checked="" type="checkbox"/>	<input checked="" type="checkbox"/>	<input checked="" type="checkbox"/>	<input checked="" type="checkbox"/>	<input checked="" type="checkbox"/>	<input checked="" type="checkbox"/>	<input checked="" type="checkbox"/>	<input checked="" type="checkbox"/>	<input checked="" type="checkbox"/>	<input checked="" type="checkbox"/>	<input checked="" type="checkbox"/>	<input checked="" type="checkbox"/>	<input checked="" type="checkbox"/>	<input checked="" type="checkbox"/>	<input checked="" type="checkbox"/>	<input checked="" type="checkbox"/>	<input checked="" type="checkbox"/>	<input checked="" type="checkbox"/>	<input checked="" type="checkbox"/>	<input checked="" type="checkbox"/>	<input checked="" type="checkbox"/>	<input checked="" type="checkbox"/>	<input checked="" type="checkbox"/>	

Parameter description:

Delete:

To delete a VLAN entry, check this box. The entry will be deleted on the selected switch. If none of the ports of this switch are members of a VLAN then the delete checkbox will be greyed out (you cannot delete that entry. during the next Save.

VLAN ID:

Indicates the ID of this particular VLAN.

VLAN Name:

Indicates the name of VLAN. VLAN Name can only contain alphabets or numbers. VLAN name should contain at least one alphabet. VLAN name can be edited for the existing VLAN entries or it can be added to the new entries.

Port Members:

A row of check boxes for each port is displayed for each VLAN ID. To include a port in a VLAN, check the box. To remove or exclude the port from the VLAN, make sure the box is unchecked. By default, no ports are members, and all boxes are unchecked.

Adding a New VLAN:

Click to add a new VLAN ID. An empty row is added to the table, and the VLAN can be configured as needed. Legal values for a VLAN ID are 1 through 4095.

3 Configuration

The VLAN is enabled on the selected switch unit when you click on "Save". The VLAN is thereafter present on the other switch units, but with no port members. The check box is greyed out when VLAN is displayed on other switches, but user can add member ports to it.

A VLAN without any port members on any unit will be deleted when you click "Save".

The button can be used to undo the addition of new VLANs.

Buttons:

Save:

Click to save changes.

Reset:

Click to undo any changes made locally and revert to previously saved values.

Refresh:

Refresh the VLAN entries manually.

Clear:

Clean up the VLAN table.

|<<, >>:

Go to the previous/next page of the table.

3.10.2 Ports

In the VLAN Tag Rule Settings, VID number for each port can be set. The range of VID numbers is from 1 to 4094. Ingress filtering rules for each port are available. There are two ingress filtering rules which can be applied to the switch. The Ingress Filtering Rule 1 is "forward only packets with VID matching this port's configured VID". The Ingress Filtering Rule 2 is "drop untagged frame". You can also select the Role of each port as Access, Trunk, or Hybrid.

Web Interface

To configure VLAN Port configuration in the web interface:

1. Click VLAN Port Configuration.
2. Specify the VLAN Port Configuration parameters.
3. Click Save.

Figure 3-10.2: The VLAN Port Configuration

Port	Port Type	Ingress Filtering	Frame Type	Egress Rule	PVID
*	<>	<input type="checkbox"/>	<>	<>	1
1	Unaware	<input type="checkbox"/>	All	Hybrid	1
2	Unaware	<input type="checkbox"/>	All	Hybrid	1
3	Unaware	<input type="checkbox"/>	All	Hybrid	1
50	Unaware	<input type="checkbox"/>	All	Hybrid	1
51	Unaware	<input type="checkbox"/>	All	Hybrid	1
52	Unaware	<input type="checkbox"/>	All	Hybrid	1

Save Reset

Parameter description:

Ethertype for Custom S-ports:

This field specifies the ether type used for Custom S-ports. This is a global setting for all the Custom S-ports. Custom Ethertype enables the user to change the Ethertype value on a port to any value to support network devices that do not use the standard 0x8100 Ethertype field value on 802.1Q-tagged or 802.1p-tagged frames.

Port:

This is the logical port number of this row.

Port Type:

Port can be one of the following types: Unaware, Customer port(C-port), Service port(S-port), Custom Service port(S-custom-port)

If Port Type is Unaware, all frames are classified to the Port VLAN ID and tags are not removed.

Ingress Filtering:

Enable ingress filtering on a port by checking the box. This parameter affects VLAN ingress processing. If ingress filtering is enabled and the ingress port is not a member of the classified VLAN of the frame, the frame is discarded. By default, ingress filtering is disabled (no checkmark).

Frame Type:

Determines whether the port accepts all frames or only tagged/untagged frames. This parameter affects VLAN ingress processing. If the port only accepts tagged frames, untagged frames received on the port are discarded. By default, the field is set to All.

Port VLAN Mode:

Configures the Port VLAN Mode. The allowed values are None or Specific. This parameter affects VLAN ingress and egress processing.

If None is selected, a VLAN tag with the classified VLAN ID is inserted in frames transmitted on the port. This mode is normally used for ports connected to VLAN aware switches.

If Specific (the default value) is selected, a Port VLAN ID can be configured (see below). Untagged frames received on the port are classified to the Port VLAN ID. If VLAN awareness is disabled, all frames received on the port are classified to the Port VLAN ID. If the classified VLAN ID of a frame transmitted on the port is different from the Port VLAN ID, a VLAN tag with the classified VLAN ID is inserted in the frame.

Port VLAN ID:

Configures the VLAN identifier for the port. The allowed values are 1 through 4095. The default value is 1.



The port must be a member of the same VLAN as the Port VLAN ID.

Buttons:

Save – Click to save changes.

Reset – Click to undo any changes made locally and revert to previously saved values.

3.10.3 Switch Status

The Switch Status gathers the information of all VLAN status and reports it by the order of Static NAS MVRP MVP Voice VLAN MSTP GVRP Combined.

Web Interface

To display VLAN membership status in the web interface:

1. Click VLAN membership.
2. Specify the Static NAS MVRP MVP Voice VLAN MSTP GVRP Combined.

3. Display membership information.

Figure 3-10.3: The VLAN Membership Status for Combined users

The ports belong to the currently selected stack unit, as reflected by the page header.

VLAN ID	1	2	3	4	5	6	7	8	9	10	11	12	13	14	15	16	17	18	19	20	21	22	23	24	25	26	27	28	29	30	31	32
1	<input checked="" type="checkbox"/>	<input checked="" type="checkbox"/>	<input checked="" type="checkbox"/>	<input checked="" type="checkbox"/>	<input checked="" type="checkbox"/>	<input checked="" type="checkbox"/>	<input checked="" type="checkbox"/>	<input checked="" type="checkbox"/>	<input checked="" type="checkbox"/>	<input checked="" type="checkbox"/>	<input checked="" type="checkbox"/>	<input checked="" type="checkbox"/>	<input checked="" type="checkbox"/>	<input checked="" type="checkbox"/>	<input checked="" type="checkbox"/>	<input checked="" type="checkbox"/>	<input checked="" type="checkbox"/>	<input checked="" type="checkbox"/>	<input checked="" type="checkbox"/>	<input checked="" type="checkbox"/>	<input checked="" type="checkbox"/>	<input checked="" type="checkbox"/>	<input checked="" type="checkbox"/>	<input checked="" type="checkbox"/>	<input checked="" type="checkbox"/>	<input checked="" type="checkbox"/>	<input checked="" type="checkbox"/>	<input checked="" type="checkbox"/>	<input checked="" type="checkbox"/>	<input checked="" type="checkbox"/>		

Parameter description:

VLAN USER (You can scroll to select one kind VLAN user as below)

VLAN User module uses services of the VLAN management functionality to configure VLAN memberships and VLAN port configurations such as PVID and UVID. Currently we support the following VLAN user types:

Web/SNMP: These are referred to as static.

NAS: NAS provides port-based authentication, which involves communications between a Supplicant, Authenticator, and an Authentication Server.

MVRP: Multiple VLAN Registration Protocol (MVRP) allows dynamic registration and deregistration of VLANs on ports on a VLAN bridged network.

GVRP: GARP VLAN Registration Protocol (GVRP) allows dynamic registration and deregistration of VLANs on ports on a VLAN bridged network.

Voice VLAN: Voice VLAN is a VLAN configured specially for voice traffic typically originating from IP phones.

MVR: MVR is used to eliminate the need to duplicate multicast traffic for subscribers in each VLAN. Multicast traffic for all channels is sent only on a single (multicast) VLAN.

MSTP: The 802.1s Multiple Spanning Tree protocol (MSTP) uses VLANs to create multiple spanning trees in a network, which significantly improves network resource utilization while maintaining a loop-free environment.

VLAN ID:

Indicates the ID of this particular VLAN.

VLAN Membership:

The VLAN Membership Status Page shall show the current VLAN port members for all VLANs configured by a selected VLAN User (selection shall be allowed by a Combo Box). When ALL VLAN Users are selected, it shall show this information for all the VLAN Users, and this is by default. VLAN membership allows the frames classified to the VLAN ID to be forwarded on the respective VLAN member ports.

Auto-refresh:

Activate the auto-refresh to refresh the information automatically.

Refresh:

Refresh the VLAN entries manually.

3.10.4 Port Status

The Port Status gathers the information of all VLAN status and reports it by the order of Static NAS MVRP MVP Voice VLAN MSTP GVRP Combined.

Web Interface

To display VLAN Port Status in the web interfaces:

1. Click VLAN Port Status.

2. Specify the Static NAS MVRP MVP Voice VLAN MSTP GVRP Combined.

3. Display Port Status information.

Figure 3-10.4: The VLAN Port Status for Static user

Port	PVID	Port Type	Ingress Filtering	Frame Type	Tx Tag	UVID	Conflicts
1	1	UnAware	Disabled	All	Untag_this	1	No
2	1	UnAware	Disabled	All	Untag_this	1	No
3	1	UnAware	Disabled	All	Untag_this	1	No
4	1	UnAware	Disabled	All	Untag_this	1	No

Parameter description:

Port:

The logical port for the settings contained in the same row.

PVID:

Shows the VLAN identifier for that port. The allowed values are 1 through 4095. The default value is 1.

Port Type:

Shows the Port Type. Port type can be any of Unaware, C-port, S-port, Custom S-port.

If Port Type is Unaware, all frames are classified to the Port VLAN ID and tags are not removed. C-port is Customer Port. S-port is Service port. Custom S-port is S-port with Custom TPID.

Ingress Filtering:

Shows the ingress filtering on a port. This parameter affects VLAN ingress processing. If ingress filtering is enabled and the ingress port is not a member of the classified VLAN, the frame is discarded.

Frame Type:

Shows whether the port accepts all frames or only tagged frames. This parameter affects VLAN ingress processing. If the port only accepts tagged frames, untagged frames received on that port are discarded.

Tx Tag:

Shows egress filtering frame status whether tagged or untagged.

UVID:

Shows UVID (untagged VLAN ID). Port's UVID determines the packet's behavior at the egress side.

Conflicts:

Shows status of Conflicts whether exists or not. When a Volatile VLAN User requests to set VLAN membership or VLAN port configuration, the following conflicts can occur:

Functional Conflicts between features.

Conflicts due to hardware limitation.

Direct conflict between user modules.

Auto-refresh:

Activate the auto-refresh to refresh the information automatically.

Refresh:

Refresh the VLAN Port Status information manually.

3.10.5 Private VLANs

In a private VLAN, communication between ports in that private VLAN is not permitted. Any VLAN can be configured as a private VLAN.

Private VLAN Membership

The Private VLAN membership configurations for the switch can be monitored and modified here. Private VLANs can be added or deleted here. Port members of each Private VLAN can be added or removed here.

Private VLANs are based on the source port mask, and there are no connections to VLANs. This means that VLAN IDs and Private VLAN IDs can be identical.

A port must be a member of both a VLAN and a Private VLAN to be able to forward packets. By default, all ports are VLAN unaware and members of VLAN 1 and Private VLAN 1.

A VLAN unaware port can only be a member of one VLAN, but it can be a member of multiple Private VLANs.

Web Interface

To configure Private VLAN in the web interface:

1. Click add new Private VLAN configuration.
2. Specify the Private VLAN ID and Port Members.
3. Click Save.

Figure 3-10.5.1: The Port Isolation Configuration

Private VLAN Membership Configuration		Port Members																									
Delete	PVLAN ID	1	2	3	4	5	6	7	8	9	10	11	12	13	14	15	16	17	18	19	20	21	22	23	24	25	26
<input type="checkbox"/>	1	<input checked="" type="checkbox"/>	<input checked="" type="checkbox"/>	<input checked="" type="checkbox"/>	<input checked="" type="checkbox"/>	<input checked="" type="checkbox"/>	<input checked="" type="checkbox"/>	<input checked="" type="checkbox"/>	<input checked="" type="checkbox"/>	<input checked="" type="checkbox"/>	<input checked="" type="checkbox"/>	<input checked="" type="checkbox"/>	<input checked="" type="checkbox"/>	<input checked="" type="checkbox"/>	<input checked="" type="checkbox"/>	<input checked="" type="checkbox"/>	<input checked="" type="checkbox"/>	<input checked="" type="checkbox"/>	<input checked="" type="checkbox"/>	<input checked="" type="checkbox"/>	<input checked="" type="checkbox"/>	<input checked="" type="checkbox"/>	<input checked="" type="checkbox"/>	<input checked="" type="checkbox"/>	<input checked="" type="checkbox"/>	<input checked="" type="checkbox"/>	<input checked="" type="checkbox"/>

Add New Private VLAN

Apply Reset

Parameter description:

Delete:

Check to delete a private VLAN entry. The entry will be deleted during the next save.

Private VLAN ID

The ID of this particular private VLAN.

Port Members

A row of check boxes for each port is displayed for each private VLAN ID. To include a port in a Private VLAN, check the box. To remove or exclude the port from the Private VLAN, make sure the box is unchecked.

Adding a New Private VLAN

Click to add a new private VLAN ID. An empty row is added to the table, and the private VLAN can be configured as needed. The allowed range for a private VLAN ID is the same as the switch port number range. Any values outside this range are not accepted, and a warning message appears. Click "OK" to discard the incorrect entry, or click "Cancel" to return to the editing and make a correction.

The Private VLAN is enabled when you click "Save".

Port Isolation

Port Isolation provides for an apparatus and method to isolate ports on layer 2 switches on the same VLAN to restrict traffic flow. The apparatus comprises a switch having said plurality of ports, each port configured as a protected port or

a non-protected port. An address table memory stores an address table having a destination address and port number pair. A forwarding map generator generates a forwarding map which is responsive to a destination address of a data packet. The method for isolating ports on a layer 2 switch comprises configuring each of the ports on the layer 2 switch as a protected port or a non-protected port. A destination address on an data packet is matched with a physical address on said layer 2 switch and a forwarding map is generated for the data packet based upon the destination address on the data packet. The data packet is then sent to the plurality of ports pursuant to the forwarding map generated based upon whether the ingress port was configured as a protected or non-protected port.

This page is used for enabling or disabling port isolation on ports in a Private VLAN. A port member of a VLAN can be isolated to other isolated ports on the same VLAN and Private VLAN.

Web Interface

To configure Port Isolation configuration in the web interface:

1. Click VLAN, Port Isolation.
2. Activate which port want to enable Port Isolation
3. Click Save.

Figure 3-10.5.1: The Port Isolation Configuration

Port Isolation Configuration																																
																															Port Number	
1	2	3	4	5	6	7	8	9	10	11	12	13	14	15	16	17	18	19	20	21	22	23	24	25	26	27	28	29	30	31	32	
<input type="checkbox"/>	<input type="checkbox"/>	<input type="checkbox"/>	<input type="checkbox"/>	<input type="checkbox"/>	<input type="checkbox"/>	<input type="checkbox"/>	<input type="checkbox"/>	<input type="checkbox"/>	<input type="checkbox"/>	<input type="checkbox"/>	<input type="checkbox"/>	<input type="checkbox"/>	<input type="checkbox"/>	<input type="checkbox"/>	<input type="checkbox"/>	<input type="checkbox"/>	<input type="checkbox"/>	<input type="checkbox"/>	<input type="checkbox"/>	<input type="checkbox"/>	<input type="checkbox"/>	<input type="checkbox"/>	<input type="checkbox"/>	<input type="checkbox"/>	<input type="checkbox"/>	<input type="checkbox"/>	<input type="checkbox"/>	<input type="checkbox"/>	<input type="checkbox"/>	<input type="checkbox"/>	<input type="checkbox"/>	<input type="checkbox"/>
<input type="button" value="Save"/>																<input type="button" value="Reset"/>																

Parameter description:

Port Members:

A check box is provided for each port of a private VLAN. When checked, port isolation is enabled on that port. When unchecked, port isolation is disabled on that port. By default, port isolation is disabled on all ports.

Buttons:

Save – Click to save changes.

Reset – Click to undo any changes made locally and revert to previously saved values.

3.10.6 MAC-based VLAN

MAC address-based VLAN decides the VLAN for forwarding an untagged frame based on the source MAC address of the frame.

The most common way of grouping VLAN members is by port, hence the name port-based VLAN. Typically, the device adds the same VLAN tag to untagged packets that are received through the same port. Later on, these packets can be forwarded in the same VLAN. Port-based VLAN is easy to configure, and applies to networks where the locations of terminal devices are relatively fixed. As mobile office and wireless network access gain more popularity, the ports that terminal devices use to access the networks are very often non-fixed. A device may access a network through Port A this time, but through Port B the next time. If Port A and Port B belong to different VLANs, the device will be assigned to a different VLAN the next time it accesses the network. As a result, it will not be able to use the resources in the old VLAN. On the other hand, if Port A and Port B belong to the same VLAN, after terminal devices access the network through Port B, they will have access to the same resources as those accessing the network through Port A do, which brings security issues. To provide user access and ensure data security in the mean time, the MAC-based VLAN technology is developed.

MAC-based VLANs group VLAN members by MAC address. With MAC-based VLAN configured, the device adds a VLAN tag to an untagged frame according to its source MAC address. MAC-based VLANs are mostly used in conjunction with security technologies such as 802.1X to provide secure, flexible network access for terminal devices.

3 Configuration

Configuration

The MAC-based VLAN entries can be configured here. This page allows for adding and deleting MAC-based VLAN entries and assigning the entries to different ports. This page shows only static entries.

Web Interface

To configure MAC address-based VLAN configuration in the web interface:

1. Click MAC address-based VLAN configuration and add new entry.
2. Specify the MAC address and VLAN ID.
3. Click Save.

Figure 3-10.6.1: The MAC-based VLAN Membership Configuration



Parameter description:

Delete:

To delete a MAC-based VLAN entry, check this box and press save. The entry will be deleted on the selected switch.

MAC Address:

Indicates the MAC address.

VLAN ID:

Indicates the VLAN ID.

Port Members:

A row of check boxes for each port is displayed for each MAC-based VLAN entry. To include a port in a MAC-based VLAN, check the box. To remove or exclude the port from the MAC-based VLAN, make sure the box is unchecked. By default, no ports are members, and all boxes are unchecked.

Adding a New MAC-based VLAN

Click to add a new MAC-based VLAN entry. An empty row is added to the table, and the MAC-based VLAN entry can be configured as needed. Any unicast MAC address can be configured for the MAC-based VLAN entry. No broadcast or multicast MAC addresses are allowed. Legal values for a VLAN ID are 1 through 4095.

The MAC-based VLAN entry is enabled on the selected switch unit when you click on "Save". A MAC-based VLAN without any port members on any unit will be deleted when you click "Save".

The button can be used to undo the addition of new MAC-based VLANs.

Buttons:

Save – Click to save changes.

Reset – Click to undo any changes made locally and revert to previously saved values.

Status

This section shows MAC-based VLAN entries configured by various MAC-based VLAN users. Currently we support following VLAN User types:

NAS: NAS provides port-based authentication, which involves communications between a Supplicant, Authenticator, and an Authentication Server.

Web Interface

To display MAC-based VLAN configured in the web interface:

1. Click MAC-based VLAN Status.
2. Specify the Staic NAS Combined.
3. Display MAC-based information.

Figure 3-10.6.2: The MAC-based VLAN Membership Status for User Static

MAC-based VLAN Membership Configuration for User Static		Static		Auto-refresh <input type="checkbox"/>		Refresh																																		
MAC Address	VLAN ID	Port Members																																						
		1	2	3	4	5	6	7	8	9	10	11	12	13	14	15	16	17	18	19	20	21	22	23	24	25	26	27	28	29	30	31	32	33	34	35	36	37	38	39
No data exists for the user																																								

Parameter description:

MAC Address:

Indicates the MAC address.

VLAN ID:

Indicates the VLAN ID.

Port Members:

Port members of the MAC-based VLAN entry.

Auto-refresh:

Activate the auto-refresh to refresh the information automatically.

Refresh:

Refresh the MAC-based VLAN Membership information manually.

3.10.7 Protocol-based VLAN

This section describe Protocol-based VLAN. The Switch supports protocols including Ethernet, LLC, and SNAP.

LLC

The Logical Link Control (LLC) data communication protocol layer is the upper sub-layer of the Data Link Layer (which is itself layer 2, just above the Physical Layer) in the seven-layer OSI reference model. It provides multiplexing mechanisms that make it possible for several network protocols (IP, IPX, Decnet and Appletalk) to coexist within a multipoint network and to be transported over the same network media, and can also provide flow control and automatic repeat request (ARQ) error management mechanisms.

SNAP

The Sub-network Access Protocol (SNAP) is a mechanism for multiplexing, on networks using IEEE 802.2 LLC, more protocols than can be distinguished by the 8-bit 802.2 Service Access Point (SAP) fields. SNAP supports identifying protocols by Ethernet type field values; it also supports vendor-private protocol identifier spaces. It is used with IEEE 802.3, IEEE 802.4, IEEE 802.5, IEEE 802.11 and other IEEE 802 physical network layers, as well as with non-IEEE 802 physical network layers such as FDDI that use 802.2 LLC.

Protocol to Group

This page allows you to add new protocols to Group Name (unique for each Group) mapping entries as well as allow you to see and delete already mapped entries for the selected switch.

Web Interface

3 Configuration

To configure Protocol -based VLAN configuration in the web interface:

1. Click Protocol -based VLAN configuration and add new entry.
2. Specify the Ethernet LLC SNAP Protocol and Group Name.
3. Click Save.

Figure 3-10.7.1: The Protocol to Group Mapping Table

The figure consists of two screenshots of the 'Protocol to Group Mapping Table' web interface. The top screenshot shows an empty table with a 'No Group entry found!' message. The bottom screenshot shows a table with one entry: 'Ethernet' with 'Etype: 0x0800' and an empty 'Group Name' field.

Delete	Frame Type	Value	Group Name
No Group entry found!			
Add new entry			
Save Reset			

Delete	Frame Type	Value	Group Name
Delete	Ethernet	Etype: 0x0800	
Add new entry			
Save Reset			

Parameter description:

Delete:

To delete a Protocol to Group Name map entry, check this box. The entry will be deleted on the switch during the next Save.

Frame Type:

Frame Type can have one of the following values:

Ethernet

LLC

SNAP

 On changing the Frame type field, valid value of the following text field will vary depending on the new frame type you selected.

Value:

Valid value that can be entered in this text field depends on the option selected from the preceding Frame Type selection menu.

Below are the criteria for three different Frame Types:

For Ethernet: Values in the text field when Ethernet is selected as a Frame Type is called etype. Valid values for etype ranges from 0x0600-0xffff

For LLC: Valid value in this case is comprised of two different sub-values. a. DSAP: 1-byte long string (0x00-0xff) b. SSAP: 1-byte long string (0x00-0xff)

For SNAP: Valid value in this case also is comprised of two different sub-values. a. OUI: OUI (Organizationally Unique Identifier) is value in format of xx-xx-xx where each pair (xx) in string is a hexadecimal value ranges from 0x00-0xff. b. PID: If the OUI is hexadecimal 000000, the protocol ID is the Ethernet type (EtherType) field value for the protocol running on top of SNAP; if the OUI is an OUI for a particular organization, the protocol ID is a value assigned by that organization

to the protocol running on top of SNAP. In other words, if value of OUI field is 00-00-00 then value of PID will be etype (0x0600-0xffff) and if value of OUI is other than 00-00-00 then valid value of PID will be any value from 0x0000 to 0xffff.

Group Name:

A valid Group Name is a unique 16-character long string for every entry which consists of a combination of alphabets (a-z or A-Z) and integers (0-9).

 Special character and underscore(_) are not allowed.

Adding a New Group to VLAN mapping entry:

Click to add a new entry in mapping table. An empty row is added to the table; Frame Type, Value and the Group Name can be configured as needed.

The button can be used to undo the addition of new entry.

Save:

Click to save changes.

Reset:

Click to undo any changes made locally and revert to previously saved values.

Refresh:

Refresh the Protocol Group Mapping information manually.

Group to VLAN

This section allows you to map an already configured Group Name to a VLAN for the selected switch.

Web Interface

To display Group Name to VLAN mapping table configured in the web interface:

1. Click Group Name VLAN configuration and add new entry.
2. Specify the Group Name and VLAN ID.
3. Click Save.

Figure 3-12.7.2: The Group Name of VLAN Mapping Table

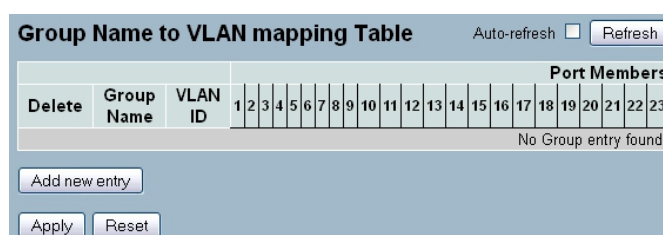

Group Name to VLAN mapping Table Auto-refresh Refresh

Delete	Group Name	VLAN ID	Port Members																						
			1	2	3	4	5	6	7	8	9	10	11	12	13	14	15	16	17	18	19	20	21	22	23
No Group entry found!																									

Add new entry

Apply Reset

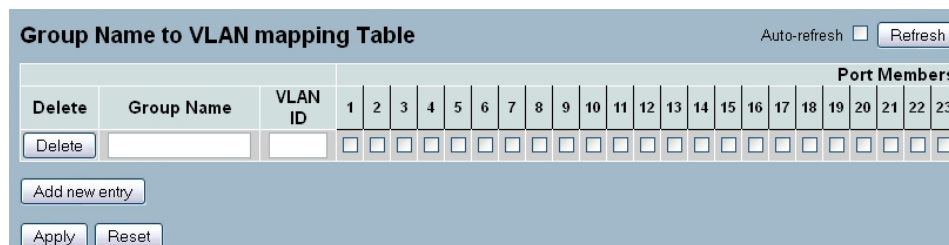

Group Name to VLAN mapping Table Auto-refresh Refresh

Delete	Group Name	VLAN ID	Port Members																						
			1	2	3	4	5	6	7	8	9	10	11	12	13	14	15	16	17	18	19	20	21	22	23
Delete			<input type="checkbox"/>	<input type="checkbox"/>	<input type="checkbox"/>	<input type="checkbox"/>	<input type="checkbox"/>	<input type="checkbox"/>	<input type="checkbox"/>	<input type="checkbox"/>	<input type="checkbox"/>	<input type="checkbox"/>	<input type="checkbox"/>	<input type="checkbox"/>	<input type="checkbox"/>	<input type="checkbox"/>	<input type="checkbox"/>	<input type="checkbox"/>	<input type="checkbox"/>	<input type="checkbox"/>	<input type="checkbox"/>	<input type="checkbox"/>	<input type="checkbox"/>	<input type="checkbox"/>	<input type="checkbox"/>

Add new entry

Apply Reset

Parameter description:

Delete:

To delete a Group Name to VLAN map entry, check this box. The entry will be deleted on the switch during the next Save Group Name:

A valid Group Name is a string of at most 16 characters which consists of a combination of alphabets (a-z or A-Z) and integers(0-9), no special character is allowed. whichever Group name you try map to a VLAN must be present in Protocol to Group mapping table and must not be used by any other existing mapping entry on this page.

VLAN ID:

Indicates the ID to which Group Name will be mapped. A valid VLAN ID ranges from 1-4095.

Port Members:

A row of check boxes for each port is displayed for each Group Name to VLAN ID mapping. To include a port in a mapping, check the box. To remove or exclude the port from the mapping, make sure the box is unchecked. By default, no ports are members, and all boxes are unchecked.

Adding a New Group to VLAN mapping entry:

Click to add a new entry in mapping table. An empty row is added to the table, the Group Name, VLAN ID and port members can be configured as needed. Legal values for a VLAN ID are 1 through 4095. The button can be used to undo the addition of new entry.

Buttons:

Save:

Click to save changes.

Reset:

Click to undo any changes made locally and revert to previously saved values.

Auto-refresh:

Activate the auto-refresh to refresh the information automatically.

Refresh:

Refresh the Protocol Group Mapping information manually.

3.11 Voice VLAN

Voice VLAN is VLAN configured specially for voice traffic. By adding the ports with voice devices attached to voice VLAN, you can perform QoS-related configuration for voice data, ensuring the transmission priority of voice traffic and voice quality.

3.11.1 Configuration

The Voice VLAN feature enables voice traffic forwarding on the Voice VLAN, then the switch can classify and schedule network traffic. It is recommended that there be two VLANs on a port - one for voice, one for data. Before connecting the IP device to the switch, the IP phone should configure the voice VLAN ID correctly. It should be configured through its own GUI.

Web Interface

To configure Voice VLAN in the web interface:

1. Select "Enabled" in the Voice VLAN Configuration.
2. Specify VLAN ID, Aging Time, and Traffic Class.
4. Specify (Port Mode, Security, Discovery Protocol) in the Port Configuration

5. Click Save.

Figure 3-11.1: The Voice VLAN Configuration

Voice VLAN Configuration

Mode	Disabled
VLAN ID	1000
Aging Time	86400 seconds
Traffic Class	7 (High)

Port Configuration

Port	Mode	Security	Discovery Protocol
*	<>	<>	<>
1	Disabled	Disabled	OUI
2	Disabled	Disabled	OUI
3	Disabled	Disabled	OUI
4	Disabled	Disabled	OUI
49	Disabled	Disabled	OUI
50	Disabled	Disabled	OUI
51	Disabled	Disabled	OUI
52	Disabled	Disabled	OUI

Apply Reset

Parameter description:

Mode:

Indicates the Voice VLAN mode operation. We must disable MSTP feature before we enable Voice VLAN. It can avoid the conflict of ingress filtering. Possible modes are:

Enabled: Enable Voice VLAN mode operation.

Disabled: Disable Voice VLAN mode operation.

VLAN ID:

Indicates the Voice VLAN ID. It should be a unique VLAN ID in the system and cannot equal each port PVID. It is a conflict in configuration if the value equals management VID, MVR VID, PVID etc. The allowed range is 1 to 4095.

Aging Time:

Indicates the Voice VLAN secure learning aging time. The allowed range is 10 to 10000000 seconds. It is used when security mode or auto detect mode is enabled. In other cases, it will be based on hardware aging time. The actual aging time will be situated between the [age_time; 2 * age_time] interval.

Traffic Class:

Indicates the Voice VLAN traffic class. All traffic on the Voice VLAN will apply this class.

Port Mode:

Indicates the Voice VLAN port mode.

When the port mode isn't equal disabled, we must disable MSTP feature before we enable Voice VLAN. It can avoid the conflict of ingress filtering.

Possible port modes are:

Disabled: Disjoin from Voice VLAN.

Auto: Enable auto detect mode. It detects whether there is VoIP phone attached to the specific port and configures the Voice VLAN members automatically.

Forced: Force join to Voice VLAN.

Port Security:

3 Configuration

Indicates the Voice VLAN port security mode. When the function is enabled, all non-telephonic MAC addresses in the Voice VLAN will be blocked for 10 seconds. Possible port modes are:

Enabled: Enable Voice VLAN security mode operation.

Disabled: Disable Voice VLAN security mode operation.

Port Discovery Protocol:

Indicates the Voice VLAN port discovery protocol. It will only work when auto detect mode is enabled. We should enable LLDP feature before configuring discovery protocol to "LLDP" or "Both". Changing the discovery protocol to "OUI" or "LLDP" will restart auto detect process. Possible discovery protocols are:

OUI: Detect telephony device by OUI address.

LLDP: Detect telephony device by LLDP.

Both: Both OUI and LLDP.

Buttons:

Save – Click to save changes.

Reset – Click to undo any changes made locally and revert to previously saved values.

3.11.2 OUI

This section describes how to configure the Voice VLAN OUI table. The maximum entry number is 16. Modifying the OUI table will restart auto detection of the OUI process.

Web Interface

To configure Voice VLAN OUI Table in the web interface:

1. Select "Add new entry", "Delete „in the Voice VLAN OUI table.
2. Specify Telephony OUI, Description.
3. Click Save.

Figure 3-11.2: The Voice VLAN OUI Table

Voice VLAN OUI Table		
Delete	Telephony OUI	Description
<input type="checkbox"/>	00-01-e3	Siemens AG phones
<input type="checkbox"/>	00-03-6b	Cisco phones
<input type="checkbox"/>	00-0f-e2	H3C phones
<input type="checkbox"/>	00-60-b9	Philips and NEC AG phones
<input type="checkbox"/>	00-d0-1e	Pingtel phones
<input type="checkbox"/>	00-e0-75	Polycom phones
<input type="checkbox"/>	00-e0-bb	3Com phones

Add new entry

Save Reset

Parameter description:

Delete:

Check to delete the entry. It will be deleted during the next save.

Telephony OUI:

A telephony OUI address is a globally unique identifier assigned to a vendor by IEEE. It must be 6 characters long and the input format is "xx-xx-xx" (x is a hexadecimal digit).

Description:

The description of OUI address. Normally, it describes which vendor telephony device it belongs to. The allowed string length is 0 to 32.

Add New entry:

Click to add a new entry in Voice VLAN OUI table. An empty row is added to the table, the Telephony OUI, Description.

Buttons:

Save – Click to save changes.

Reset – Click to undo any changes made locally and revert to previously saved values.

 All non-telephonic MAC addresses in the Voice VLAN will be blocked for 10 seconds.

3.12 GARP

The Generic Attribute Registration Protocol (GARP) provides a generic framework whereby devices in a bridged LAN, e.g. end stations and switches, can register and de-register attribute values, such as VLAN Identifiers, with each other. In doing so, the attributes are propagated to devices in the bridged LAN, and these devices form a "reachability"-tree that is a subset of an active topology. GARP defines the architecture, rules of operation, state machines and variables for the registration and de-registration of attribute values.

A GARP participation in a switch or an end station consists of a GARP application component, and a GARP Information Declaration (GID) component associated with each port or the switch. The propagation of information between GARP participants for the same application in a bridge is carried out by the GARP Information Propagation (GIP) component. Protocol exchanges take place between GARP participants by means of LLC Type 1 services, using the group MAC address and PDU format defined for the GARP application concerned.

3.12.1 Configuration

This page allows you to configure the basic GARP Configuration settings for all switch ports. The settings relate to the currently selected unit, as reflected by the page header.

Web Interface

To configure GARP Port in the web interface:

1. Click GARP configure.
2. Specify GARP Configuration Parameters.
3. Click Save.

Figure 3-12.1: The GARP Port Configuration

GARP Port Configuration Auto-refresh

Port	Timer Values			Application	Attribute Type	GARP Applicant
	Join Timer	Leave Timer	Leave All Timer			
1	<input type="text" value="200"/>	<input type="text" value="600"/>	<input type="text" value="10000"/>	GVRP ▾	VLAN ▾	normal-participant ▾
2	<input type="text" value="200"/>	<input type="text" value="600"/>	<input type="text" value="10000"/>	GVRP ▾	VLAN ▾	normal-participant ▾
3	<input type="text" value="200"/>	<input type="text" value="600"/>	<input type="text" value="10000"/>	GVRP ▾	VLAN ▾	normal-participant ▾
50	<input type="text" value="200"/>	<input type="text" value="600"/>	<input type="text" value="10000"/>	GVRP ▾	VLAN ▾	normal-participant ▾
51	<input type="text" value="200"/>	<input type="text" value="600"/>	<input type="text" value="10000"/>	GVRP ▾	VLAN ▾	normal-participant ▾
52	<input type="text" value="200"/>	<input type="text" value="600"/>	<input type="text" value="10000"/>	GVRP ▾	VLAN ▾	normal-participant ▾

Parameter description:

Port:

The Port column shows the list of ports for which you can configure GARP settings. There are 2 types configuration settings which can be configured on per port bases.

Timer Values

Application

Attribute Type

GARP Applicant

Timer Values:

Three different timers can be configured on this page:

Join Timer: The default value for Join timer is 200ms.

Leave Timer: The range of values for Leave Time is 600-1000ms. The default value for Leave Timer is 600ms.

Leave All Timer: The default value for Leave All Timer is 10000ms

Application:

Currently supported applications:GVRP.

Attribute Type:

Currently supported Attribute Type is VLAN.

GARP Applicant

This configuration is used to configure the Applicant state machine behavior for GARP on a particular port locally.

normal-participant: In this mode the Applicant state machine will operate normally in GARP protocol exchanges.

non-participant: In this mode the Applicant state machine will not participate in the protocol operation.

The default configuration is normal participant.

Buttons:

Save – Click to save changes.

Reset – Click to undo any changes made locally and revert to previously saved values.

3.12.2 Statistics

This section describes the port statistics of GARP for all switch ports. The port statistics relate to the currently selected unit, as reflected by the page header.

Web Interface

To display GARP Port statistics in the web interface:

1. Click GARP statistics.
2. Click Refresh to refresh the GARP statistics information.

Figure 3-12.2: The GARP Port Statistics



Port	Peer MAC	Failed Count
1	--	--
2	--	--
3	--	--

Parameter description:

Port:

The Port column shows the list of all ports for which GARP statistics are available.

Peer MAC:

The Peer MAC is the MAC address of the neighbor Switch from which the GARP frame is received.

Failed Count:

The number of times attempted GARP registrations could not be completed

Auto-refresh:

Activate the auto-refresh to refresh the information automatically.

Refresh:

Refresh the GARP Port Statistics information manually.

3.13 GVRP

GVRP is an application based on Generic Attribute Registration Protocol (GARP), mainly used to automatically and dynamically maintain the group membership information of the VLANs. The GVRP offers the function providing the VLAN registration service through a GARP application. It makes use of GARP Information Declaration (GID) to maintain the ports associated with their attribute database and GARP Information Propagation (GIP) to communicate among switches and end stations. With GID information and GIP, GVRP state machine maintain the contents of Dynamic VLAN Registration Entries for each VLAN and propagate these information to other GVRP-aware devices to setup and update their knowledge database, the set of VLANs associated with currently active members, and through which ports these members can be reached.

3.13.1 Configuration

This page allows you to configure the basic GVRP Configuration settings for all switch ports. The settings relate to the currently selected unit, as reflected by the page header.

Web Interface

To configure GVRP Port in the web interface:

1. Click GVRP configure.
2. Specify GVRP Configuration Parameters.
3. Click Save.

Figure 3-13.1: The GVRP Global Configuration

Port	GVRP Mode	GVRP rrole
1	Disable	Disable
2	Disable	Disable
3	Disable	Disable
50	Disable	Disable
51	Disable	Disable
52	Disable	Disable

Parameter description:

GVRP Mode:

GVRP Mode is a global setting, to enable the GVRP globally select 'Enable' from menu and to disable GVRP globally select 'Disable'.

Port:

The Port column shows the list of ports for which you can configure per port GVRP settings. There are two configuration settings which can be configured on per port bases.

1. GVRP Mode

This configuration is to enable/disable GVRP Mode on particular port locally.

Disable: Select to Disable GVRP mode on this port.

Enable: Select to Enable GVRP mode on this port.

The default value of configuration is disable.

2. GVRP role

This configuration is used to configure restricted role on an interface.

Disable: Select to Disable GVRP role on this port.

Enable: Select to Enable GVRP role on this port.

The default configuration is disable.

Auto-refresh:

Activate the auto-refresh to refresh the information automatically.

Refresh:

Refresh the GVRP Global configuration information manually.

Save – Click to save changes.

Reset – Click to undo any changes made locally and revert to previously saved values.

3.13.2 Statistics

This section describes the basic GVRP Port statistics for all switch ports. The statistics relate to the currently selected unit, as reflected by the page header.

Web Interface

To display GVRP Port statistics in the web interface:

1. Click GVRP statistics.
2. Click Refresh to modify the GVRP statistics information.

Figure 3-13.2: The GVRP Port Statistics

Port	Join Tx Count	Leave Tx Count
1	0	0
2	0	0
3	0	0
4	0	0
5	0	0
6	0	0
7	0	0
8	0	0
9	0	0
10	0	0
11	0	0
12	0	0
13	0	0
14	0	0
15	0	0
16	0	0
17	0	0
18	0	0
19	0	0
20	0	0
21	0	0
22	0	0
23	0	0
24	0	0
25	0	0
26	0	0
27	0	0
28	0	0
29	0	0
30	0	0
31	0	0
32	0	0
33	0	0
34	0	0
35	0	0
36	0	0
37	0	0
38	0	0
39	0	0
40	0	0
41	0	0
42	0	0
43	0	0
44	0	0
45	0	0
46	0	0
47	0	0
48	0	0
49	0	0
50	0	0
51	0	0
52	0	0

Parameter description:

Port:

The Port column shows the list of ports for which you can see port counters and statistics.

Join Tx Count:

The count of GVRP join PDUs transmitted from the GARP layer. (include join in & join empty)

Leave Tx Count:

The count of GVRP leave PDUs transmitted from the GARP layer.(include leave in & leave empty)

Auto-refresh:

Activate the auto-refresh to refresh the information automatically.

Refresh:

Refresh the GVRP Port Statistics information manually.

3.14 QoS

The switch supports four QoS queues per port with strict or weighted fair queuescheduling. It supports QoS Control Lists (QCL) for advance programmable QoS classification, based on IEEE 802.1p, Ethertype, VID, IPv4/IPv6 DSCP and UDP/TCP ports and ranges.

High flexibility in the classification of incoming frames to a QoS class. The QoS classification looks for information up to Layer 4, including IPv4 and IPv6 DSCP, IPv4 TCP/UDP port numbers, and user priority of tagged frames. This QoS classification mechanism is implemented in a QoS control list (QCL). The QoS class assigned to a frame is used throughout the device for providing queuing, scheduling, and congestion control guarantees to the frame according to what was configured for that specific QoS class.

The switch supports advanced memory control mechanisms providing excellent performance of all QoS classes under any traffic scenario, including jumbo frame. A super priority queue with dedicated memory and strict highest priority in the arbitration. The ingress super priority queue allows traffic recognized as CPU traffic to be received and queued for transmission to the CPU even when all the QoS class queues are congested.

3.14.1 Port Classification

The section allows you to configure the basic QoS Ingress Classification settings for all switch ports. and the settings relate to the currently selected unit, as reflected by the page header.

Web Interface

To configure the QoS Port Classification parameters in the web interface:

1. Click Configuration, QoS, Port Classification
2. Select QoS class, DP Level, PCP and DEI parameters
3. Click Save to save the setting
4. If you want to cancel the setting then you need to click the Reset button. It will revert to previously saved values

Figure 3-14.1: The QoS Configuration

Port	QoS class	DP level	PCP	DEI	Tag Class.	DSCP Based
*	<>	<>	<>	<>		<input type="checkbox"/>
1	0	0	0	0	Disabled	<input type="checkbox"/>
2	0	0	0	0	Disabled	<input type="checkbox"/>
3	0	0	0	0	Disabled	<input type="checkbox"/>
4	0	0	0	0	Disabled	<input type="checkbox"/>
5	0	0	0	0	Disabled	<input type="checkbox"/>
6	0	0	0	0	Disabled	<input type="checkbox"/>
7	0	0	0	0	Disabled	<input type="checkbox"/>
8	0	0	0	0	Disabled	<input type="checkbox"/>
9	0	0	0	0	Disabled	<input type="checkbox"/>
10	0	0	0	0	Disabled	<input type="checkbox"/>
11	0	0	0	0	Disabled	<input type="checkbox"/>
12	0	0	0	0	Disabled	<input type="checkbox"/>
13	0	0	0	0	Disabled	<input type="checkbox"/>
14	0	0	0	0	Disabled	<input type="checkbox"/>
15	0	0	0	0	Disabled	<input type="checkbox"/>
16	0	0	0	0	Disabled	<input type="checkbox"/>
17	0	0	0	0	Disabled	<input type="checkbox"/>
18	0	0	0	0	Disabled	<input type="checkbox"/>
19	0	0	0	0	Disabled	<input type="checkbox"/>
20	0	0	0	0	Disabled	<input type="checkbox"/>
21	0	0	0	0	Disabled	<input type="checkbox"/>
22	0	0	0	0	Disabled	<input type="checkbox"/>
23	0	0	0	0	Disabled	<input type="checkbox"/>
24	0	0	0	0	Disabled	<input type="checkbox"/>
25	0	0	0	0	Disabled	<input type="checkbox"/>
26	0	0	0	0	Disabled	<input type="checkbox"/>
27	0	0	0	0	Disabled	<input type="checkbox"/>
28	0	0	0	0	Disabled	<input type="checkbox"/>
29	0	0	0	0	Disabled	<input type="checkbox"/>
30	0	0	0	0	Disabled	<input type="checkbox"/>
31	0	0	0	0	Disabled	<input type="checkbox"/>
32	0	0	0	0	Disabled	<input type="checkbox"/>
33	0	0	0	0	Disabled	<input type="checkbox"/>
34	0	0	0	0	Disabled	<input type="checkbox"/>
35	0	0	0	0	Disabled	<input type="checkbox"/>
36	0	0	0	0	Disabled	<input type="checkbox"/>
37	0	0	0	0	Disabled	<input type="checkbox"/>
38	0	0	0	0	Disabled	<input type="checkbox"/>
39	0	0	0	0	Disabled	<input type="checkbox"/>
40	0	0	0	0	Disabled	<input type="checkbox"/>
41	0	0	0	0	Disabled	<input type="checkbox"/>
42	0	0	0	0	Disabled	<input type="checkbox"/>
43	0	0	0	0	Disabled	<input type="checkbox"/>
44	0	0	0	0	Disabled	<input type="checkbox"/>
45	0	0	0	0	Disabled	<input type="checkbox"/>
46	0	0	0	0	Disabled	<input type="checkbox"/>
47	0	0	0	0	Disabled	<input type="checkbox"/>
48	0	0	0	0	Disabled	<input type="checkbox"/>
49	0	0	0	0	Disabled	<input type="checkbox"/>
50	0	0	0	0	Disabled	<input type="checkbox"/>
51	0	0	0	0	Disabled	<input type="checkbox"/>
52	0	0	0	0	Disabled	<input type="checkbox"/>

Save Reset

Parameter description:

Port:

The port number for which the configuration below applies.

QoS class:

Controls the default QoS class, i.e., the QoS class for frames not classified in any other way. There is a one to one mapping between QoS class, queue and priority. A QoS class of 0 (zero) has the lowest priority.

DP level:

Controls the default DP level, i.e., the DP level for frames not classified in any other way.

PCP:

Controls the default PCP for untagged frames.

DEI:

Controls the default DEI for untagged frames.

Tag Class.:

Shows the classification mode for tagged frames on this port.

Disabled: Use default QoS class and DP level for tagged frames.

Enabled: Use mapped versions of PCP and DEI for tagged frames.

Click on the mode in order to configure the mode and/or mapping.

DSCP Based:

Click to Enable DSCP Based QoS Ingress Port Classification.

Buttons:

Save – Click to save changes.

Reset – Click to undo any changes made locally and revert to previously saved values.



DP level: Every incoming frame is classified to a Drop Precedence Level (DP level), which is used throughout the device for providing congestion control guarantees to the frame according to what was configured for that specific DP level.

PCP: PCP is an acronym for Priority Code Point. It is a 3-bit field storing the priority level for the 802.1Q frame.

DEI: DEI is an acronym for Drop Eligible Indicator. It is a 1-bit field in the VLAN tag.

Actual PCP is Pri column in VLAN tag packet, DEI is cfi column

PCP value from 0~7, it can be used for priority definition.

DEI value is 0 or 1, it is settable; map to DP value is 0 or 1. When ingress QoS class value is the same, the DP level defines the priority, a large DP value will be dropped first.

ex: From Port 1 input 1G Pkts, Egress Port 7 Rate be set with 500M. Port 1 Pkts will include two kinds of packets:

- a. PCP & DEI = 0 0, via configured map to QoS class & DP level = 1, 0
- b. PCP & DEI = 0 1, via configured map to QoS class & DP level = 1, 1

Result will find: (a) all packets past, and (b) all packets dropped

3.14.2 Port Policing

This section provides an overview of QoS Ingress Port Polices for all switch ports The Port Policing is useful in constraining traffic flows and marking frames above specific rates. Policing is primarily useful for data flows and voice or video flows because voice and video usually maintains a steady rate of traffic

Web Interface

To display the QoS Port Schedulers in the web interface:

1. Click Configuration, QoS, Port Policing
2. Activate which port need to enable the QoS Ingress Port Polices and type the Rate limit condition.
3. Select the Rate limit Unit with kbps, Mbps, fps, or kfps.
4. Click Save to save the configuration.

Figure 3-14.2: The QoS Ingress Port Policies Configuration

QoS Ingress Port Policers

Port	Mode	Rate	Unit	Flow Control
*	<input type="checkbox"/>	500	<>	<input type="checkbox"/>
1	<input type="checkbox"/>	500	kpbs	<input type="checkbox"/>
2	<input type="checkbox"/>	500	kpbs	<input type="checkbox"/>
3	<input type="checkbox"/>	500	kpbs	<input type="checkbox"/>
4	<input type="checkbox"/>	500	kpbs	<input type="checkbox"/>
5	<input type="checkbox"/>	500	kpbs	<input type="checkbox"/>
6	<input type="checkbox"/>	500	kpbs	<input type="checkbox"/>
7	<input type="checkbox"/>	500	kpbs	<input type="checkbox"/>
8	<input type="checkbox"/>	500	kpbs	<input type="checkbox"/>
9	<input type="checkbox"/>	500	kpbs	<input type="checkbox"/>
10	<input type="checkbox"/>	500	kpbs	<input type="checkbox"/>
11	<input type="checkbox"/>	500	kpbs	<input type="checkbox"/>
12	<input type="checkbox"/>	500	kpbs	<input type="checkbox"/>
13	<input type="checkbox"/>	500	kpbs	<input type="checkbox"/>
14	<input type="checkbox"/>	500	kpbs	<input type="checkbox"/>
15	<input type="checkbox"/>	500	kpbs	<input type="checkbox"/>
16	<input type="checkbox"/>	500	kpbs	<input type="checkbox"/>
17	<input type="checkbox"/>	500	kpbs	<input type="checkbox"/>
18	<input type="checkbox"/>	500	kpbs	<input type="checkbox"/>
19	<input type="checkbox"/>	500	kpbs	<input type="checkbox"/>
20	<input type="checkbox"/>	500	kpbs	<input type="checkbox"/>
21	<input type="checkbox"/>	500	kpbs	<input type="checkbox"/>
22	<input type="checkbox"/>	500	kpbs	<input type="checkbox"/>
23	<input type="checkbox"/>	500	kpbs	<input type="checkbox"/>
24	<input type="checkbox"/>	500	kpbs	<input type="checkbox"/>
25	<input type="checkbox"/>	500	kpbs	<input type="checkbox"/>
26	<input type="checkbox"/>	500	kpbs	<input type="checkbox"/>
27	<input type="checkbox"/>	500	kpbs	<input type="checkbox"/>
28	<input type="checkbox"/>	500	kpbs	<input type="checkbox"/>
29	<input type="checkbox"/>	500	kpbs	<input type="checkbox"/>
30	<input type="checkbox"/>	500	kpbs	<input type="checkbox"/>
31	<input type="checkbox"/>	500	kpbs	<input type="checkbox"/>
32	<input type="checkbox"/>	500	kpbs	<input type="checkbox"/>
33	<input type="checkbox"/>	500	kpbs	<input type="checkbox"/>
34	<input type="checkbox"/>	500	kpbs	<input type="checkbox"/>
35	<input type="checkbox"/>	500	kpbs	<input type="checkbox"/>
36	<input type="checkbox"/>	500	kpbs	<input type="checkbox"/>
37	<input type="checkbox"/>	500	kpbs	<input type="checkbox"/>
38	<input type="checkbox"/>	500	kpbs	<input type="checkbox"/>
39	<input type="checkbox"/>	500	kpbs	<input type="checkbox"/>
40	<input type="checkbox"/>	500	kpbs	<input type="checkbox"/>
41	<input type="checkbox"/>	500	kpbs	<input type="checkbox"/>
42	<input type="checkbox"/>	500	kpbs	<input type="checkbox"/>
43	<input type="checkbox"/>	500	kpbs	<input type="checkbox"/>
44	<input type="checkbox"/>	500	kpbs	<input type="checkbox"/>
45	<input type="checkbox"/>	500	kpbs	<input type="checkbox"/>
46	<input type="checkbox"/>	500	kpbs	<input type="checkbox"/>
47	<input type="checkbox"/>	500	kpbs	<input type="checkbox"/>
48	<input type="checkbox"/>	500	kpbs	<input type="checkbox"/>
49	<input type="checkbox"/>	500	kpbs	<input type="checkbox"/>
50	<input type="checkbox"/>	500	kpbs	<input type="checkbox"/>
51	<input type="checkbox"/>	500	kpbs	<input type="checkbox"/>
52	<input type="checkbox"/>	500	kpbs	<input type="checkbox"/>

Save Reset

Parameter description:

Port:

The logical port for the settings contained in the same row. Click on the port number in order to configure the schedulers.

Enabled:

To activate which Port you need to enable the QoS Ingress Port Policies function.

Rate:

To set the Rate limit value for this port, the default is 500.

Unit:

To scroll to select what unit of rate includes kpbs, Mbps, fps and kfps. The default is kpbs.

Flow Control:

Activate to enable or disable flow control on port.

Buttons:

Save – Click to save changes.

Reset – Click to undo any changes made locally and revert to previously saved values.

3.14.3 Port Scheduler

This section provides an overview of QoS Egress Port Schedulers for all switch ports. The ports belong to the currently selected unit, as reflected by the page header.

Web Interface

To display the QoS Port Schedulers in the web interface:

1. Click Configuration, QoS, Port Schedulers

2. Display the QoS Egress Port Schedulers

Figure 3-14.3: The QoS Egress Port Schedules

QoS Egress Port Schedulers							
Port	Mode	Weight					
		Q0	Q1	Q2	Q3	Q4	Q5
1	Strict Priority	-	-	-	-	-	-
2	Strict Priority	-	-	-	-	-	-
3	Strict Priority	-	-	-	-	-	-
4	Strict Priority	-	-	-	-	-	-
5	Strict Priority	-	-	-	-	-	-
6	Strict Priority	-	-	-	-	-	-
7	Strict Priority	-	-	-	-	-	-
8	Strict Priority	-	-	-	-	-	-
9	Strict Priority	-	-	-	-	-	-
40	Strict Priority	-	-	-	-	-	-
41	Strict Priority	-	-	-	-	-	-
42	Strict Priority	-	-	-	-	-	-
43	Strict Priority	-	-	-	-	-	-
44	Strict Priority	-	-	-	-	-	-
45	Strict Priority	-	-	-	-	-	-
46	Strict Priority	-	-	-	-	-	-
47	Strict Priority	-	-	-	-	-	-
48	Strict Priority	-	-	-	-	-	-
49	Strict Priority	-	-	-	-	-	-
50	Strict Priority	-	-	-	-	-	-
51	Strict Priority	-	-	-	-	-	-
52	Strict Priority	-	-	-	-	-	-

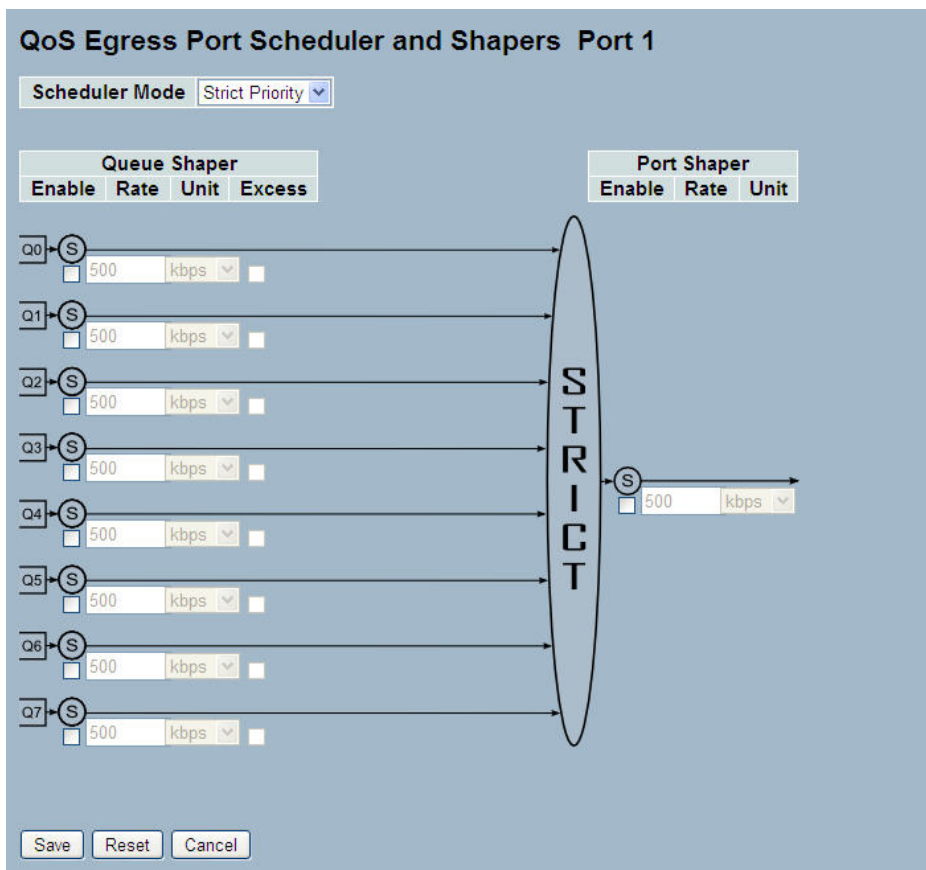

QoS Egress Port Scheduler and Shapers Port 1

Scheduler Mode: Weighted

Queue Shaper				Queue Scheduler		Port Shaper		
Enable	Rate	Unit	Excess	Weight	Percent	Enable	Rate	Unit
<input type="checkbox"/>	500	kbps	<input type="checkbox"/>	17	17%			
<input type="checkbox"/>	500	kbps	<input type="checkbox"/>	17	17%			
<input type="checkbox"/>	500	kbps	<input type="checkbox"/>	17	17%			
<input type="checkbox"/>	500	kbps	<input type="checkbox"/>	17	17%			
<input type="checkbox"/>	500	kbps	<input type="checkbox"/>	17	17%			
<input type="checkbox"/>	500	kbps	<input type="checkbox"/>	17	17%			
<input type="checkbox"/>	500	kbps	<input type="checkbox"/>					
<input type="checkbox"/>	500	kbps	<input type="checkbox"/>				500	kbps

Diagram illustrating the QoS Egress Port Scheduler and Shapers configuration for Port 1. The configuration shows 8 queues (Q0-Q7) feeding into a DRR (Distributed Round Robin) scheduler, which then feeds into a STRICT scheduler. The output of the STRICT scheduler is then shaped by a Port Shaper. The Port Shaper is configured with a rate of 500 kbps. The Queue Scheduler is configured with a weight of 17 and a percent of 17% for each queue. The Queue Shaper is configured with a rate of 500 kbps and a unit of kbps for each queue. The Port Shaper is configured with a rate of 500 kbps and a unit of kbps. The Scheduler Mode is set to Weighted.

Buttons: Save, Reset, Cancel

Parameter description:

Port:

The logical port for the settings contained in the same row. Click on the port number in order to configure the schedulers.

Mode:

Shows the scheduling mode for this port.

Weight (Qn):

Shows the weight for this queue and port.

Scheduler Mode:

Controls whether the scheduler mode is "Strict Priority" or "Weighted" on this switch port.

Queue Shaper Enable:

Controls whether the queue shaper is enabled for this queue on this switch port.

Queue Shaper Rate:

Controls the rate for the queue shaper. The default value is ?. This value is restricted to ?-1000000 when the "Unit" is "kbps", and it is restricted to 1-? when the "Unit" is "Mbps".

Queue Shaper Unit:

Controls the unit of measure for the queue shaper rate as "kbps" or "Mbps". The default value is "kbps".

Queue Shaper Excess:

Controls whether the queue is allowed to use excess bandwidth.

Queue Scheduler Weight:

Controls the weight for this queue. The default value is "17". This value is restricted to 1-100. This parameter is only shown if "Scheduler Mode" is set to "Weighted".

Queue Scheduler Percent:

Shows the weight in percent for this queue. This parameter is only shown if "Scheduler Mode" is set to "Weighted"

Port Shaper Enable:

Controls whether the port shaper is enabled for this switch port.

Port Shaper Rate:

Controls the rate for the port shaper. The default value is ?. This value is restricted to ?-1000000 when the "Unit" is "kbps", and it is restricted to 1-? when the "Unit" is "Mbps".

Port Shaper Unit:

Controls the unit of measure for the port shaper rate as "kbps" or "Mbps". The default value is "kbps".

Buttons:

Save – Click to save changes.

Reset – Click to undo any changes made locally and revert to previously saved values.

3.14.4 Port Shaping

This section provides an overview of QoS Egress Port Shaping for all switch ports. It offers all detail information of the ports belonging to the currently selected unit, as reflected by the page header.

Web Interface

To display the QoS Port Shapers in the web interface:

1. Click Configuration, QoS, Port Shapers

Figure 3-14.4: The QoS Egress Port Shapers

QoS Egress Port Shapers									
Port	Shapers								
	Q0	Q1	Q2	Q3	Q4	Q5	Q6	Q7	Port
1	disabled	disabled	disabled	disabled	disabled	disabled	disabled	disabled	disabled
2	disabled	disabled	disabled	disabled	disabled	disabled	disabled	disabled	disabled
3	disabled	disabled	disabled	disabled	disabled	disabled	disabled	disabled	disabled
4	disabled	disabled	disabled	disabled	disabled	disabled	disabled	disabled	disabled
5	disabled	disabled	disabled	disabled	disabled	disabled	disabled	disabled	disabled
6	disabled	disabled	disabled	disabled	disabled	disabled	disabled	disabled	disabled
7	disabled	disabled	disabled	disabled	disabled	disabled	disabled	disabled	disabled
8	disabled	disabled	disabled	disabled	disabled	disabled	disabled	disabled	disabled
9	disabled	disabled	disabled	disabled	disabled	disabled	disabled	disabled	disabled
10	disabled	disabled	disabled	disabled	disabled	disabled	disabled	disabled	disabled
11	disabled	disabled	disabled	disabled	disabled	disabled	disabled	disabled	disabled
12	disabled	disabled	disabled	disabled	disabled	disabled	disabled	disabled	disabled
13	disabled	disabled	disabled	disabled	disabled	disabled	disabled	disabled	disabled
14	disabled	disabled	disabled	disabled	disabled	disabled	disabled	disabled	disabled
15	disabled	disabled	disabled	disabled	disabled	disabled	disabled	disabled	disabled
16	disabled	disabled	disabled	disabled	disabled	disabled	disabled	disabled	disabled
17	disabled	disabled	disabled	disabled	disabled	disabled	disabled	disabled	disabled
18	disabled	disabled	disabled	disabled	disabled	disabled	disabled	disabled	disabled
19	disabled	disabled	disabled	disabled	disabled	disabled	disabled	disabled	disabled
20	disabled	disabled	disabled	disabled	disabled	disabled	disabled	disabled	disabled
21	disabled	disabled	disabled	disabled	disabled	disabled	disabled	disabled	disabled
22	disabled	disabled	disabled	disabled	disabled	disabled	disabled	disabled	disabled
23	disabled	disabled	disabled	disabled	disabled	disabled	disabled	disabled	disabled
24	disabled	disabled	disabled	disabled	disabled	disabled	disabled	disabled	disabled
25	disabled	disabled	disabled	disabled	disabled	disabled	disabled	disabled	disabled
26	disabled	disabled	disabled	disabled	disabled	disabled	disabled	disabled	disabled

QoS Egress Port Scheduler and Shapers Port 1

Scheduler Mode: **Strict Priority**

Queue Shaper				Port Shaper		
Enable	Rate	Unit	Excess	Enable	Rate	Unit
<input type="checkbox"/>	500	kbps	<input type="checkbox"/>	<input type="checkbox"/>	500	kbps
<input type="checkbox"/>	500	kbps	<input type="checkbox"/>	<input type="checkbox"/>	500	kbps
<input type="checkbox"/>	500	kbps	<input type="checkbox"/>	<input type="checkbox"/>	500	kbps
<input type="checkbox"/>	500	kbps	<input type="checkbox"/>	<input type="checkbox"/>	500	kbps
<input type="checkbox"/>	500	kbps	<input type="checkbox"/>	<input type="checkbox"/>	500	kbps
<input type="checkbox"/>	500	kbps	<input type="checkbox"/>	<input type="checkbox"/>	500	kbps
<input type="checkbox"/>	500	kbps	<input type="checkbox"/>	<input type="checkbox"/>	500	kbps
<input type="checkbox"/>	500	kbps	<input type="checkbox"/>	<input type="checkbox"/>	500	kbps

Diagram: A central vertical oval labeled "STRICT" receives input from eight queues (Q0-Q7). Each queue has a shaper icon (S) and a rate of 500 kbps. A single output line from the "STRICT" oval has a shaper icon (S) and a rate of 500 kbps.

Buttons: Save, Reset, Cancel

QoS Egress Port Scheduler and Shapers Port 1

Scheduler Mode: **Weighted**

Queue Shaper				Queue Scheduler		Port Shaper		
Enable	Rate	Unit	Excess	Weight	Percent	Enable	Rate	Unit
<input type="checkbox"/>	500	kbps	<input type="checkbox"/>	17	17%	<input type="checkbox"/>	500	kbps
<input type="checkbox"/>	500	kbps	<input type="checkbox"/>	17	17%	<input type="checkbox"/>	500	kbps
<input type="checkbox"/>	500	kbps	<input type="checkbox"/>	17	17%	<input type="checkbox"/>	500	kbps
<input type="checkbox"/>	500	kbps	<input type="checkbox"/>	17	17%	<input type="checkbox"/>	500	kbps
<input type="checkbox"/>	500	kbps	<input type="checkbox"/>	17	17%	<input type="checkbox"/>	500	kbps
<input type="checkbox"/>	500	kbps	<input type="checkbox"/>	17	17%	<input type="checkbox"/>	500	kbps
<input type="checkbox"/>	500	kbps	<input type="checkbox"/>	17	17%	<input type="checkbox"/>	500	kbps
<input type="checkbox"/>	500	kbps	<input type="checkbox"/>	17	17%	<input type="checkbox"/>	500	kbps

Diagram: A central vertical oval labeled "DWR" (Distributed Weighted Round Robin) receives input from eight queues (Q0-Q7). Each queue has a shaper icon (S) and a rate of 500 kbps. A second vertical oval labeled "STRICT" receives input from the "DWR" oval. A single output line from the "STRICT" oval has a shaper icon (S) and a rate of 500 kbps.

Buttons: Save, Reset, Cancel

Parameter description:

Port:

The logical port for the settings contained in the same row. Click on the port number in order to configure the shapers.

Shapers (Qn):

Shows "disabled" or actual queue shaper rate - e.g. "800 Mbps".

Shapers (Port):

Shows "disabled" or actual port shaper rate - e.g. "800 Mbps".

Scheduler Mode:

Controls whether the scheduler mode is "Strict Priority" or "Weighted" on this switch port.

Queue Shaper Enable:

Controls whether the queue shaper is enabled for this queue on this switch port.

Queue Shaper Rate:

Controls the rate for the queue shaper. The default value is ?. This value is restricted to ?-1000000 when the "Unit" is "kbps", and it is restricted to 1-? when the "Unit" is "Mbps".

Queue Shaper Unit:

Controls the unit of measure for the queue shaper rate as "kbps" or "Mbps". The default value is "kbps".

Queue Shaper Excess:

Controls whether the queue is allowed to use excess bandwidth.

Queue Scheduler Weight:

Controls the weight for this queue. The default value is "17". This value is restricted to 1-100. This parameter is only shown if "Scheduler Mode" is set to "Weighted".

Queue Scheduler Percent:

Shows the weight in percent for this queue. This parameter is only shown if "Scheduler Mode" is set to "Weighted"

Port Shaper Enable:

Controls whether the port shaper is enabled for this switch port.

Port Shaper Rate:

Controls the rate for the port shaper. The default value is ?. This value is restricted to ?-1000000 when the "Unit" is "kbps", and it is restricted to 1-? when the "Unit" is "Mbps".

Port Shaper Unit:

Controls the unit of measure for the port shaper rate as "kbps" or "Mbps". The default value is "kbps".

Buttons:

Save – Click to save changes.

Reset – Click to undo any changes made locally and revert to previously saved values.

3.14.5 Port Tag Remarking

This Section provides an overview of QoS Egress Port Tag Remarking for all switch ports.

Web Interface

To display the QoS Port Tag Remarking in the web interface:

Click Configuration, QoS, Port Tag Remarking

Figure 3-14.5: The Port Tag Remarking

QoS Egress Port Tag Remarking

Port	Mode
1	Classified
2	Classified
3	Classified
4	Classified
5	Classified
6	Classified
7	Classified
8	Classified
9	Classified
10	Classified
11	Classified
12	Classified
13	Classified
14	Classified
15	Classified
16	Classified
17	Classified
18	Classified
19	Classified
20	Classified
21	Classified
22	Classified
23	Classified
24	Classified
25	Classified
26	Classified

QoS Egress Port Tag Remarking Port 1

Tag Remarking Mode:

Parameter description:

Port:

The logical port for the settings contained in the same row. Click on the port number in order to configure tag remarking.

Mode:

Shows the tag remarking mode for this port.

Classified: Use classified PCP/DEI values.

Default: Use default PCP/DEI values.

Mapped: Use mapped versions of QoS class and DP level.

Tag Remarking Mode:

To scroll to select the tag remarking mode for this port.

Classified: Use classified PCP/DEI values.

Default: Use default PCP/DEI values.

Mapped: Use mapped versions of QoS class and DP level.

Buttons:

Save – Click to save changes.

Reset – Click to undo any changes made locally and revert to previously saved values.

Cancel – Click to cancel the changes.

3.14.6 Port DSCP

This section shows how to configure the QoS Port DSCP settings for all switch ports.

Web Interface

To configure the QoS Port DSCP parameters in the web interface:

1. Click Configuration, QoS, Port DSCP
2. Activate to enable or disable the Ingress Translate and Scroll the Classify Parameter configuration
3. Select Egress Rewrite parameters
4. Click Save to save the setting
5. If you want to cancel the setting then you need to click the Reset button.

It will revert to previously saved values

Figure 3-14.6: The QoS Port DSCP Configuration

Port	Ingress		Egress
	Translate	Classify	Rewrite
*	<input type="checkbox"/>	<>	<>
1	<input type="checkbox"/>	Disable	Disable
2	<input type="checkbox"/>	Disable	Disable
3	<input type="checkbox"/>	Disable	Disable
4	<input type="checkbox"/>	Disable	Disable
5	<input type="checkbox"/>	Disable	Disable
6	<input type="checkbox"/>	Disable	Disable
7	<input type="checkbox"/>	Disable	Disable
8	<input type="checkbox"/>	Disable	Disable
9	<input type="checkbox"/>	Disable	Disable
10	<input type="checkbox"/>	Disable	Disable
43	<input type="checkbox"/>	Disable	Disable
44	<input type="checkbox"/>	Disable	Disable
45	<input type="checkbox"/>	Disable	Disable
46	<input type="checkbox"/>	Disable	Disable
47	<input type="checkbox"/>	Disable	Disable
48	<input type="checkbox"/>	Disable	Disable
49	<input type="checkbox"/>	Disable	Disable
50	<input type="checkbox"/>	Disable	Disable
51	<input type="checkbox"/>	Disable	Disable
52	<input type="checkbox"/>	Disable	Disable

Save Reset

Parameter description:

Port:

The Port column shows the list of ports for which you can configure dscp ingress and egress settings.

Ingress:

In Ingress settings you can change ingress translation and classification settings for individual ports.

There are two configuration parameters available in Ingress:

Translate: To Enable the Ingress Translation click the checkbox

Classify: Classification for a port have 4 different values

Disable: No Ingress DSCP Classification.

DSCP=0: Classify if incoming (or translated if enabled) DSCP is 0.

Selected: Classify only selected DSCP for which classification is enabled as specified in DSCP Translation window for the specific DSCP.

All: Classify all DSCP.

Egress:

Port Egress Rewriting can be one of below parameters

Disable: No Egress rewrite.

Enable: Rewrite enable without remapped.

Remap: DSCP from analyzer is remapped and frame is remarked with remapped DSCP value.

Buttons:

Save – Click to save changes.

Reset – Click to undo any changes made locally and revert to previously saved values.

3.14.7 DSCP-Based QoS

This section shows how to configure the DSCP-Based QoS mode.

Web Interface

To configure the DSCP –Based QoS Ingress Classification parameters in the web interface:

1. Click Configuration, QoS, DSCP-Based QoS
2. Activate to enable or disable the DSCP for Trust
3. Select QoS Class and DPL parameters
4. Click Save to save the setting
5. If you want to cancel the setting then you need to click the Reset button. It will revert to previously saved values

Figure 3-14.7: The DSCP-Based QoS Ingress Classification Configuration

DSCP-Based QoS Ingress Classification

DSCP	Trust	QoS Class	DPL
*	<input type="checkbox"/>	<> ▾	<> ▾
0 (BE)	<input type="checkbox"/>	0 ▾	0 ▾
1	<input type="checkbox"/>	0 ▾	0 ▾
2	<input type="checkbox"/>	0 ▾	0 ▾
3	<input type="checkbox"/>	0 ▾	0 ▾
4	<input type="checkbox"/>	0 ▾	0 ▾
5	<input type="checkbox"/>	0 ▾	0 ▾
6	<input type="checkbox"/>	0 ▾	0 ▾
7	<input type="checkbox"/>	0 ▾	0 ▾
8 (CS1)	<input type="checkbox"/>	0 ▾	0 ▾
9	<input type="checkbox"/>	0 ▾	0 ▾
10 (AF11)	<input type="checkbox"/>	0 ▾	0 ▾
11	<input type="checkbox"/>	0 ▾	0 ▾
12 (AF12)	<input type="checkbox"/>	0 ▾	0 ▾
13	<input type="checkbox"/>	0 ▾	0 ▾
14 (AF13)	<input type="checkbox"/>	0 ▾	0 ▾
15	<input type="checkbox"/>	0 ▾	0 ▾
16 (CS2)	<input type="checkbox"/>	0 ▾	0 ▾
17	<input type="checkbox"/>	0 ▾	0 ▾
18 (AF21)	<input type="checkbox"/>	0 ▾	0 ▾
59	<input checked="" type="checkbox"/>	0 ▾	0 ▾
60	<input checked="" type="checkbox"/>	0 ▾	0 ▾
61	<input checked="" type="checkbox"/>	0 ▾	0 ▾
62	<input checked="" type="checkbox"/>	0 ▾	0 ▾
63	<input checked="" type="checkbox"/>	0 ▾	0 ▾

Parameter description:

DSCP:

Maximum number of supported DSCP values are 64.

Trust:

Click to check if the DSCP value is trusted.

QoS Class:

QoS Class value can be any of (0-7)

DPL:

Drop Precedence Level (0-3)

Buttons:

Save – Click to save changes.

Reset – Click to undo any changes made locally and revert to previously saved values.

3.14.8 DSCP Translation

The section describes how to configure the basic QoS DSCP Translation settings for all switches. DSCP translation can be done in Ingress or Egress.

Web Interface

To configure the DSCP Translation parameters in the web interface:

1. Click Configuration, QoS, DSCP Translation
2. Set the Ingress Translate and Egress Remap DP0 and Remap

DP1 Parameters

3. Activate to enable or disable Classify
4. Click Save to save the setting
5. If you want to cancel the setting then you need to click the Reset button. It will revert to previously saved values

Figure 3-14.8: The DSCP Translation Configuration

DSCP	Ingress		Egress	
	Translate	Classify	Remap DP0	Remap DP1
*	<>	<input type="checkbox"/>	<>	<>
0 (BE)	0 (BE)	<input type="checkbox"/>	0 (BE)	0 (BE)
1	1	<input type="checkbox"/>	1	1
2	2	<input type="checkbox"/>	2	2
3	3	<input type="checkbox"/>	3	3
4	4	<input type="checkbox"/>	4	4
5	5	<input type="checkbox"/>	5	5
6	6	<input type="checkbox"/>	6	6
7	7	<input type="checkbox"/>	7	7
8 (CS1)	8 (CS1)	<input type="checkbox"/>	8 (CS1)	8 (CS1)
9	9	<input type="checkbox"/>	9	9
10 (AF11)	10 (AF11)	<input type="checkbox"/>	10 (AF11)	10 (AF11)
11	11	<input type="checkbox"/>	11	11
12 (AF12)	12 (AF12)	<input type="checkbox"/>	12 (AF12)	12 (AF12)
13	13	<input type="checkbox"/>	13	13
14 (AF13)	14 (AF13)	<input type="checkbox"/>	14 (AF13)	14 (AF13)
15	15	<input type="checkbox"/>	15	15
16 (CS2)	16 (CS2)	<input type="checkbox"/>	16 (CS2)	16 (CS2)
17	17	<input type="checkbox"/>	17	17

49	49	<input type="checkbox"/>	49	49
50	50	<input type="checkbox"/>	50	50
51	51	<input type="checkbox"/>	51	51
52	52	<input type="checkbox"/>	52	52
53	53	<input type="checkbox"/>	53	53
54	54	<input type="checkbox"/>	54	54
55	55	<input type="checkbox"/>	55	55
56 (CS7)	56 (CS7)	<input type="checkbox"/>	56 (CS7)	56 (CS7)
57	57	<input type="checkbox"/>	57	57
58	58	<input type="checkbox"/>	58	58
59	59	<input type="checkbox"/>	59	59
60	60	<input type="checkbox"/>	60	60
61	61	<input type="checkbox"/>	61	61
62	62	<input type="checkbox"/>	62	62
63	63	<input type="checkbox"/>	63	63

Save Reset

Parameter description:

DSCP:

Maximum number of supported DSCP values are 64 and valid DSCP value ranges from 0 to 63.

Ingress:

Ingress side DSCP can be first translated to new DSCP before using the DSCP for QoS class and DPL map.

There are two configuration parameters for DSCP Translation –

Translate: DSCP at Ingress side can be translated to any of (0-63) DSCP values.

Classify: Click to enable Classification at Ingress side.

Egress:

There are following configurable parameters for Egress side –

Remap DP0: Select the DSCP value from select menu to which you want to remap. DSCP value ranges form 0 to 63

Remap DP1: Select the DSCP value from select menu to which you want to remap. DSCP value ranges form 0 to 63.

There is following configurable parameter for Egress side -

Remap: Select the DSCP value from select menu to which you want to remap. DSCP value ranges form 0 to 63.

Buttons:

Save – Click to save changes.

Reset – Click to undo any changes made locally and revert to previously saved values.

3.14.9 DSCP Classification

The section describes how to configure and map DSCP value to a QoS Class and DPL value.

Web Interface

To configure the DSCP Classification parameters in the web interface:

1. Click Configuration, QoS, DSCP Translation
2. Set the DSCP Parameters
3. Click Save to save the setting
4. If you want to cancel the setting then you need to click the Reset button. It will revert to previously saved values

Figure 3-14.9: The DSCP Classification Configuration

QoS Class	DPL	DSCP
*	*	<>
0	0	0 (BE)
0	1	0 (BE)
1	0	0 (BE)
1	1	0 (BE)
2	0	0 (BE)
2	1	0 (BE)
3	0	0 (BE)
3	1	0 (BE)
4	0	0 (BE)
4	1	0 (BE)
5	0	0 (BE)
5	1	0 (BE)
6	0	0 (BE)
6	1	0 (BE)
7	0	0 (BE)
7	1	0 (BE)

Save Reset

Parameter description:

QoS Class:

Available QoS Class value ranges from 0 to 7. QoS Class (0-7) can be mapped to followed parameters.

DPL:

Drop Precedence Level (0-1) can be configured for all available QoS Classes.

DSCP:

Select DSCP value (0-63) from DSCP menu to map DSCP to corresponding QoS Class and DPL value

Buttons:

Save – Click to save changes.

Reset – Click to undo any changes made locally and revert to previously saved values.

3.14.10 QoS Control List Configuration

The section shows the QoS Control List(QCL), which is made up of the QCEs. Each row describes a QCE that is defined. The maximum number of QCEs is 256 on each switch. Click on the lowest plus sign to add a new QCE to the list.

Web Interface

To configure the QoS Control List parameters in the web interface:

1. Click Configuration, QoS, QoS Control List
2. Click the  to add a new QoS Control List
3. Select the parameters and activate the Port Member to join the QCE rules
4. Click Save to save the setting
5. If you want to cancel the setting then you need to click the Reset button. It will revert to previously saved values

Figure 3-14.10: The QoS Control List Configuration

QoS Control List Configuration

QCE#	Port	Frame Type	SMAC	DMAC	VID	Action		
						Class	DPL	DSCP

QCE Configuration

																			Port Members	
1	2	3	4	5	6	7	8	9	10	11	12	13	14	15	16	17	18	19		
<input checked="" type="checkbox"/>	<input checked="" type="checkbox"/>	<input checked="" type="checkbox"/>	<input checked="" type="checkbox"/>	<input checked="" type="checkbox"/>	<input checked="" type="checkbox"/>	<input checked="" type="checkbox"/>	<input checked="" type="checkbox"/>	<input checked="" type="checkbox"/>	<input checked="" type="checkbox"/>	<input checked="" type="checkbox"/>	<input checked="" type="checkbox"/>	<input checked="" type="checkbox"/>	<input checked="" type="checkbox"/>	<input checked="" type="checkbox"/>	<input checked="" type="checkbox"/>	<input checked="" type="checkbox"/>	<input checked="" type="checkbox"/>	<input checked="" type="checkbox"/>		

Key Parameters

Tag	Any	▼
VID	Any	▼
PCP	Any	▼
DEI	Any	▼
SMAC	Any	▼
DMAC Type	Any	▼
Frame Type	Any	▼

Action Parameters

Class	0	▼
DPL	Default	▼
DSCP	Default	▼

Apply Reset Cancel

Parameter description:

QCE#:

Indicates the index of QCE.

Port:

Indicates the list of ports configured with the QCE.

Frame Type:

Indicates the type of frame to look for incoming frames. Possible frame types are:

Any: The QCE will match all frame type.

Ethernet: Only Ethernet frames (with Ether Type 0x600-0xFFFF) are allowed.

LLC: Only (LLC) frames are allowed.

SNAP: Only (SNAP) frames are allowed

IPv4: The QCE will match only IPV4 frames.

IPv6: The QCE will match only IPV6 frames.

SMAC:

Displays the OUI field of Source MAC address, i.e. first three octet (byte) of MAC address.

DMAC:

Specify the type of Destination MAC addresses for incoming frame. Possible values are:

Any: All types of Destination MAC addresses are allowed.

Unicast: Only Unicast MAC addresses are allowed.

Multicast: Only Multicast MAC addresses are allowed.

Broadcast: Only Broadcast MAC addresses are allowed.

The default value is 'Any'.

3 Configuration

VID:

Indicates (VLAN ID), either a specific VID or range of VIDs. VID can be in the range 1-4095 or 'Any'

Conflict:

Displays QCE status. It may happen that resources required to add a QCE may not available, in that case it shows conflict status as 'Yes', otherwise it is always 'No'. Please note that conflict can be resolved by releasing the resource required by the QCE and pressing 'Refresh' button.

Action:

Indicates the classification action taken on ingress frame if parameters configured are matched with the frame's content.

There are three action fields: Class, DPL and DSCP.







Class: Classified QoS Class; if a frame matches the QCE it will be put in the queue.

DPL: Drop Precedence Level; if a frame matches the QCE then DP level will set to value displayed under DPL column.

DSCP: If a frame matches the QCE then DSCP will be classified with the value displayed under DSCP column.

Modification Buttons:

You can modify each QCE (QoS Control Entry) in the table using the following buttons:

-  Inserts a new QCE before the current row.
-  Edits the QCE.
-  Moves the QCE up the list.
-  Moves the QCE down the list.
-  Deletes the QCE.
-  The lowest plus sign adds a new entry at the bottom of the QCE listings.

Port Members:

Check the checkbox button to include the port as member in the QCL entry. By default all ports will be checked

Key Parameters:

Key configuration are described as below:

Tag Value of Tag field can be 'Any', 'Untag' or 'Tag'

VID Valid value of VLAN ID can be any value in the range 1-4095 or 'Any'; user can enter either a specific value or a range of VIDs

PCP Priority Code Point: Valid value PCP are specific(0, 1, 2, 3, 4, 5, 6, 7) or range(0-1, 2-3, 4-5, 6-7, 0-3, 4-7) or 'Any'

DEI Drop Eligible Indicator: Valid value of DEI can be any of values between 0, 1 or 'Any'

SMAC Source MAC address: 24 MS bits (OUI) or 'Any'

DMAC Type Destination MAC type: possible values are unicast(UC), multicast(MC), broadcast(BC) or 'Any'

Frame Type Frame Type can have any of the following values

Any

Ethernet

LLC

SNAP

IPv4

IPv6



All frame types are explained below:

1. Any: Allow all types of frames.
2. Ethernet: Ethernet Type Valid Ethernet type can have values within 0x600-0xFFFF or 'Any', default value is 'Any'.
3. LLC: SSAP Address Valid SSAP (Source Service Access Point) can vary from 0x00 to 0xFF or 'Any', the default value is 'Any' DSAP Address Valid DSAP(Destination Service Access Point) can vary from 0x00 to 0xFF or 'Any', the default value is 'Any' Control Address Valid Control Address can vary from 0x00 to 0xFF or 'Any', the default value is 'Any'
4. SNAP: PID Valid PID (a.k.a Ethernet type) can have a value within 0x00-0xFFFF or 'Any', default value is 'Any'
5. IPv4: Protocol IP protocol number: (0-255, TCP or UDP) or 'Any' Source IP Specific Source IP address in value/mask format or 'Any'. IP and Mask are in the format x.y.z.w where x, y, z, and w are decimal numbers between 0 and 255. When Mask is converted to a 32-bit binary string and read from left to right, all bits following the first zero must also be zero DSCP Diffserv Code Point value(DSCP): It can be specific value, range of value or 'Any'. DSCP values are in the range 0-63 including BE, CS1-CS7, EF or AF11-AF43

IP Fragment IPv4 frame fragmented option: yes|no|any

Sport Source TCP/UDP port:(0-65535) or 'Any', specific or port range applicable for IP protocol UDP/TCP

Dport Destination TCP/UDP port:(0-65535) or 'Any', specific or port range applicable for IP protocol UDP/TCP

6. IPv6: Protocol IP protocol number: (0-255, TCP or UDP) or 'Any' Source IP IPv6 source address: (a.b.c.d) or 'Any', 32 LS bits

DSCP Diffserv Code Point value(DSCP): It can be specific value, range of value or 'Any'. DSCP values are in the range 0-63 including BE, CS1-CS7, EF or AF11-AF43

Sport Source TCP/UDP port:(0-65535) or 'Any', specific or port range applicable for IP protocol UDP/TCP

Dport Destination TCP/UDP port:(0-65535) or 'Any', specific or port range applicable for IP protocol UDP/TCP

Action Configuration:

Class QoS Class: "class (0-7)", default- basic classification

DP Valid DP Level can be (0-3)", default- basic classification

DSCP Valid dscp value can be (0-63, BE, CS1-CS7, EF or AF11-AF43)

Buttons:

Save – Click to save changes.

Reset – Click to undo any changes made locally and revert to previously saved values.

3.14.11 QCL Status

The section shows how to configure and display the QCL status

Each row describes the QCE that is defined. It is a conflict if a specific QCE is not applied to the hardware due to hardware limitations. The maximum number of QCEs is 256 on each switch.

Web Interface

To display the QoS Control List Status in the web interface:

1. Click Configuration, QoS, QCL Status
2. If you want to auto-refresh the information then you need to activate "Auto-refresh".
3. Select the combined, static, Voice VLAN and conflict.

4. Click the " Refresh " to refresh a entry of the MVR Statistics Information.

Figure 3-14.11: The QoS Control List Status

User	QCE#	Frame Type	Port	Action			Conflict
				Class	DP	DSCP	
Static	2	Any	2-4,7,8,10A-10B	Class 2	Default	Default	No
Static	1	Any	5-10B	Class 0	Default	Default	No

Parameter description:

User:

Indicates the QCL user.

QCE#

Indicates the index of QCE.

Frame Type:

Indicates the type of frame to look for incoming frames. Possible frame types are:

Any: The QCE will match all frame type.

Ethernet: Only Ethernet frames (with Ether Type 0x600-0xFFFF) are allowed.

LLC: Only (LLC) frames are allowed

LLC: Only (SNAP) frames are allowed.

IPv4: The QCE will match only IPV4 frames.

IPv6: The QCE will match only IPV6 frames.

Port:

Indicates the list of ports configured with the QCE.

Action:

Indicates the classification action taken on ingress frame if parameters configured are matched with the frame's content.

There are three action fields: Class, DPL and DSCP.

Class: Classified QoS Class; if a frame matches the QCE it will be put in the queue.

DPL: Drop Precedence Level; if a frame matches the QCE then DP level will set to value displayed under DPL column.

DSCP: If a frame matches the QCE then DSCP will be classified with the value displayed under DSCP column.

Conflict:

Displays QCE status. It may happen that resources required to add a QCE may not available, in that case it shows conflict status as 'Yes', otherwise it is always 'No'. Please note that conflict can be resolved by releasing the resource required by the QCE and pressing 'Refresh' button.

Auto-refresh:

Activate the auto-refresh to refresh the information automatically.

Resolve Conflict:

Click it to resolve the conflict issue.

Refresh:

Refresh the QCL information manually.

3.14.12 Storm Control

The section shows how to configure the Storm control of the switch. There is a unicast storm rate control, multicast storm rate control, and a broadcast storm rate control. These only affect flooded frames, i.e. frames with a (VLAN ID, DMAC) pair not present on the MAC Address table. The configuration indicates the permitted packet rate for unicast, multicast or broadcast traffic across the switch

Web Interface

To configure the Storm Control Configuration parameters in the web interface:

1. Click Configuration, QoS, Storm Control Configuration
2. Activate to select the frame type to enable storm control
3. Set the Rate Parameters
4. Click Save to save the setting
5. If you want to cancel the setting then you need to click the Reset button. It will revert to previously saved values

Figure 3-14.12: The Storm Control Configuration

Frame Type	Enable	Rate (pps)
Unicast	<input type="checkbox"/>	1
Multicast	<input type="checkbox"/>	1
Broadcast	<input type="checkbox"/>	1

Save Reset

Parameter description:

Frame Type:

The settings in a particular row apply to the frame type listed here: Unicast, Multicast or Broadcast.

Enable:

Enable or disable the storm control status for the given frame type.

Rate:

The rate unit is packets per second (pps). Valid values are: 1, 2, 4, 8, 16, 32, 64, 128, 256, 512, 1K, 2K, 4K, 8K, 16K, 32K, 64K, 128K, 256K, 512K or 1024K., 1024K, 2048K, 4096K, 8192K, 16384K or 32768K., 1024K, 2048K, 4096K, 8192K, 16384K or 32768K.

The 1 kpps is actually 1002.1 pps.

Buttons:

Save – Click to save changes.

Reset – Click to undo any changes made locally and revert to previously saved values.

3.14.13 WRED

The section shows how to configure the WRED function of the switch.

This page allows you to configure the Random Early Detection (RED) settings for queue 0 to 5.

RED cannot be applied to queue 6 and 7.

3 Configuration

Through different RED configuration for the queues (QoS classes) it is possible to obtain Weighted Random Early Detection (WRED) operation between queues.

The settings are global for all ports in the stack/switch.

To configure the WRED Configuration parameters in the web interface:

1. Click Configuration, WRED Configuration
2. Activate to select enable or disable WRED
3. Key-in each Parameter value.
4. Click Save to save the setting
5. If you want to cancel the setting then you need to click the Reset button. It will revert to previously saved values

Figure 3-14.13: The WRED Configuration

Queue	Enable	Min. Threshold	Max. DP 1	Max. DP 2	Max. DP 3
0	<input type="checkbox"/>	0	1	5	10
1	<input type="checkbox"/>	0	1	5	10
2	<input type="checkbox"/>	0	1	5	10
3	<input type="checkbox"/>	0	1	5	10
4	<input type="checkbox"/>	0	1	5	10
5	<input type="checkbox"/>	0	1	5	10

Save Reset

Parameter description:

Queue:

The queue number (QoS class) for which the configuration below applies.

Enable:

Activate to enable or disable the WRED function on the switch QoS Queue.

Min. Threshold:

Controls the lower RED threshold. If the average queue filling level is below this threshold, the drop probability is zero. This value is restricted to 0-100.

Max. DP1:

Controls the drop probability for frames marked with Drop Precedence Level 1 when the average queue filling level is 100%. This value is restricted to 0-100.

Max. DP2:

Controls the drop probability for frames marked with Drop Precedence Level 2 when the average queue filling level is 100%. This value is restricted to 0-100.

Max. DP3:

Controls the drop probability for frames marked with Drop Precedence Level 3 when the average queue filling level is 100%. This value is restricted to 0-100.

RED Drop Probability Function

The following illustration shows the drop probability function with associated parameters.

Max. DP 1-3 is the drop probability when the average queue filling level is 100%. Frames marked with Drop Precedence Level 0 are never dropped. Min. Threshold is the average queue filling level where the queues randomly start dropping frames. The drop probability for frames marked with Drop Precedence Level n increases

linearly from zero (at Min. Threshold average queue filling level) to Max. DP n (at 100% average queue filling level).

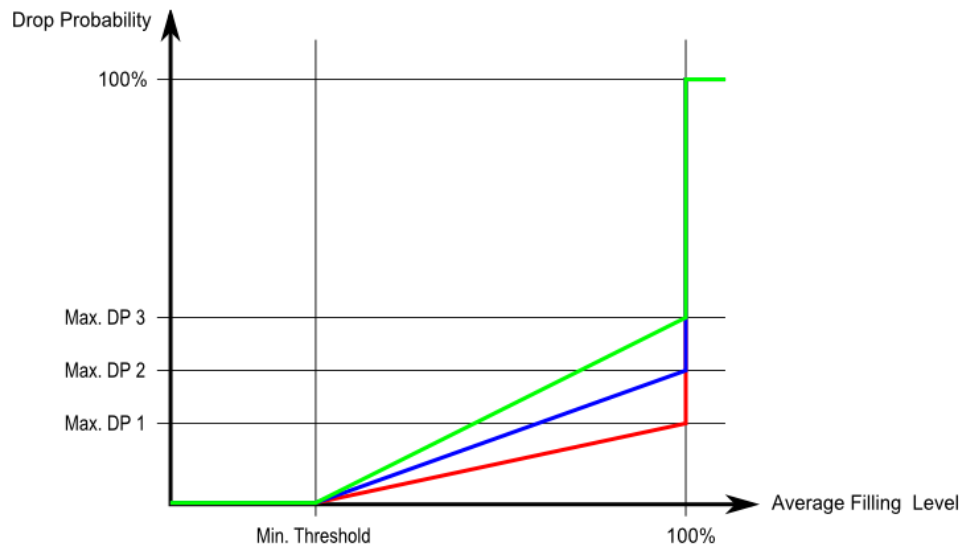

Buttons:

Save – Click to save changes.

Reset – Click to undo any changes made locally and revert to previously saved values.

3.15 Thermal Protection

The section allows the user to inspect and configure the current setting for controlling thermal protection. Thermal protection is used to protect the chip from getting overheated.

3.15.1 Configuration

Web Interface

To configure the Thermal Protection in the web interface:

1. Click Configuration, Thermal Protection, Configuration
2. Specify the temperature in the priority 0 to 3.
3. Select the priority per port.
4. Click "Apply" to save the setting.
5. Click "Reset" if you want to cancel the settings, they will revert to previously saved values.

Parameter description:

Temperature settings for priority groups

The temperature at which the ports with the corresponding priority will be turned off.

Port priorities

The priority the port belongs to.

3 Configuration

Thermal Protection Configuration

Temperature settings for priority groups

Priority	Temperature	
0	255	°C
1	255	°C
2	255	°C
3	255	°C

Port priorities

Port	Priority
*	<>
1	0
2	0
3	0

3.15.2 Status

The section allows the user to inspect the thermal status information related to thermal protection if thermal protection has been configured already.

Web Interface:

To display the Thermal Protection Status in the web interface:

1. Click Configuration, Thermal Protection, Status

Parameter description:

Chip Temperature Shows the current chip temperature in Celcius.

Port Status

Shows the current status of the port.

Thermal Protection Status

Local Port	Temperature	Port status
1	62 °C	Port link operating normally
2	62 °C	Port link operating normally
3	62 °C	Port link operating normally
4	62 °C	Port link operating normally
5	62 °C	Port link operating normally
6	62 °C	Port link operating normally
7	62 °C	Port link operating normally
8	62 °C	Port link operating normally

3.16 s-Flow Agent

The sFlow Collector configuration for the switch can be monitored and modified here. Up to 1 Collector is supported. This page allows for configuring sFlow collector IP type, sFlow collector IP Address, Port Number, for each sFlow Collector

3.16.1 Collector

The "Current " field displays the currently configured sFlow Collector. The "Configured" field displays the new Collector Configuration.

Web Interface

To configure the sFlow Agent in the web interface:

1. Click Configuration, sFlow Agent, Collector

2. Set the parameters
3. Scroll to IP Type to choice with IPv4 or IPv6
4. Click Save to save the setting
5. If you want to cancel the setting then you need to click the Reset button. It will revert to previously saved values.

Figure 3-15.1: The sFlow Collector Configuration

	Configured	Current
Receiver Id	1	1
IP Type	IPv4	IPv4
IP Address	0.0.0.0	0.0.0.0
Port	6343	6343
Time Out	0	0
Datagram Size	1400	1400

Save Reset

Parameter description:

Receiver Id:

The "Receiver ID" input fields allow the user to select the receiver ID. Indicates the ID of this particular sFlow Receiver. Currently one ID is supported as one collector is supported.

IP Type:

A drop down list to select the type of IP of Collector is displayed. By default, IPv4 is the type of Collector IP type. You could using IPv4 or IPv6.

IP Address:

The address of a reachable IP is to be entered into the text box.

This IP is used to monitor the sFlow samples sent by sFlow Agent(our switch).

By default, The IP is set to 0.0.0.0,and a new entry has to be added to it.

Port:

A port to listen to the sFlow Agent has to be configured for the Collector.

The value of the port number has to be typed into the text box.

The value accepted is within the range of 1-65535. But an appropriate port number not used by other protocols need to be configured. By default, the port's number is 6343

Time out:

It is the duration during which the collector receives samples, Once it is expired the sampler stops sending the samples. It is through the management the value is set before it expires. The value accepted is within the range of 0-2147483647. By default it is set to 0.

Datagram Size:

It is the maximum UDP datagram size to send out the sFlow samples to the receiver. The value accepted is within the range of 200-1500 bytes. The default is 1400 bytes.

Buttons:

Save – Click to save changes.

Reset – Click to undo any changes made locally and revert to previously saved values.

3.16.2 Sampler

This section shows how to configure the sFlow sampler to suit specific requirements. An average of 1 out of N packets/operations is randomly sampled, which results not in a 100% accurate result, but in a rather accurate approximation with quantifiable accuracy.

Web Interface

To configure the sFlow Agent in the web interface:















































1. Click Configuration, sFlow Agent, sampler
2. Click the  to edit the sFlow sampler parameters
3. Scroll to Sample Type to choice with None, Tx, Rx or All.
4. Click Save to save the setting
5. If you want to cancel the setting then you need to click the Reset button. It will revert to previously saved values

Figure 3-15.2: The sFlow sampler Configuration

sFlow Sampler Configuration						
sFlow Ports	sFlow Instance	Flow Sampling			Counter Sampling	
		Sampler Type	Sampling Rate	Max Hdr Size	Polling Interval	
1	1	None	0	128	0	
2	1	None	0	128	0	
3	1	None	0	128	0	
4	1	None	0	128	0	
5	1	None	0	128	0	
6	1	None	0	128	0	
7	1	None	0	128	0	
8	1	None	0	128	0	
9	1	None	0	128	0	
10	1	None	0	128	0	
11	1	None	0	128	0	
12	1	None	0	128	0	
13	1	None	0	128	0	
14	1	None	0	128	0	
15	1	None	0	128	0	
16	1	None	0	128	0	
17	1	None	0	128	0	
18	1	None	0	128	0	
19	1	None	0	128	0	
20	1	None	0	128	0	
21	1	None	0	128	0	
22	1	None	0	128	0	
23	1	None	0	128	0	
24	1	None	0	128	0	
25	1	None	0	128	0	
26	1	None	0	128	0	
27	1	None	0	128	0	
28	1	None	0	128	0	
29	1	None	0	128	0	
30	1	None	0	128	0	
31	1	None	0	128	0	
32	1	None	0	128	0	
33	1	None	0	128	0	
34	1	None	0	128	0	
35	1	None	0	128	0	
36	1	None	0	128	0	
37	1	None	0	128	0	
38	1	None	0	128	0	
39	1	None	0	128	0	
40	1	None	0	128	0	
41	1	None	0	128	0	
42	1	None	0	128	0	
43	1	None	0	128	0	
44	1	None	0	128	0	
45	1	None	0	128	0	
46	1	None	0	128	0	
47	1	None	0	128	0	
48	1	None	0	128	0	
49	1	None	0	128	0	
50	1	None	0	128	0	
51	1	None	0	128	0	
52	1	None	0	128	0	

sFlow Sampler Configuration	
sFlow Port	1
sFlow Instance	1
Sampler Type	None 
Sampling Rate	0
Max Hdr Size	128
Polling Interval	0
<input type="button" value="Save"/> <input type="button" value="Reset"/> <input type="button" value="Cancel"/>	

Parameter description:

sFlow Ports:

List of the port numbers on which sFlow is configured.

sFlow Instance:

Configured sFlow instance for the port number.

Sampler Type:

Configured sampler type on the port and could be any of the types: None, Rx, Tx or All. You can scroll to choice one for your sampler type.

By default, The value is "None".

Sampling Rate:

Configured sampling rate on the ports.

Max Hdr Size:

Configured size of the header of the sampled frame.

Polling Interval:

Configured polling interval for the counter sampling.

Buttons:

 - Edits the Data source sampler configuration.

Save – Click to save changes.

Reset – Click to undo any changes made locally and revert to previously saved values.

Cancel - Click to cancel your changes.

Auto-refresh:

Activate the auto-refresh to refresh the information automatically.

Refresh:

Refresh the sFlow Sampler information manually.

3.17 Loop Protection

The loop Protection is used to detect the presence of traffic. When the switch receives packets (looping detection frame) with a MAC address equal to its own, the Loop Protection will take action. The port will be locked when it receives the looping Protection frames.

3.17.1 Configuration

The section describes how to configure Loop Protection.

Web Interface

To configure the Loop Protection parameters in the web interface:

1. Click Configuration, Loop Protection, Configuration
2. Activate to select enable or disable the port loop Protection.
3. Click Save to save the setting

3 Configuration

4. If you want to cancel the setting then you need to click the Reset button. It will revert to previously saved values

Figure 3-18.1: The Loop Protection Configuration.

Global Configuration			
Enable Loop Protection	Disable		
Transmission Time	5	seconds	
Shutdown Time	180	seconds	

Port	Enable	Action	Tx Mode
*	<input checked="" type="checkbox"/>	<>	<>
1	<input checked="" type="checkbox"/>	Shutdown Port	Enable
2	<input checked="" type="checkbox"/>	Shutdown Port	Enable
3	<input checked="" type="checkbox"/>	Shutdown Port	Enable
50	<input checked="" type="checkbox"/>	Shutdown Port	Enable
51	<input checked="" type="checkbox"/>	Shutdown Port	Enable
52	<input checked="" type="checkbox"/>	Shutdown Port	Enable

Save Reset

Parameter description:

General Settings:

Enable Loop Protection:

Controls whether loop protections is enabled (as a whole).

Transmission Time:

The interval between each loop protection PDU sent on each port. valid values are 1 to 10 seconds.

Shutdown Time:

The period (in seconds) for which a port will be kept disabled in the event of a loop is detected (and the port action shuts down the port). Valid values are 0 to 604800 seconds (7 days). A value of zero will keep a port disabled (until next device restart).

Port Configuration:

Port:

The switch port number of the port

Enable:

Controls whether loop protection is enabled on this switch port.

Action:

Configures the action performed when a loop is detected on a port. Valid values are Shutdown Port, Shutdown Port and Log or Log Only.

TX Mode:

Controls whether the port is actively generating loop protection PDU's, or whether it is just passively looking for looped PDU's.

Buttons:

Save – Click to save changes.

Reset – Click to undo any changes made locally and revert to previously saved values.

3.17.2 Status

This page displays the loop protection port status of the ports of the currently selected switch Web Interface

To configure the Loop Protection parameters in the web interface:

1. Click Configuration, Loop Protection, Status
2. Activate the Auto-refresh or click to refresh the Loop protection Port status manually.

Figure 3-18.2: The Loop Protection Status.

Loop Protection Status						
Port	Action	Transmit	Loops	Status	Loop	Time of Last Loop
1	Shutdown	Enabled	0	Up	-	-
2	Shutdown	Enabled	0	Down	-	-
3	Shutdown	Enabled	0	Down	-	-
50	Shutdown	Enabled	0	Down	-	-
51	Shutdown	Enabled	0	Down	-	-
52	Shutdown	Enabled	0	Down	-	-

Parameter description:

Port:

The switch port number of the logical port.

Action:

The currently configured port action.

Transmit:

The currently configured port transmit mode.

Loops:

The number of loops detected on this port.

Status:

The current loop protection status of the port.

Loop:

Whether a loop is currently detected on the port.

Time of Last Loop:

The time of the last loop event detected.

Auto-refresh:

Activate the auto-refresh to refresh the information automatically.

Refresh:

Refresh the Loop Protection information manually.

3.18 Easy Port

Easy Port provides a convenient way to save and share common configurations. You can use it to enable features and settings based on the location of a switch in the network and for mass configuration deployments across the network.

3 Configuration

You could easily implement included Voice IP phone, Wireless Access Point and IP Camera... etc. Others you can leverage configuration to run a converged voice, video, and data network considering quality of service (QoS), bandwidth, latency, and high performance.

Web Interface

To configure the Easy Port in the web interface:

1. Click Configuration, Easy Port.
2. Set the parameters
3. Scroll to Role for what kind device you want to set on the Easy Port and connect to.
4. Click Save to save the setting
5. If you want to cancel the setting then you need to click the Reset button. It will revert to previously saved values.

Figure 3-19.1: The Easy Port Configuration

Easy Port Configuration																															
													Port Members																		
1	2	3	4	5	6	7	8	9	10	11	12	13	14																		
<input type="checkbox"/>	<input type="checkbox"/>	<input type="checkbox"/>	<input type="checkbox"/>	<input type="checkbox"/>	<input type="checkbox"/>	<input type="checkbox"/>	<input type="checkbox"/>	<input type="checkbox"/>	<input type="checkbox"/>	<input type="checkbox"/>	<input type="checkbox"/>	<input type="checkbox"/>	<input type="checkbox"/>																		
Role IP-Phone <input type="text"/>																															
<table border="1"> <tr> <td>Access VLAN</td> <td>1</td> </tr> <tr> <td>VLAN Mode</td> <td>Hybrid</td> </tr> <tr> <td>Voice VLAN</td> <td>1000</td> </tr> <tr> <td>Traffic Class</td> <td>7(High)</td> </tr> <tr> <td>Port Security</td> <td>Enable</td> </tr> <tr> <td>Port Security Action</td> <td>Trep</td> </tr> <tr> <td>Port Security Limit</td> <td>1</td> </tr> <tr> <td>Spanning Tree Admin Edge</td> <td>Enable</td> </tr> <tr> <td>Spanning Tree BPDU Guard</td> <td>Enable</td> </tr> </table>														Access VLAN	1	VLAN Mode	Hybrid	Voice VLAN	1000	Traffic Class	7(High)	Port Security	Enable	Port Security Action	Trep	Port Security Limit	1	Spanning Tree Admin Edge	Enable	Spanning Tree BPDU Guard	Enable
Access VLAN	1																														
VLAN Mode	Hybrid																														
Voice VLAN	1000																														
Traffic Class	7(High)																														
Port Security	Enable																														
Port Security Action	Trep																														
Port Security Limit	1																														
Spanning Tree Admin Edge	Enable																														
Spanning Tree BPDU Guard	Enable																														
<input type="button" value="Apply"/> <input type="button" value="Reset"/>																															

Parameter description:

Port Members:

To activate which Port wants to enable the Easy Port function.

Role:

To scroll to select what kind device you want to connect and implement with the Easy Port setting.

Access VLAN:

To set the Access VLAN ID, it means the switch port access VLAN ID (AVID).

VLAN Mode:

To scroll to select the VLAN mode with Access, Trunk or Hybrid.

Voice VLAN:

If you connect the IP Phone you need to assign the Voice VLAN ID.

The value of the port number has to be typed into the text box.

Traffic Class:

To scroll to select the traffic class for the data stream priority. The available value from 0 (Low) to 7 (High). If you want the voice has high priority then you can set the value with 7.

Port Security:

To scroll to enable or disable the Port Security function on the Port. If you turn on the function then you need to set Port Security limit to allow how many device can access the port (via MAC address).

Port Security Action:

To scroll to select when the device wasn't allow to access then switch action as trap, shutdown or trap & shutdown.

Port Security limit:

To set the Port security limit, the default is 1.

Port Security limit:

To set the Port security limit (It means you can set how many device MAC address will allow to access the port), the default is 1.

Spanning Tree Admin Edge:

To scroll to enable or disable the Spanning Tree Admin Edge function on the Easy Port.

Spanning Tree BPDU Guard:

To scroll to enable or disable the Spanning Tree BPDU Guard function on the Easy Port.

Buttons:

Save – Click to save changes.

Reset – Click to undo any changes made locally and revert to previously saved values.

3.19 Mirroring

You can mirror traffic from any source port to a target port for real-time analysis. You can then attach a logic analyzer or RMON probe to the target port and study the traffic crossing the source port in a completely unobtrusive manner.

Mirror Configuration is used to monitor the traffic of the network. For example, we assume that Port A and Port B are Monitoring Port and Monitored Port respectively, thus, the traffic received by Port B will be copied to Port A for monitoring.

Web Interface

To configure the Mirror in the web interface:

1. Click Configuration, Mirroring
2. Select Port to mirror on which port
3. Scroll to disabled, enable, TX Only and RX Only to set the Port mirror mode
4. Click Save to save the setting
5. If you want to cancel the setting then you need to click the Reset button. It will revert to previously saved values.

Figure 3-20.1: The Mirror Configuration

Port	Mode
*	<>
1	Disabled
2	Disabled
3	Disabled
50	Disabled
51	Disabled
52	Disabled

Parameter description:

Port to mirror on:

Port to mirror also known as the mirror port. Frames from ports that have either source (rx) or destination (tx) mirroring enabled are mirrored on this port. Disabled disables mirroring.

Mirror Port Configuration

The following table is used for Rx and Tx enabling.

Port:

The logical port for the settings contained in the same row.

Mode:

Select mirror mode.

Rx only Frames received on this port are mirrored on the mirror port. Frames transmitted are not mirrored.

Tx only Frames transmitted on this port are mirrored on the mirror port. Frames received are not mirrored.

Disabled Neither frames transmitted nor frames received are mirrored.

Enabled Frames received and frames transmitted are mirrored on the mirror port.

 For a given port, a frame is only transmitted once. It is therefore not possible to mirror Tx frames on the mirror port. Because of this, mode for the selected mirror port is limited to Disabled or Rx only.

Buttons:

Save – Click to save changes.

Reset – Click to undo any changes made locally and revert to previously saved values.

3.20 Trap Event Severity

The function is used to send an Alarm trap and get the Event log. The Trap Events Configuration function is used to enable the switch to send out the trap information when pre-defined trap events occur.

Web Interface

To configure the Trap Event Severity in the web interface:

1. Click Configuration, Trap Event Severity Configuration
2. Select the Group name and Severity Level
3. Click Save to save the setting
4. If you want to cancel the setting then you need to click the Reset button. It will revert to previously saved values.

Figure 3-21.1: The Trap Event Severity Configuration

Group Name	Severity Level
ACL	Info
ACL Log	Debug
Access Mgmt	Info
Auth Failed	Warning
Cold Start	Warning
Config Info	Info
Firmware Upgrade	Info
Import Export	Info
LACP	Info
Link Status	Warning
Login	Info
Logout	Info
Mgmt IP Change	Info
Module Change	Notice
NAS	Info
Passwd Change	Info
Port Security	Info
Thermal Protect	Info
VLAN	Info
Warm Start	Warning

Save Reset

Parameter description:

Group Name:

The field describe the Trap Event definition.

Severity Level:

To scroll to select the event type with “Emerg, Alert, Crit, Error, Warning, Notice, Info and Debug”.

Buttons:

Save – Click to save changes.

Reset – Click to undo any changes made locally and revert to previously saved values.

3.21 SMTP Configuration

The function, is used to set a Alarm trap when the switch alarm then you could set the SMTP server to send you the alarm mail.

Web Interface

To configure the SMTP in the web interface:

1. Click Configuration, SMTP Configuration
2. Select the Severity Level
3. Specify the parameters in each blank field.
4. Click Save to save the setting
5. If you want to cancel the setting then you need to click the Reset button. It will revert to previously saved values.

Figure 3-22.1: The SMTP Configuration

SMTP Configuration	
Mail Server	<input type="text"/>
User Name	<input type="text"/>
Password	<input type="password"/>
Serverity Level	Info <input type="button" value="v"/>
Sender	<input type="text"/>
Return Path	<input type="text"/>
Email Address 1	<input type="text"/>
Email Address 2	<input type="text"/>
Email Address 3	<input type="text"/>
Email Address 4	<input type="text"/>
Email Address 5	<input type="text"/>
Email Address 6	<input type="text"/>

Parameter description:

These parameters are displayed on the SMTP Configuration page:

Mail Server:

Specify the IP Address of the server transferring your email.

Username:

Specify the username on the mail server.

Password:

Specify the password on the mail server.

Sender:

To set the mail sender name.

Return-Path:

To set the mail return-path as sender mail address.

Email Address 1-6:

Email address that would like to receive the alarm message.

Buttons:

Save – Click to save changes.

Reset – Click to undo any changes made locally and revert to previously saved values.

3.22 UPnP

UPnP is an acronym for Universal Plug and Play. The goals of UPnP are to allow devices to connect seamlessly and to simplify the implementation of networks in the home (data sharing, communications, and entertainment) and in corporate environments for simplified installation of computer components

Web Interface

To configure the UPnP in the web interface:

1. Click Configuration, UPnP

2. Select the mode to enable or disable
3. Specify the parameters in each blank field.
4. Click Save to save the setting
5. If you want to cancel the setting then you need to click the Reset button. It will revert to previously saved values.

Figure 3-23.1: The UPnP Configuration

UPnP Configuration	
Mode	Disabled ▾
TTL	4
Advertising Duration	100
<input type="button" value="Save"/> <input type="button" value="Reset"/>	

Parameter description:

These parameters are displayed on the UPnP Configuration page:

Mode:

Indicates the UPnP operation mode. Possible modes are:

Enabled: Enable UPnP mode operation.

Disabled: Disable UPnP mode operation.

When the mode is enabled, two ACEs are added automatically to trap UPnP related packets to CPU. The ACEs are automatically removed when the mode is disabled.

TTL:

The TTL value is used by UPnP to send SSDP advertisement messages. Valid values are in the range 1 to 255.

Advertising Duration:

The duration, carried in SSDP packets, is used to inform a control point or control points how often it or they should receive an SSDP advertisement message from this switch. If a control point does not receive any message within the duration, it will think that the switch no longer exists. Due to the unreliable nature of UDP, in the standard it is recommended that such refreshing of advertisements to be done at less than one-half of the advertising duration. In the implementation, the switch sends SSDP messages periodically at the interval one-half of the advertising duration minus 30 seconds. Valid values are in the range 100 to 86400.

Buttons:

Save – Click to save changes.

Reset – Click to undo any changes made locally and revert to previously saved values.

4 System Configuration

This chapter describes the entire basic configuration tasks which includes the System Information and any managing of the switch (e.g. time, account, IP, syslog and SNMP).

4.1 System Information

After you login, the switch shows you the system information. This page tells you the basic information of the system, including "Model Name", "System Description", "Contact", "Device Name", "System Up Time", "BIOS Version", "Firmware Version", "Hardware-Mechanical Version", "Serial Number", "Host IP Address", "Host Mac Address", "Device Port", "RAM Size", and "Flash Size".

4.1.1 Information

The switch system information is provided here.

To access the System Information in the web interface:

1. Click SYSTEM, System, and Information.
2. Specify the contact information for the system administrator as well as the name and location of the switch. Also indicate the local time zone by configuring the appropriate offset.
3. Click Refresh

Figure 2-1.1: System Information (eg GS-2352)

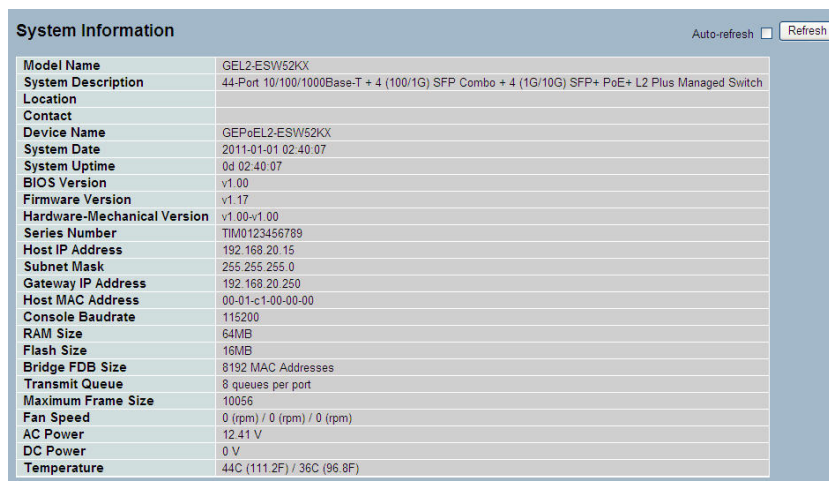

System Information	
Model Name	GEL2-ESW52KX
System Description	44-Port 10/100/1000Base-T + 4 (100/1G) SFP Combo + 4 (1G/10G) SFP+ PoE+ L2 Plus Managed Switch
Location	
Contact	
Device Name	GEPoEL2-ESW52KX
System Date	2011-01-01 02:40:07
System Uptime	0d 02:40:07
BIOS Version	v1.00
Firmware Version	v1.17
Hardware-Mechanical Version	v1.00-v1.00
Series Number	TIM0123456789
Host IP Address	192.168.20.15
Subnet Mask	255.255.255.0
Gateway IP Address	192.168.20.250
Host MAC Address	00-01-c1-00-00-00
Console Baudrate	115200
RAM Size	64MB
Flash Size	16MB
Bridge FDB Size	8192 MAC Addresses
Transmit Queue	8 queues per port
Maximum Frame Size	10056
Fan Speed	0 (rpm) / 0 (rpm) / 0 (rpm)
AC Power	12.41 V
DC Power	0 V
Temperature	44C (111.2F) / 36C (96.8F)

Parameter description:

Model name:

The model name of this device.

System description:

The description of the device. In this case: "44-Port 10/100/1000Base-T + 4 (100/1G) SFP Combo + 4 (1G/10G) SFP+ PoE+ L2 Plus Managed Switch".

Location:

The physical location of the switch. User-defined.

Contact:

For easy managing and maintenance of the device, you may enter the name of a contact person and a phone number here. You can configure this parameter through the device's user interface or SNMP.

Device name:

The name of the switch. User-defined.

System Date:

Shows the system time of the switch. Its format: day of week, month, day, hours: minutes: seconds, year.

System up time:

The time accumulated since this switch has been powered up. Its format is day, hour, minute, second.

BIOS version:

The version of the BIOS in the switch.

Firmware version:

The firmware version in the switch.

Hardware-Mechanical version:

The version of the electronic and the mechanical hardware. The figure before the hyphen shows the version of electronic hardware; the one after the hyphen show the version of mechanical hardware.

Serial number:

The serial number of the switch.

Host IP address:

The IP address of the switch.

Host MAC address:

The ethernet MAC address of the management agent in the switch.

Device Port:

Shows all types and numbers of the port in the switch.

RAM size:

The size of the RAM in the switch.

Flash size:

The size of the flash memory in the switch.

Bridge FDB size:

Displays the bridge FDB size information.

Transmit Queue:

Displays the transmit hardware priority queue information.

Maximum Frame size:

Displays the maximum frame size information.

4.1.2 Configuration

You can identify the system by configuring the contact information, name, and location of the switch.

4 System Configuration

Web interface

To configure the System Information in the web interface:

1. Click System, System Information, Configuration.
2. Enter System Contact, System Name, System Location.
3. Click Save

Figure 2-1.2: System Information configuration



System Information Configuration	
System Contact	<input type="text"/>
System Name	<input type="text" value="GEPoEL2-ESW52KX"/>
System Location	<input type="text"/>
<input type="button" value="Save"/> <input type="button" value="Reset"/>	

Parameter description:

System Contact:

The textual identification of the contact person for this managed node, together with information on how to contact this person. The allowed string length is 0 to 255, and the allowed content is the ASCII characters from 32 to 126.

System Name:

An administratively assigned name for this managed node. By convention, this is the node's fully-qualified domain name. A domain name is a text string drawn from the alphabet (A-Za-z), digits (0-9), minus sign (-). No space characters are permitted as part of a name. The first character must be an alpha character. And the first or last character must not be a minus sign. The allowed string length is 0 to 255.

System Location:

The physical location of this node (e.g., telephone closet, 3rd floor). The allowed string length is 0 to 255, and the allowed content is the ASCII characters from 32 to 126.

4.1.3 CPU Load

This page displays the CPU load, using an SVG graph. The load is measured as averaged over the last 100ms, 1sec and 10 seconds intervals. The last 120 samples are graphed, and the last numbers are displayed as text as well. In order to display the SVG graph, your browser must support the SVG format. Consult the SVG Wiki for more information on browser support. Specifically, at the time of writing, Microsoft Internet Explorer will need to have a plugin installed to support SVG.

Web interface

To configure System Information in the web interface:

1. Click System, System Information, CPU Load.
2. Display the CPU Load on the screen
3. Click Auto-refresh.

Figure 2-1.3: CPU Load

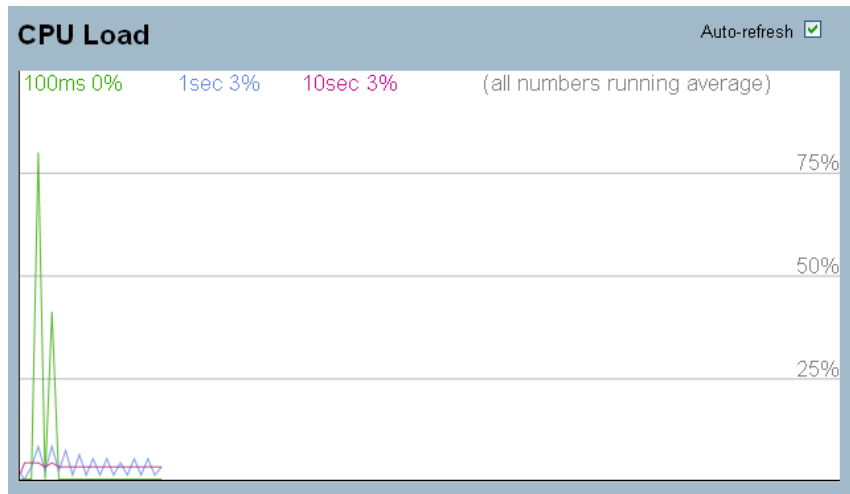

Parameter description:

Auto-refresh

Activate the auto-refresh to refresh the log automatically.

4.2 Time

This page configures the switch's time. Local Time Configuration and NTP Configuration is supported.

4.2.1 Manual

The switch provides manual and automatic ways to set the system time via NTP. Manual setting is simple and you just enter "Year", "Month", "Day", "Hour", "Minute" and "Second" within the valid value range indicated in each item.

Web Interface

To configure Time in the web interface:

1. Click Time, Manual.
2. Specify the time parameters.
3. Click Save.

Figure 2-2.1: The time configuration

Time Configuration	
Clock Source:	<input checked="" type="radio"/> Use Local Settings <input type="radio"/> Use NTP Server
Local Time:	2011-01-01 00:10:20 YYYY-MM-DD HH:MM:SS
Time Zone Offset:	0 min
Daylight Savings	<input type="checkbox"/> Enable
Time Set Offset:	60 min. (Range: 1 - 1440, Default: 60)
Daylight Savings Type:	<input type="radio"/> By dates <input type="radio"/> Recurring
From:	YYYY-MM-DD HH:MM
To:	YYYY-MM-DD HH:MM
From:	Day: Sun Week: First Month: Jan Time: 00:00 HH:MM
To:	Day: Sun Week: First Month: Jan Time: 00:00 HH:MM
<input type="button" value="Save"/> <input type="button" value="Reset"/>	

Parameter description:

Clock Source:

Select which clock source is used for the GS-2300 series. You can select "Use local Settings" or "Use NTP Server" as the switches' time clock source.

Local Time:

Shows the current time of the system.

Time Zone Offset:

Provides the time zone offset relative to UTC/GMT. The offset is given in minutes east of GMT. The valid range is from -720 to 720 minutes

Daylight Saving:

Daylight saving is adopted in some countries. If set, it will adjust the time according to the starting date and the ending date by the given amount. For example, you set the day light saving to be 1 hour. When the time passes over the starting time, the system time will be increased by one hour after one minute. When the time passes over the ending time, the system time will be decreased one hour after one minute.

The switch supports a configurable day light saving time offset of up to 24 hours. The zero for this parameter means it need not have to adjust current time, equivalent to in-act daylight saving. If you set daylight saving to be non-zero, you have to set the starting/ending date as well; otherwise, the daylight saving function will not be activated.

Time Set Offset:

Provide the Daylight saving time set offset. The offset is given in minutes east of GMT. The valid range is from 1 to 1440 minutes. default is 60 min

Daylight Savings Type:

Provide the Daylight savings type selection. You can select " By Dates" or "Recurring" two type for Daylight saving type.

From:

To configure Daylight saving start date and time, the format is "YYYY-MM-DD HH:MM".

To:

To configure Daylight saving end date and time, the format is "YYYY-MM-DD HH:MM".

4.2.2 NTP

NTP, the Network Time Protocol is used to sync the network time based on Greenwich Mean Time (GMT). You can use the built-in NTP time server or manually specify a user-defined NTP server as well as a Time Zone, the switch will sync the time shortly after pressing the <Apply> button. Though it synchronizes the time automatically, NTP does not update the time periodically without user's processing.

The Time Zone is an offset time off GMT. You have to select the time zone first and then perform time sync via NTP because the switch will combine the time zone offset and updated NTP time to provide the local time, otherwise, you will not able to get the correct time. The switch supports configurable time zone from -12 to +13 hours in steps of 1 hour.

Default Time zone: +8 Hrs.

Web Interface

To configure NTP in the web interface:

1. Click SYSTEM, NTP.
2. Specify the NTP parameters.
3. Click Save.

Figure 2-2.2: The NTP configuration

The screenshot shows a web interface titled "NTP Configuration". It contains five input fields, each labeled "Server 1" through "Server 5". Below these fields are two buttons: "Save" and "Reset".

Parameter description:

Server 1 to 5:

The NTP's IPv4 or IPv6 address. The IPv6 address in 128-bit records is represented as eight fields of up to four hexadecimal digits with a colon separating each field (:). For example, 'fe80::215:c5ff:fe03:4dc7'. The symbol '::' is a special syntax that can be used as a shorthand way of representing multiple 16-bit groups of contiguous zeros; but it can only appear once. It can also represent a legally valid IPv4 address. For example, '::192.1.2.34'.

Buttons

Save – Click to save changes.

Reset - Click to undo any changes made locally and revert to previously saved values.

4.3 Account

Only administrators can create, modify or delete usernames and passwords. Administrators can modify other guest identities' password without confirming the password except it is necessary to modify an administrator-equivalent identity. Guest-equivalent identities can modify their passwords only. Please note that you must select administrator/guest identity in the field of Authorization in advance before configuring the username and password. Only one administrator is allowed to exist and unable to be deleted. In addition, up to 4 guest accounts can be created.

4.3.1 Users

This page provides an overview of the current users. Currently the only way to login as another user on the web server is to close and reopen the browser.

Web Interface

To configure accounts in the web interface:

Click SYSTEM, Account, Users.

Click Add new user

Specify the User Name parameter.

Click Save.

Figure2- 3.1: The Users Account configuration

The screenshot shows two parts of the web interface. The top part is titled 'Users Configuration' and contains a table with two columns: 'User Name' and 'Privilege Level'. The table has one row with 'admin' in the 'User Name' column and '15' in the 'Privilege Level' column. Below the table is a button labeled 'Add new user'. The bottom part is titled 'Add User' and contains a form with the following fields: 'User Name' (text input), 'Password' (password input), 'Password (again)' (password input), and 'Privilege Level' (dropdown menu with '1' selected). At the bottom of the form are three buttons: 'Save', 'Reset', and 'Cancel'.

Parameter description:

User Name:

The name identifying the user. This is also a link to Add/Edit User.

Password

The password associated with the account. The allowed string length is 0 to 255, and the allowed content is the ASCII characters from 32 to 126.

Password (again)

You must type the same password again in this field.

Privilege Level:

The privilege level of the user. The allowed range is 1 to 15. If the privilege level value is 15, he can access all groups, i.e. he is granted the fully control of the device. But others value need to refer to each group privilege level. User's privilege should be same or greater than the group privilege level to have the access of that group. By default settings, most groups with privilege level 5 have the read-only access and with privilege level 10 have the read-write access. And the system maintenance (software upload, factory defaults and etc.) need user privilege level 15. Generally, the privilege level 15 can be used for an administrator account, privilege level 10 for a standard user account and privilege level 5 for a guest account.

4.3.2 Privilege Level

This page provides an overview of the privilege levels. The switch provides user set privilege levels from 1 to 15 for Account, Aggregation, Diagnostics, EEE, GARP, GVRP, IP, ICMP Snooping, LACP, LLDP, LLDP, MED, MAC Table, MRP, MVR, MVRP, Maintenance Mirroring, POE Ports, Private VLANs, QoS, SMTP, SNMP, Security, Spanning Tree, System Trap Event, VCL, VLANs, Voice VLAN.

Web Interface

To configure Privilege Level in the web interface:

1. Click SYSTEM, Account, Privilege Level.
2. Specify the Privilege parameter.
3. Click Save.

Figure2- 3.2: The Privilege Level configuration

Group Name	Privilege Levels
Account	10
Aggregation	10
Diagnostics	10
EEE	10
Easyport	10
GARP	10
GVRP	10
IP	10
IPMC Snooping	10
LACP	10
LLDP	10
LLDP MED	10
Loop Detection	10
MAC Table	10
MRP	10
MVR	10
MVRP	10
Maintenance	15
Mirroring	10
POE	10
Ports	10
Private VLANs	10
QoS	10
SFlow	10
SMTP	10
SNMP	10
Security	10
Spanning Tree	10
System	10
Trap Event	10
VCL	10
VLANs	10
Voice VLAN	10

Save Reset

Parameter description:

Group Name

The name identifying the privilege group. In most cases, a privilege level group consists of a single module (e.g. LACP, RSTP or QoS), but a few of them contain more than one. The following description defines the privilege level groups in details:

System: Contact, Name, Location, Time zone, Log.

Security: Authentication, System Access Management, Port (contains Dot1x port, MAC based and the MAC Address Limit), ACL, HTTPS, SSH, ARP Inspection and IP source guard.

IP: Everything except 'ping'.

Port: Everything except 'VeriPHY'.

Diagnostics: 'ping' and 'VeriPHY'.

Maintenance: System Reboot, System Restore Default, System Password, Configuration Save, Configuration Load and Firmware Load. Web- Users, Privilege Levels and everything in Maintenance.

Privilege Levels

Every group has an authorization privilege level for the following sub groups: configuration read-only, configuration/execute read-write, status/statistics read-only, status/statistics read-write (e.g. for clearing of statistics). User privilege should be equal or greater than the authorization Privilege level to have the access to that group.

4.4 IP

IP is an acronym for Internet Protocol. It is a protocol used for communicating data across an internet network.

IP is a "best effort" system, which means that no packet of information sent over is assured to reach its destination in the same condition it was sent. Each device connected to a Local Area Network (LAN) or Wide Area Network (WAN) is given an Internet Protocol address, and this IP address is used to identify the device uniquely among all other devices connected to the extended network.

The current version of the Internet protocol is IPv4, which has 32-bits Internet Protocol addresses allowing for in excess of four billion unique addresses. This number is reduced drastically by the practice of webmasters taking addresses in large blocks, the bulk of which remain unused. The new version of the Internet Protocol, IPv6, which has 128-bits Internet Protocol addresses. This number can be represented roughly by a three with thirty-nine zeroes after it.

4.4.1 IPv4

The IPv4 address for the switch could be obtained via DHCP Server for VLAN 1. To manually configure an address, you need to change the switch's default settings to values that are compatible with your network. You may also need to establish a default gateway between the switch and management stations that exist on another network segment.

Web Interface

To configure an IP address in the web interface:

1. Click System, IP Configuration.
2. Specify the IPv4 settings, and enable DNS proxy service if required.
3. Click Save.

The Configured column is used to view or change the IP configuration.

The Current column is used to show the active IP configuration.

Figure2- 4.1: The IP configuration

IP Configuration

	Configured	Current
DHCP Client	<input type="checkbox"/>	<input type="button" value="Renew"/>
IP Address	192.168.1.1	192.168.1.1
IP Mask	255.255.255.0	255.255.255.0
IP Router	0.0.0.0	0.0.0.0
VLAN ID	1	1
DNS Server	0.0.0.0	0.0.0.0

IP DNS Proxy Configuration

DNS Proxy

Parameter description:

DHCP Client:

Enable the DHCP client by checking this box. If DHCP fails and the configured IP address is zero, DHCP will retry. If DHCP fails and the configured IP address is non-zero, DHCP will stop and the configured IP settings will be used. The DHCP client will announce the configured System Name as hostname to provide DNS lookup.

IP Address:

Provide the IP address of this switch in dotted decimal notation.

IP Mask:

Provide the IP mask of this switch dotted decimal notation.

IP Router:

Provide the IP address of the router in dotted decimal notation.

SNTP Server:

Provide the IP address of the SNTP Server in dotted decimal notation.

DNS Server:

Provide the IP address of the DNS Server in dotted decimal notation.

VLAN ID:

Provide the managed VLAN ID. The allowed range is 1 to 4095.

DNS Proxy:

When DNS proxy is enabled, DUT will relay DNS requests to the current configured DNS server on DUT, and reply as a DNS resolver to the client device on the network.

4.4.2 IPv6

This section describes how to configure the switches' IPv6 information.

Web Interface

To configure IPv6 on the switch in the web interface:

1. Click System, IPv6 Configuration.
2. Specify the IPv6 settings, and enable Auto Configuration service if required.
3. Click Save.

The 'Configured' column is used to view or change the IPv6 configuration.

The 'Current' column is used to show the active IPv6 configuration.

Figure2- 4.2: The IPv6 configuration

IPv6 Configuration		
	Configured	Current
Auto Configuration	<input type="checkbox"/>	<input type="button" value="Renew"/>
Address	<input type="text" value="::192.168.1.1"/>	<input type="text" value="::192.168.1.1"/> Link-Local Address: fe80::240:c7ff:fe74:d1
Prefix	<input type="text" value="96"/>	<input type="text" value="96"/>
Gateway	<input type="text" value="::"/>	<input type="text" value="::"/>
<input type="button" value="Save"/> <input type="button" value="Reset"/>		

Parameter description:

Auto Configuration:

Enable IPv6 auto-configuration by checking this box. If it fails, the configured IPv6 address is zero. The router may delay responding to a router solicitation for a few seconds, the total time needed to complete auto-configuration can be significantly longer.

Address:

Provide the IPv6 address of this switch. IPv6 address is in 128-bit records represented as eight fields of up to four hexadecimal digits with a colon separating each field (:). For example, 'fe80::215:c5ff:fe03:4dc7'. The symbol '::' is a special syntax that can be used as a shorthand way of representing multiple 16-bit groups of contiguous zeros; but it can only appear once. It can also represent a legally valid IPv4 address. For example, '::192.1.2.34'.

Prefix:

Provide the IPv6 Prefix of this switch. The allowed range is 1 to 128.

Router

Provide the IPv6 gateway address of this switch. IPv6 address is in 128-bit records represented as eight fields of up to four hexadecimal digits with a colon separating each field (:). For example, 'fe80::215:c5ff:fe03:4dc7'. The symbol '::' is a special syntax that can be used as a shorthand way of representing multiple 16-bit groups of contiguous zeros; but it can only appear once. It can also represent a legally valid IPv4 address. For example, '::192.1.2.34'.

4.5 Syslog

The Syslog is a standard for logging program messages. It allows separation of the software that generates messages from the system that stores them and the software that reports and analyzes them. It can be used as generalized informational, analysis and debugging messages. It is supported by a wide variety of devices and receivers across multiple platforms.

4.5.1 Configuration

This section describes how to configure the system log and provide a wide variety of devices and receivers across multiple platforms.

Web Interface

To configure Syslog in the web interface:

1. Click SYSTEM, Syslog.

2. Specify the syslog parameters includes IP Address of Syslog server and Port number.
3. Activate the Syslog to enable it.
4. Click Save.

Figure2- 5.1: The System Log configuration

Parameter description:

Server Mode:

Indicates the server mode. When the mode operation is enabled, the syslog message will be sent out to a syslog server. The syslog protocol is based on UDP communication and received on UDP port 514 and the syslog server will not send acknowledgments back to the sender since UDP is a connectionless protocol and it does not provide acknowledgments. The syslog packet will always be send out even if the syslog server does not exist. Possible modes are:

Enabled: Enable server mode operation.

Disabled: Disable server mode operation.

Server Address 1 and 2:

Indicates the IPv4 host address of the syslog server 1 and server 2 (For redundancy). If the switch provides DNS, it also can be a host name.

Syslog Level:

Indicates what kind of message will send to the syslog server. Possible modes are:

Info: Send information, warnings and errors.

Warning: Send warnings and errors.

Error: Send errors.

4.5.2 Log

This section describes the system log information of the switch

Web Interface

To display the log configuration in the web interface:

1. Click Syslog, Log.
2. Display the log information.

Figure2- 5.2: The System Log configuration

System Log Information Auto-refresh Refresh Clear << << >> >>|

Level All

The total number of entries is 10 for the given level.

Start from ID 1 with 20 entries per page.

ID	Level	Time	Message
1	Info	-	Switch just made a cold boot.
2	Info	1970-01-01 00:00:05	Link up on port 1
3	Info	1970-01-01 00:26:08	Link down on port 1
4	Info	1970-01-01 00:55:53	Link up on port 1
5	Info	1970-01-01 01:47:14	Link down on port 1
6	Info	1970-01-01 01:48:36	Link up on port 1
7	Info	1970-01-01 02:20:04	Link down on port 1
8	Info	1970-01-01 18:55:49	Link up on port 1
9	Info	1970-01-01 19:58:11	Link down on port 1
10	Info	1970-01-01 19:58:45	Link up on port 1

Parameter description:

Auto-refresh

Activate the auto-refresh to refresh the log automatically.

Level

Level of the system log entry. The following level types are supported:

Information: Information level of the system log.

Warning: Warning level of the system log.

Error: Error level of the system log. All: All levels.

ID

ID (≥ 1) of the system log entry.

Time

The time of the system log entry.

Message

The message of the system log entry.

Refresh

Refresh the system log manually.

Clear

Clear the system log manually.

4.5.3 Detailed Log

This section describes the detailed log information of the switch.

Web Interface

To display the detailed log configuration in the web interface:

1. Click Syslog, Detailed Log.
2. Display the log information.

Figure2- 5.3: The Detailed System Log Information

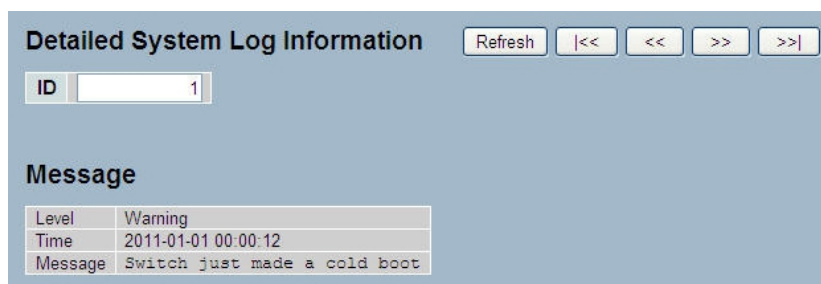

Parameter description:

ID

The ID (≥ 1) of the system log entry.

Message

The detailed message of the system log entry.

Refresh

Refresh the system log manually.

Clear

Clear the system log manually.

4.6 SNMP

Any Network Management System (NMS) running the Simple Network Management Protocol (SNMP) can manage the Managed devices equipped with SNMP agent, provided that the Management Information Base (MIB) is installed correctly on the managed devices. The SNMP is a protocol that is used to govern the transfer of information between SNMP manager and agent and traverses the Object Identity (OID) of the management Information Base (MIB), described in the form of SMI syntax. SNMP agent is running on the switch to response the request issued by SNMP manager.

Basically, it is passive except issuing the trap information. The switch supports a switch to turn on or off the SNMP agent. If you set the field SNMP "Enable", the SNMP agent will be started up. All supported MIB OIDs, including RMON MIB, can be accessed via SNMP manager. If the field SNMP is set "Disable", SNMP agent will be de-activated, the related Community Name, Trap Host IP Address, Trap and all MIB counters will be ignored.

4.6.1 System

This section describes how to configure SNMP on the switch. This function is used to configure SNMP settings, community name, trap host and public traps as well as the throttle of SNMP. An SNMP manager must pass the authentication by identifying both community names, then it can access the MIB information of the target device. So, both parties must have the same community name. Once completing the setting, click <Apply> button, for the setting to take effect.

Web Interface

To configure the SNMP System in the web interface:

1. Click SNMP, System.
2. Activate SNMP State to enable or disable the SNMP function.
3. Specify the Engine ID
4. Click Apply.

Figure2- 6.1: The SNMP System Configuration

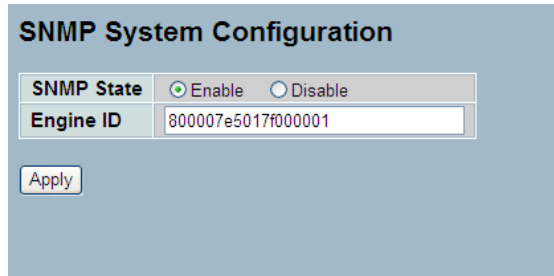

SNMP System Configuration

SNMP State: Enable Disable

Engine ID:

Parameter description:

These parameters are displayed on the SNMP System Configuration page:

SNMP State:

Enable: Enable SNMP operation.

Disable: Disable SNMP operation.

Default: Enable.

Engine ID:

SNMPv3 engine ID. Syntax: 0-9,a-f,A-F, min 5 octet, max 32 octet, fifth octet must not be 00. If the Engine ID is changed it will clear all original users.

4.6.2 Communities

The function is used to configure SNMPv3 communities. The Community and UserName is unique. To create a new community account, please click on the <Add new community> button, and enter the account information and click on <Save>. Max Group Number: 4.

Web Interface

To configure SNMP Communities in the web interface:

1. Click SNMP, Communities.
2. Click Add new community.
3. Specify the SNMP communities parameters.
4. Click Save.
5. If you want to modify or clear the setting click Reset.

Figure2- 6.2: The SNMPv1/v2 Communities Security Configuration



SNMPv1/v2 Communities to Security Configuration

Delete	Community	UserName	Source IP	Source Mask
<input type="checkbox"/>	public	<input type="text"/>	0.0.0.0	0.0.0.0
<input type="checkbox"/>	private	<input type="text"/>	0.0.0.0	0.0.0.0

SNMPv1/v2 Communities to Security Configuration

Delete	Community	User Name	Source IP	Source Mask
<input type="button" value="Delete"/>	<input type="text"/>	<input type="text"/>	0.0.0.0	0.0.0.0

Parameter description:

Delete

Delete the entry. It will be deleted during the next save.

Community

Indicates the community access string to permit access to SNMPv3 agent. The allowed string length is 1 to 32, and the allowed content is ASCII characters from 33 to 126. The community string will be treated as security name and map a SNMPv1 or SNMPv2c community string.

UserName:

The UserName access string to permit access to the SNMPv3 agent. The length of the "UserName" string is restricted to 1-32 characters.

Source IP

Indicates the SNMP access source address. A particular range of source addresses can be used to restrict the source subnet when combined with source mask.

Source Mask

Indicates the SNMP access source address mask

4.6.3 Users

The function is used to configure SNMPv3 users. The Entry index key is UserName. To create a new UserName account, please click on the <Add new user> button, and enter the user information then click <Save>. Max Group Number: 10.

Web Interface

To configure SNMP Users in the web interface:

1. Click SNMP, Users.
2. Specify the Privilege parameter.
3. Click Save.

Figure 2-6.3: The SNMP Users Configuration

SNMPv3 Users Configuration

Delete	User Name	Security Level	Authentication Protocol	Authentication Password	Privacy Protocol	Privacy Password
<input type="checkbox"/>	default_user	NoAuth, NoPriv	None	None	None	None

SNMPv3 Users Configuration						
Delete	User Name	Security Level	Authentication Protocol	Authentication Password	Privacy Protocol	Privacy Password
<input type="checkbox"/>	<input type="text"/>	Auth, Priv	MD5	<input type="text"/>	DES	<input type="text"/>
<input type="button" value="Add new user"/>		<input type="button" value="Save"/>				

Parameter description:

Delete

Check to delete the entry. It will be deleted during the next save.

User Name

A string identifying the user name that this entry should belong to. The allowed string length is 1 to 32, and the allowed content is ASCII characters from 33 to 126.

Security Level

Indicates the security model that this entry should belong to. Possible security models are:

NoAuth, NoPriv: No authentication and no privacy.

Auth, NoPriv: Authentication and no privacy.

Auth, Priv: Authentication and privacy.

The value of the security level cannot be modified if an entry already exists. That means it must first be ensured that the value is set correctly.

Authentication Protocol

Indicates the authentication protocol that this entry should belong to. Possible authentication protocols are:

None: No authentication protocol.

MD5: An optional flag to indicate that this user uses MD5 authentication protocol.

SHA: An optional flag to indicate that this user uses SHA authentication protocol.

The value of the security level cannot be modified if an entry already exists. That means must first ensure that the value is set correctly.

Authentication Password

A string identifying the authentication password phrase. For MD5 authentication protocol, the allowed string length is 8 to 32. For SHA authentication protocol, the allowed string length is 8 to 40. The allowed content is ASCII characters from 33 to 126.

Privacy Protocol

Indicates the privacy protocol that this entry should belong to. Possible privacy protocols are:

None: No privacy protocol.

DES: An optional flag to indicate that this user uses DES authentication protocol.

Privacy Password

A string identifying the privacy password phrase. The allowed string length is 8 to 32, and the allowed content is ASCII characters from 33 to 126.

4.6.4 Groups

The function is used to configure SNMPv3 groups. The Entry index keys are Security Model and Security Name. To create a new group account, please check <Add new group> button, and enter the group information then check <Save>. Max Group Number: v1: 2, v2: 2, v3:10.

Web Interface

To configure SNMP Groups in the web interface:

1. Click SNMP, Groups.
2. Specify the Privilege parameter.
3. Click Save.

Figure 2-6.4: The SNMP Groups Configuration

SNMPv3 Groups Configuration

Delete	Security Model	Security Name	Group Name
<input type="checkbox"/>	v1	public	default_ro_group
<input type="checkbox"/>	v1	private	default_rw_group
<input type="checkbox"/>	v2c	public	default_ro_group
<input type="checkbox"/>	v2c	private	default_rw_group
<input type="checkbox"/>	usm	default_user	default_rw_group

SNMPv3 Groups Configuration

Delete	Security Model	Security Name	Group Name
<input type="button" value="Delete"/>	v1	125323	

Parameter description:

Delete

Delete the entry. It will be deleted during the next save.

Security Model

Indicates the security model that this entry should belong to. Possible security models are:

v1: Reserved for SNMPv1.

v2c: Reserved for SNMPv2c.

usm: User-based Security Model (USM).

Security Name

A string identifying the security name that this entry should belong to. The allowed string length is 1 to 32, and the allowed content is ASCII characters from 33 to 126.

Group Name

A string identifying the group name that this entry should belong to. The allowed string length is 1 to 32, and the allowed content is ASCII characters from 33 to 126.

4.6.5 Views

The function is used to configure SNMPv3 view. The entries index keys are OID Subtree and View Name. To create a new view account, please click the <Add new view> button, and enter the view information then click <Save>. Max group number: 28.

Configure SNMPv3 view table on this page. The entry index keys are View Name and OID Subtree.

Web Interface

1. Click SNMP, Views.
2. Click Add new view.
3. Specify the SNMP View parameters.
4. Click Save.
5. If you want to modify or clear the setting then click Reset.

Figure 2-6.5: The SNMP Views Configuration

The figure shows two screenshots of the 'SNMPv3 Views Configuration' web interface. The top screenshot displays a table with the following data:

Delete	View Name	View Type	OID Subtree
<input type="checkbox"/>	default_view	included	.1

Below the table are two buttons: 'Add new view' and 'Save'.

The bottom screenshot shows the same interface but with the 'Add new view' button highlighted with a dashed border, indicating it is the active element.

Parameter description:

Delete

Delete the entry. It will be deleted during the next save.

View Name

A string identifying the view name that this entry should belong to. The allowed string length is 1 to 32, and the allowed content is ASCII characters from 33 to 126.

View Type

Indicates the view type that this entry should belong to. Possible view types are:

included: An optional flag to indicate that this view subtree should be included.

excluded: An optional flag to indicate that this view subtree should be excluded.

In general, if a view entry's view type is 'excluded', there should be another view entry existing with view type as 'included' and it's OID subtree should overstep the 'excluded' view entry.

OID Subtree

The OID defining the root of the subtree to add to the named view. The allowed OID length is 1 to 128. The allowed string content is digital number or asterisk(*).

Save

Save the configuration to the ROM.

4.6.6 Access

The function is used to configure SNMPv3 accesses. The entries index keys are Group Name, Security Model and Security level. To create a new access account, please click the <Add new access> button, and enter the access information. Then click <Save>. Max group number: 14

Web Interface

To configure SNMP access in the web interface:

1. Click SNMP, Accesses.
2. Click Add new Access.
3. Specify the SNMP Access parameters.
4. Click Save.
5. If you want to modify or clear the setting then click Reset.

Figure 2-6.6: The SNMP Accesses Configuration

SNMPv3 Accesses Configuration

Delete	Group Name	Security Model	Security Level	Read View Name	Write View Name
<input type="checkbox"/>	default_ro_group	any	NoAuth, NoPriv	default_view	None
<input type="checkbox"/>	default_rw_group	any	NoAuth, NoPriv	default_view	default_view

SNMPv3 Accesses Configuration

Delete	Group Name	Security Model	Security Level	Read View Name	Write View Name
<input type="button" value="Delete"/>	3533	any	NoAuth, NoPriv	None	None

Parameter description:

Delete

Check to delete the entry. It will be deleted during the next save.

Group Name

A string identifying the group name that this entry should belong to. The allowed string length is 1 to 32, and the allowed content is ASCII characters from 33 to 126.

Security Model

Indicates the security model that this entry should belong to. Possible security models are:

any: Any security model accepted(v1|v2c|usm).

v1: Reserved for SNMPv1.

v2c: Reserved for SNMPv2c.

usm: User-based Security Model (USM).

Security Level

Indicates the security model that this entry should belong to. Possible security models are:

NoAuth, NoPriv: No authentication and no privacy.

Auth, NoPriv: Authentication and no privacy.

Auth, Priv: Authentication and privacy.

Read View Name

The name of the MIB view defining the MIB objects for which this request may request the current values. The allowed string length is 1 to 32, and the allowed content is ASCII characters from 33 to 126.

Write View Name

The name of the MIB view defining the MIB objects for which this request may potentially set new values. The allowed string length is 1 to 32, and the allowed content is ASCII characters from 33 to 126.

4.6.7 Trap

The function is used to configure SNMP traps. To create a new trap account, please click on the <No number> button, and enter the trap information then click <Apply>. Max group number: 6.

Web Interface

To configure SNMP Traps:

1. Click SNMP, Trap.
2. Display the SNMP Trap Hosts information table.
3. Choose an entry to display and modify the detail parameters or click the delete button to delete the entry.

Figure 2-6.7: The SNMP Trap Host Configuration

Trap Hosts Configuration

Delete	No	Version	Server IP	UDP Port	Community/Security Name	Severity Level	Security Level	Authentication Protocol	Privacy Protocol
	1								
	2								
	3								
	4								
	5								
	6								

Save

Trap Host Configuration

Trap Version	v2c
Server IP	0.0.0.0
UDP Port	162
Community/Security Name	
Severity Level	Info
Security Level	NoAuth, NoPriv
Authentication Protocol	MD5
Authentication Password	
Privacy Protocol	DES
Privacy Password	

Save Reset

Parameters description:

Delete:

Check <Delete> entry then click the <Save> button, the entry will be deleted.

Trap Version:

You may choose v1, v2c or v3 trap.

Server IP:

Used SNMP Host IP address.

UDP Port:

Used Port number. Default: 162

Community / Security Name:

The length of "Community / Security Name" string is restricted to 1-32.

Security Level:

Indicates what kind of message will send to Security Level.

Possible modes are:

Info: Send information, warnings and errors.

Warning: Send warnings and errors.

Error: Send errors.

Security Level:

There are three kinds of choices.

NoAuth, NoPriv: No authentication and no privacy.

Auth, NoPriv: Authentication and no privacy.

Auth, Priv: Authentication and privacy.

Authentication Protocol:

You can choose MD5 or SHA for authentication.

Authentication Password:

The length of 'MD5 Authentication Password' is restricted to 8 – 32.

The length of 'SHA Authentication Password' is restricted to 8 – 40.

Privacy Protocol:

You can set DES encryption for UserName.

Privacy Password:

The length of 'Privacy Password' is restricted to 8 – 32.

5 Security

This chapter describes all of the switch security configuration tasks to enhance the security of local network including IP Source Guard, ARP Inspection, DHCP Snooping, AAA, etc.

5.1 IP Source Guard

The section describes how to configure the IP Source Guard detail parameters of the switch. The IP Source Guard configuration can be used to enable or disable ports of the switch.

5.1.1 Configuration

This section describes how to configure IP Source Guard setting including:

Mode (Enabled and Disabled)

Maximum Dynamic Clients (0, 1, 2, Unlimited)

To configure an IP Source Guard in the web interface:

1. Select "Enabled" in the Mode of IP Source Guard Configuration.
2. Select "Enabled" of the specific port in the Mode of Port Mode Configuration.
3. Select Maximum Dynamic Clients (0, 1, 2, Unlimited) of the specific port in the Mode of Port Mode Configuration.
4. Click Save.

Figure 4-1.1: The IP Source Guard Configuration

IP Source Guard Configuration

Mode: Disabled

Translate dynamic to static

Port Mode Configuration

Port	Mode	Max Dynamic Clients
*	<>	<>
1	Disabled	Unlimited
2	Disabled	Unlimited
3	Disabled	Unlimited
50	Disabled	Unlimited
51	Disabled	Unlimited
52	Disabled	Unlimited

Save Reset

Parameter description:

Mode of IP Source Guard Configuration:

Enable the Global IP Source Guard or disable the Global IP Source Guard. All configured ACEs will be lost when the mode is enabled.

Port Mode Configuration:

Specify IP Source Guard is enabled on which ports. Only when both Global Mode and Port Mode on a given port are enabled, IP Source Guard is enabled on this given port.

Max Dynamic Clients:

Specify the maximum number of dynamic clients that can be learned on given port. This value can be 0, 1, 2 or unlimited. If the port mode is enabled and the value of max dynamic client is equal to 0, it means only allow the IP packets forwarding that are matched in static entries on the specific port.

Buttons:

Save – Click to save changes.

Reset – Click to undo any changes made locally and revert to previously saved values.

5.1.2 Static Table

The section describes how to configure the Static IP Source Guard Table parameters of the switch. You could use the Static IP Source Guard Table configure to manage the entries.

Web Interface

To configure a Static IP Source Guard Table in the web interface:

1. Click "Add new entry".
2. Specify the Port, VLAN ID, IP Address, and MAC address in the entry.
3. Click Save.

Figure 4-1.2: The Static IP Source Guard Table

Static IP Source Guard Table

Delete	Port	VLAN ID	IP Address	MAC address
Delete	1			

Buttons: Add new entry, Save, Reset

Parameter description:

Delete:

Delete the entry. It will be deleted during the next save.

Port:

The logical port for the settings.

VLAN ID:

The vlan id for the settings.

5 Security

IP Address:

Allowed source IP address.

IP Mask:

It can be used for calculating the allowed network with IP address.

MAC address:

Allowed source MAC address.

Add new entry:

Click to add a new entry to the Static IP Source Guard table. Specify the Port, VLAN ID, IP address, and IP Mask for the new entry. Click "Save".

Buttons:

Save – Click to save changes.

Reset – Click to undo any changes made locally and revert to previously saved values.

5.1.3 Dynamic Table

The section describes how to configure the Dynamic IP Source Guard Table parameters of the switch.

Web Interface

To configure a Dynamic IP Source Guard Table in the web interface:

1. Specify the Start from port, VLAN ID, IP Address, and entry per page.
2. Check "Auto-refresh".

Figure 4-1.3: The Dynamic Table

Dynamic IP Source Guard Table Auto-refresh Refresh |<< >>

Start from Port 1, VLAN 1 and IP address 0.0.0.0 with 20 entries per page.

Port	VLAN ID	IP Address	MAC Address
No more entries			

Parameter description:

Port:

Related switch port.

VLAN ID:

VLAN ID in which the IP traffic is permitted.

IP Address:

User IP address.

MAC Address:

Source MAC address.

Auto-refresh:

Activate the auto-refresh to refresh the information automatically.

Refresh:

Refresh the Dynamic IP Source Guard Table manually.

|<<, >>:

Go to previous/next page or entry.

5.2 ARP Inspection

The section describes how to configure the ARP Inspection parameters of the switch.

5.2.1 Configuration

This section describes how to configure ARP Inspection including:

Mode (Enabled and Disabled)

Port (Enabled and Disabled)

To configure ARP Inspection in the web interface:

1. Select "Enabled" in the Mode of ARP Inspection Configuration.
2. Select "Enabled" of the specific port in the Mode of Port Mode Configuration.
3. Click Save.

Figure 4-2.1: The ARP Inspection Configuration

ARP Inspection Configuration

Mode: Disabled

Translate dynamic to static

Port Mode Configuration

Port	Mode
*	<>
1	Disabled
2	Disabled
3	Disabled
50	Disabled
51	Disabled
52	Disabled

Save Reset

Parameter description:

Mode of ARP Inspection Configuration:

Enable the Global ARP Inspection or disable the Global ARP Inspection.

Port Mode Configuration:

ARP Inspection is enabled on selected ports. Only when both Global Mode and Port Mode on a given port are enabled, ARP Inspection is enabled on this given port.

Buttons:

Save – Click to save changes.

Reset – Click to undo any changes made locally and revert to previously saved values.

5.2.2 Static Table

The section describes how to configure the Static ARP Inspection Table parameters of the switch.

To configure a Static ARP Inspection Table in the web interface:

1. Click "Add new entry".
2. Specify the Port, VLAN ID, IP Address, and MAC address in the entry.
3. Click Save.

Figure 4-2.2: The Static ARP Inspection Table

The figure consists of two screenshots of the 'Static ARP Inspection Table' configuration page. The top screenshot shows the header 'Static ARP Inspection Table' and a table with columns: Delete, Port, VLAN ID, MAC Address, and IP Address. Below the table is an 'Add new entry' button and 'Save' and 'Reset' buttons. The bottom screenshot shows the same interface but with one entry in the table. The entry has a 'Delete' button, a 'Port' dropdown menu set to '1', and empty input fields for 'VLAN ID', 'MAC Address', and 'IP Address'. The 'Add new entry' button is highlighted with a dashed border.

Parameter description:

Delete:

Delete the entry. It will be deleted during the next save.

Port:

The logical port for the settings.

VLAN ID:

The vlan id for the settings.

MAC Address:

Allowed Source MAC address in ARP request packets.

IP Address:

Allowed Source IP address in ARP request packets.

Adding new entry:

Click to add a new entry to the Static ARP Inspection table. Specify the Port, VLAN ID, MAC address, and IP address for the new entry. Click "Save".

Buttons:

Save – Click to save changes.

Reset – Click to undo any changes made locally and revert to previously saved values.

5.2.3 Dynamic Table

The section describes how to configure the Dynamic ARP Inspection Table parameters of the switch. The Dynamic ARP Inspection Table contains up to 1024 entries, and is sorted first by port, then by VLAN ID, then by MAC address, and then by IP address.

To configure a Dynamic ARP Inspection Table Configuration in the web interface:

1. Specify the Start from port, VLAN ID, MAC Address, IP Address, and entry per page.
2. Check "Auto-refresh".

Figure 4-2.3: The Dynamic ARP Inspection Table

Parameter description:

Port:

Switch Port Number for which the entries are displayed.

VLAN ID:

VLAN-ID in which the ARP traffic is permitted.

MAC Address:

User MAC address of the entry.

IP Address:

User IP address of the entry.

Auto-refresh:

Activate the auto-refresh to refresh the information automatically.

Refresh:

Refresh the Dynamic ARP Inspection Table manually

<<, >>:

Go to previous/next entry or page.

5.3 DHCP Snooping

The section describes how to configure the DHCP Snooping parameters of the switch. The DHCP Snooping can prevent attackers from adding their own DHCP servers to the network.

5.3.1 Configuration

This section describes how to configure DHCP Snooping setting including:

Snooping Mode (Enabled and Disabled)

Port Mode Configuration (Trusted, Untrusted)

To configure DHCP Snooping in the web interface:

1. Select "Enabled" in the Mode of DHCP Snooping Configuration.
2. Select "Trusted" of the specific port in the Mode of Port Mode Configuration.
3. Click Save.

Figure 4-3.1: The DHCP Snooping Configuration

DHCP Snooping Configuration

Snooping Mode: Disabled

Port Mode Configuration

Port	Mode
*	<>
1	Untrusted
2	Untrusted
3	Untrusted
50	Untrusted
51	Untrusted
52	Untrusted

Save Reset

Parameter description:

Snooping Mode:

Indicates the DHCP snooping mode operation. Possible modes are:

Enabled: Enable DHCP snooping mode operation. When DHCP snooping mode operation is enabled, the DHCP request messages will be forwarded to trusted ports and only allow reply packets from trusted ports.

Disabled: Disable DHCP snooping mode operation.

Port Mode:

Indicates the DHCP snooping port mode. Possible port modes are:

Trusted: Configures the port as trusted source of the DHCP messages.

Untrusted: Configures the port as untrusted source of the DHCP messages.

Buttons:

Save – Click to save changes.

Reset – Click to undo any changes made locally and revert to previously saved values.

5.3.2 Statistics

The section describes to show the DHCP Snooping Statistics information of the switch. The statistics shows only packet counters when DHCP snooping mode is enabled and relay mode is disabled. It doesn't count the DHCP packets for DHCP clients.

To configure a DHCP Snooping Statistics in the web interface:

1. Specify the Port which you want to monitor.
2. Check "Auto-refresh".

Figure 4-3.2: The DHCP Snooping Port Statistics

DHCP Snooping Port Statistics Port 1			
Receive Packets		Transmit Packets	
Rx Discover	0	Tx Discover	0
Rx Offer	0	Tx Offer	0
Rx Request	0	Tx Request	0
Rx Decline	0	Tx Decline	0
Rx ACK	0	Tx ACK	0
Rx NAK	0	Tx NAK	0
Rx Release	0	Tx Release	0
Rx Inform	0	Tx Inform	0
Rx Lease Query	0	Tx Lease Query	0
Rx Lease Unassigned	0	Tx Lease Unassigned	0
Rx Lease Unknown	0	Tx Lease Unknown	0
Rx Lease Active	0	Tx Lease Active	0

Parameter description:

Rx and Tx Discover:

The number of discover (option 53 with value 1) packets received and transmitted.

Rx and Tx Offer:

The number of offer (option 53 with value 2) packets received and transmitted.

Rx and Tx Request:

The number of request (option 53 with value 3) packets received and transmitted.

Rx and Tx Decline:

The number of decline (option 53 with value 4) packets received and transmitted.

Rx and Tx ACK:

The number of ACK (option 53 with value 5) packets received and transmitted.

Rx and Tx NAK:

The number of NAK (option 53 with value 6) packets received and transmitted.

Rx and Tx Release:

The number of release (option 53 with value 7) packets received and transmitted.

Rx and Tx Inform:

The number of inform (option 53 with value 8) packets received and transmitted.

Rx and Tx Lease Query:

The number of lease query (option 53 with value 10) packets received and transmitted.

Rx and Tx Lease Unassigned:

The number of lease unassigned (option 53 with value 11) packets received and transmitted.

Rx and Tx Lease Unknown:

The number of lease unknown (option 53 with value 12) packets received and transmitted.

Rx and Tx Lease Active:

The number of lease active (option 53 with value 13) packets received and transmitted.

Auto-refresh:

Activate the auto-refresh to refresh the information automatically.

Refresh:

Refresh the DHCP Snooping Port Statistics manually.

Clear:

Clear the entries.

5.4 DHCP Relay

The section describes how to forward DHCP requests to another specific DHCP servers via DHCP relay. The DHCP servers may be on another network.

5.4.1 Configuration

This section describes how to configure DHCP Relay setting including:

Relay Mode (Enabled and Disabled)

Relay Server IP setting

Relay Information Mode (Enabled and Disabled)

Relay Information Mode Policy (Replace, Keep and Drop)

To configure a DHCP Relay in the web interface:

1. Select "Enabled" in the Relay Mode of DHCP Relay Configuration.
2. Specify Relay Server IP address.
3. Select "Enabled" in the Relay Information Mode of DHCP Relay Configuration.
4. Specify Relay (Replace, Keep and Drop) in the Relay Information Mode of DHCP Relay Configuration.
5. Click Save.

Figure 4-4.1: The DHCP Relay Statistics

DHCP Relay Configuration	
Relay Mode	Disabled
Relay Server	0.0.0.0
Relay Information Mode	Disabled
Relay Information Policy	Replace

Save Reset

Parameter description:

Relay Mode:

Indicates the DHCP relay mode operation. Possible modes are:

Enabled: Enable DHCP relay mode operation. When DHCP relay mode operation is enabled, the agent forwards and transfers DHCP messages between the clients and the server when they are not in the same subnet domain. And the DHCP broadcast message won't be flooded for security considerations.

Disabled: Disable DHCP relay mode operation.

Relay Server:

Indicates the DHCP relay server IP address. A DHCP relay agent is used to forward and to transfer DHCP messages between the clients and the server when they are not in the same subnet domain.

Relay Information Mode:

Indicates the DHCP relay information mode operation. Possible modes are:

Enabled: Enable DHCP relay information mode operation. When DHCP relay information mode operation is enabled, the agent inserts specific information (option 82) into a DHCP message when forwarding to DHCP server and removes it from a DHCP message when transferring to DHCP client. It only works when DHCP relay operation mode is enabled.

Disabled: Disable DHCP relay information mode operation.

Relay Information Policy:

Indicates the DHCP relay information option policy. When DHCP relay information mode operation is enabled, if agent receives a DHCP message that already contains relay agent information it will enforce the policy. And it only works under DHCP if relay information operation mode is enabled. Possible policies are:

Replace: Replace the original relay information when a DHCP message that already contains it is received.

Keep: Keep the original relay information when a DHCP message that already contains it is received.

Drop: Drop the package when a DHCP message that already contains relay information is received.

Buttons:

Save – Click to save changes.

Reset – Click to undo any changes made locally and revert to previously saved values.

5.4.2 Statistics

The section describes to show the DHCP Relay Statistics information of the switch. The statistics show both of Server and Client packet counters when DHCP Relay mode is enabled.

Web Interface

To configure a DHCP Snooping Statistics in the web interface:

1. Check "Auto-refresh".

Figure 4-4.2: The DHCP Relay Statistics

DHCP Relay Statistics									
							Auto-refresh <input type="checkbox"/>	Refresh	Clear
Server Statistics									
Transmit to Server	Transmit Error	Receive from Server	Receive Missing Agent Option	Receive Missing Circuit ID	Receive Missing Remote ID	Receive Bad Circuit ID	Receive Bad Remote ID		
0	0	0	0	0	0	0	0		
Client Statistics									
Transmit to Client	Transmit Error	Receive from Client	Receive Agent Option	Replace Agent Option	Keep Agent Option	Drop Agent Option			
0	0	0	0	0	0	0			

Parameter description:

Transmit to Server:

The number of packets that are relayed from client to server.

Transmit Error:

The number of packets that resulted in errors while being sent to clients.

Receive from Server:

The number of packets received from server.

Receive Missing Agent Option:

5 Security

The number of packets received without agent information options.

Receive Missing Circuit ID:

The number of packets received with the Circuit ID option missing.

Receive Missing Remote ID:

The number of packets received with the Remote ID option missing.

Receive Bad Circuit ID:

The number of packets whose Circuit ID option did not match known circuit ID.

Receive Bad Remote ID:

The number of packets whose Remote ID option did not match known Remote ID.

Client Statistics

Transmit to Client:

The number of relayed packets from server to client.

Transmit Error:

The number of packets that resulted in error while being sent to servers.

Receive from Client:

The number of received packets from server.

Receive Agent Option:

The number of received packets with relay agent information option.

Replace Agent Option:

The number of packets which were replaced with relay agent information option.

Keep Agent Option:

The number of packets whose relay agent information was retained.

Drop Agent Option:

The number of packets that were dropped which were received with relay agent information.

Auto-refresh:

Activate the auto-refresh to refresh the information automatically.

Refresh:

Refresh the DHCP Relay Statistics manually.

Clear:

Clear the entries.

5.5 NAS

The section describes how to configure the NAS parameters of the switch. The NAS server can be employed to connect users to a variety of resources including Internet access, conference calls, printing documents on shared printers, or by simply logging on to the Internet.

5.5.1 Configuration

This section describes how to configure NAS according to IEEE 802.1X, MAC-based authentication system, and port settings. The NAS configuration consists of two sections, system- and port-wide.

To configure the Network Access Server in the web interface:

1. Select "Enabled" in the Mode of Network Access Server Configuration.
2. Check Reauthentication Enabled.
3. Set Reauthentication Period (Default is 3600 seconds).
4. Set EAPOL Timeout (Default is 30 seconds).
5. Set Aging Period (Default is 300 seconds).
6. Set Hold Time (Default is 10 seconds).
7. Check RADIUS-Assigned QoS Enabled.
8. Check RADIUS-Assigned VLAN Enabled.
9. Check Guest VLAN Enabled.
10. Specify Guest VLAN ID.
11. Specify Max. Reauth. Count.
12. Checked Allow Guest VLAN if EAPOL Seen.
13. Click Save.

Figure 4-5.1: The Network Access Server Configuration

Network Access Server Configuration

Refresh

System Configuration

Mode	Disabled
Reauthentication Enabled	<input type="checkbox"/>
Reauthentication Period	3600 seconds
EAPOL Timeout	30 seconds
Aging Period	300 seconds
Hold Time	10 seconds
RADIUS-Assigned QoS Enabled	<input type="checkbox"/>
RADIUS-Assigned VLAN Enabled	<input type="checkbox"/>
Guest VLAN Enabled	<input type="checkbox"/>
Guest VLAN ID	1
Max. Reauth. Count	2
Allow Guest VLAN if EAPOL Seen	<input type="checkbox"/>

Port Configuration

Port	Admin State	RADIUS-Assigned QoS Enabled	RADIUS-Assigned VLAN Enabled	Guest VLAN Enabled	Port State	Restart	
*	<>	<input type="checkbox"/>	<input type="checkbox"/>	<input type="checkbox"/>			
1	Force Authorized	<input type="checkbox"/>	<input type="checkbox"/>	<input type="checkbox"/>	Globally Disabled	Reauthenticate	Reinitialize
2	Force Authorized	<input type="checkbox"/>	<input type="checkbox"/>	<input type="checkbox"/>	Globally Disabled	Reauthenticate	Reinitialize
3	Force Authorized	<input type="checkbox"/>	<input type="checkbox"/>	<input type="checkbox"/>	Globally Disabled	Reauthenticate	Reinitialize
4	Force Authorized	<input type="checkbox"/>	<input type="checkbox"/>	<input type="checkbox"/>	Globally Disabled	Reauthenticate	Reinitialize
5	Force Authorized	<input type="checkbox"/>	<input type="checkbox"/>	<input type="checkbox"/>	Globally Disabled	Reauthenticate	Reinitialize
6	Force Authorized	<input type="checkbox"/>	<input type="checkbox"/>	<input type="checkbox"/>	Globally Disabled	Reauthenticate	Reinitialize
7	Force Authorized	<input type="checkbox"/>	<input type="checkbox"/>	<input type="checkbox"/>	Globally Disabled	Reauthenticate	Reinitialize
8	Force Authorized	<input type="checkbox"/>	<input type="checkbox"/>	<input type="checkbox"/>	Globally Disabled	Reauthenticate	Reinitialize
9	Force Authorized	<input type="checkbox"/>	<input type="checkbox"/>	<input type="checkbox"/>	Globally Disabled	Reauthenticate	Reinitialize
48	Force Authorized	<input type="checkbox"/>	<input type="checkbox"/>	<input type="checkbox"/>	Globally Disabled	Reauthenticate	Reinitialize
49	Force Authorized	<input type="checkbox"/>	<input type="checkbox"/>	<input type="checkbox"/>	Globally Disabled	Reauthenticate	Reinitialize
50	Force Authorized	<input type="checkbox"/>	<input type="checkbox"/>	<input type="checkbox"/>	Globally Disabled	Reauthenticate	Reinitialize
51	Force Authorized	<input type="checkbox"/>	<input type="checkbox"/>	<input type="checkbox"/>	Globally Disabled	Reauthenticate	Reinitialize
52	Force Authorized	<input type="checkbox"/>	<input type="checkbox"/>	<input type="checkbox"/>	Globally Disabled	Reauthenticate	Reinitialize

Save
Reset

Parameter description:

Mode:

Indicates if NAS is globally enabled or disabled on the switch. If globally disabled, all ports are allowed forwarding of frames.

Reauthentication Enabled:

If checked, successfully authenticated supplicants/clients are reauthenticated after the interval specified by the Reauthentication Period. Reauthentication for 802.1X-enabled ports can be used to detect if a new device is plugged into a switch port or if a supplicant is no longer attached.

For MAC-based ports, reauthentication is only useful if the RADIUS server configuration has changed. It does not involve communication between the switch and the client, and therefore doesn't imply that a client is still present on a port (see Aging Period below).

Reauthentication Period:

Determines the period, in seconds, after which a connected client must be reauthenticated. This is only active if the Reauthentication Enabled checkbox is checked. Valid values are in the range 1 to 3600 seconds.

EAPOL Timeout:

Determines the time for retransmission of Request Identity EAPOL frames.

Valid values are in the range 1 to 255 seconds. This has no effect for MAC-based ports.

Aging Period:

This setting applies to the following modes, i.e. modes using the Port Security functionality to secure MAC addresses:

- Single 802.1X
- Multi 802.1X
- MAC-Based Auth.

When the NAS module uses the Port Security module to secure MAC addresses, the Port Security module needs to check for activity on the MAC address in question at regular intervals and free resources if no activity is seen within a given period of time. This parameter controls exactly this period and can be set to a number between 10 and 1000000 seconds.

If reauthentication is enabled and the port is in an 802.1X-based mode, this is not so critical, since supplicants that are no longer attached to the port will get removed upon the next reauthentication, which will fail. But if reauthentication is not enabled, the only way to free resources is by aging the entries.

For ports in MAC-based Auth. mode, reauthentication doesn't cause direct communication between the switch and the client, so this will not detect whether the client is still attached or not, and the only way to free any resources is to age the entry.

Hold Time:

This setting applies to the following modes, i.e. modes using the Port Security functionality to secure MAC addresses:

- Single 802.1X
- Multi 802.1X
- MAC-Based Auth.

If a client is denied access - either because the RADIUS server denies the client access or because the RADIUS server request times out (according to the timeout specified on the "Configuration Security AAA" page) - the client is put on hold in the Unauthorized state. The hold timer does not count during an on-going authentication.

In MAC-based Auth. mode, the switch will ignore new frames coming from the client during the hold time.

The Hold Time can be set to a number between 10 and 1000000 seconds.

RADIUS-Assigned QoS Enabled:

RADIUS-assigned QoS provides a means to centrally control the traffic class to which traffic coming from a successfully authenticated supplicant is assigned on the switch. The RADIUS server must be configured to transmit special RADIUS attributes to take advantage of this feature (see RADIUS-Assigned QoS Enabled below for a detailed description)

The "RADIUS-Assigned QoS Enabled" checkbox provides a quick way to globally enable/disable RADIUS-server assigned QoS Class functionality. When checked, the individual ports' ditto setting determine whether RADIUS-assigned QoS Class is enabled on that port. When unchecked, RADIUS-server assigned QoS Class is disabled on all ports.

RADIUS-Assigned VLAN Enabled:

RADIUS-assigned VLAN provides a means to centrally control the VLAN on which a successfully authenticated supplicant is placed on the switch. Incoming traffic will be classified to and switched on the RADIUS-assigned VLAN. The RADIUS server must be configured to transmit special RADIUS attributes to take advantage of this feature (see RADIUS-Assigned VLAN Enabled below for a detailed description).

The "RADIUS-Assigned VLAN Enabled" checkbox provides a quick way to globally enable/disable RADIUS-server assigned VLAN functionality. When checked, the individual ports' ditto setting determine whether RADIUS-assigned VLAN is enabled on that port. When unchecked, RADIUS-server assigned VLAN is disabled on all ports.

Guest VLAN Enabled:

A Guest VLAN is a special VLAN - typically with limited network access - on which 802.1X-unaware clients are placed after a network administrator-defined timeout. The switch follows a set of rules for entering and leaving the Guest VLAN as listed below.

The "Guest VLAN Enabled" checkbox provides a quick way to globally enable/disable Guest VLAN functionality. When checked, the individual ports' ditto setting determines whether the port can be moved into Guest VLAN. When unchecked, the ability to move to the Guest VLAN is disabled on all ports.

Guest VLAN ID:

This is the value that a port's Port VLAN ID is set to if a port is moved into the Guest VLAN. It is only changeable if the Guest VLAN option is globally enabled.

Valid values are in the range [1; 4095].

Max. Reauth. Count:

The number of times the switch transmits an EAPOL Request Identity frame without response before considering entering the Guest VLAN is adjusted with this setting. The value can only be changed if the Guest VLAN option is globally enabled.

Valid values are in the range [1; 255].

Allow Guest VLAN if EAPOL Seen:

The switch remembers if an EAPOL frame has been received on the port for the life-time of the port. Once the switch considers whether to enter the Guest VLAN, it will first check if this option is enabled or disabled. If disabled (unchecked; default), the switch will only enter the Guest VLAN if an EAPOL frame has not been received on the port for the life-time of the port. If enabled (checked), the switch will consider entering the Guest VLAN even if an EAPOL frame has been received on the port for the life-time of the port.

The value can only be changed if the Guest VLAN option is globally enabled.

Port Configuration:

The table has one row for each port on the selected switch and a number of columns, which are:

Port:

The port number for which the configuration below applies.

Admin State:

If NAS is globally enabled, this selection controls the port's authentication mode. The following modes are available:

Force Authorized:

In this mode, the switch will send one EAPOL Success frame when the port link comes up, and any client on the port will be allowed network access without authentication.

Force Unauthorized:

In this mode, the switch will send one EAPOL Failure frame when the port link comes up, and any client on the port will be disallowed network access.

Port-based 802.1X:

In the 802.1X-world, the user is called the supplicant, the switch is the authenticator, and the RADIUS server is the authentication server. The authenticator acts as the man-in-the-middle, forwarding requests and responses between the supplicant and the authentication server. Frames sent between the supplicant and the switch are special 802.1X frames, known as EAPOL (EAP Over LANs) frames. EAPOL frames encapsulate EAP PDUs (RFC3748). Frames sent between the switch and the RADIUS server are RADIUS packets. RADIUS packets also encapsulate EAP PDUs together with other attributes like the switch's IP address, name, and the supplicant's port number on the switch. EAP is very flexible, in that it allows for different authentication methods, like MD5-Challenge, PEAP, and TLS. The important thing is that the authenticator (the switch) doesn't need to know which authentication method the supplicant and the authentication server are using, or how many information exchange frames are needed for a particular method. The switch simply encapsulates the EAP part of the frame into the relevant type (EAPOL or RADIUS) and forwards it.

When authentication is complete, the RADIUS server sends a special packet containing a success or failure indication. Besides forwarding this decision to the supplicant, the switch uses it to open up or block traffic on the switch port connected to the supplicant



Suppose two backend servers are enabled and that the server timeout is configured to X seconds (using the AAA configuration page), and suppose that the first server in the list is currently down (but not considered dead).

Now, if the supplicant retransmits EAPOL Start frames at a rate faster than X seconds, then it will never get authenticated, because the switch will cancel on-going backend authentication server requests whenever it receives a new EAPOL Start frame from the supplicant.

And since the server hasn't yet failed (because the X seconds haven't expired), the same server will be contacted upon the next backend authentication server request from the switch. This scenario will loop forever. Therefore, the server timeout should be smaller than the supplicant's EAPOL Start frame retransmission rate.

Single 802.1X:

In port-based 802.1X authentication, once a supplicant is successfully authenticated on a port, the whole port is opened for network traffic. This allows other clients connected to the port (for instance through a hub) to piggy-back on the successfully authenticated client and get network access even though they really aren't authenticated. To overcome this security breach, use the Single 802.1X variant. Single 802.1X is really not an IEEE standard, but features many of the same characteristics as does port-based 802.1X. In Single 802.1X, at most one supplicant can get authenticated on the port at a time. Normal EAPOL frames are used in the communication between the supplicant and the switch. If more than one supplicant is connected to a port, the one that comes first when the port's link comes up will be the first one considered. If that supplicant doesn't provide valid credentials within a certain amount of time, another supplicant will get a chance. Once a supplicant is successfully authenticated, only that supplicant will be allowed access. This is the most secure of all the supported modes. In this mode, the Port Security module is used to secure a supplicant's MAC address once successfully authenticated.

Multi 802.1X:

In port-based 802.1X authentication, once a supplicant is successfully authenticated on a port, the whole port is opened for network traffic. This allows other clients connected to the port (for instance through a hub) to piggy-back on the successfully authenticated client and get network access even though they really aren't authenticated. To overcome this security breach, use the Multi 802.1X variant.

Multi 802.1X is really not an IEEE standard, but features many of the same characteristics as does port-based 802.1X. Multi 802.1X is - like Single 802.1X - not an IEEE standard, but a variant that features many of the same characteristics. In Multi 802.1X, one or more supplicants can get authenticated on the same port at the same time. Each supplicant is authenticated individually and secured in the MAC table using the Port Security module.

In Multi 802.1X it is not possible to use the multicast BPDU MAC address as destination MAC address for EAPOL frames sent from the switch towards the supplicant, since that would cause all supplicants attached to the port to reply to requests sent from the switch. Instead, the switch uses the supplicant's MAC address, which is obtained from the first EAPOL Start or EAPOL Response Identity frame sent by the supplicant. An exception to this is when no supplicants are

attached. In this case, the switch sends EAPOL Request Identity frames using the BPDU multicast MAC address as destination - to wake up any supplicants that might be on the port.

The maximum number of supplicants that can be attached to a port can be limited using the Port Security Limit Control functionality.

MAC-based Auth.:

Unlike port-based 802.1X, MAC-based authentication is not a standard, but merely a best-practices method adopted by the industry. In MAC-based authentication, users are called clients, and the switch acts as the supplicant on behalf of clients. The initial frame (any kind of frame) sent by a client is snooped by the switch, which in turn uses the client's MAC address as both username and password in the subsequent EAP exchange with the RADIUS server. The 6-byte MAC address is converted to a string on the following form "xx-xx-xx-xx-xx-xx", that is, a dash (-) is used as separator between the lower-cased hexadecimal digits. The switch only supports the MD5-Challenge authentication method, so the RADIUS server must be configured accordingly.

When authentication is complete, the RADIUS server sends a success or failure indication, which in turn causes the switch to open up or block traffic for that particular client, using the Port Security module. Only then will frames from the client be forwarded on the switch. There are no EAPOL frames involved in this authentication, and therefore, MAC-based Authentication has nothing to do with the 802.1X standard.

The advantage of MAC-based authentication over port-based 802.1X is that several clients can be connected to the same port (e.g. through a 3rd party switch or a hub) and still require individual authentication, and that the clients don't need special supplicant software to authenticate. The advantage of MAC-based authentication over 802.1X-based authentication is that the clients don't need special supplicant software to authenticate. The disadvantage is that MAC addresses can be spoofed by malicious users - equipment whose MAC address is a valid RADIUS user can be used by anyone. Also, only the MD5-Challenge method is supported. The maximum number of clients that can be attached to a port can be limited using the Port Security Limit Control functionality.

RADIUS-Assigned QoS Enabled:

When RADIUS-Assigned QoS is both globally enabled and enabled (checked) on a given port, the switch reacts to QoS Class information carried in the RADIUS Access-Accept packet transmitted by the RADIUS server when a supplicant is successfully authenticated. If present and valid, traffic received on the supplicant's port will be classified to the given QoS Class. If (re-)authentication fails or the RADIUS Access-Accept packet no longer carries a QoS Class or it's invalid, or the supplicant is otherwise no longer present on the port, the port's QoS Class is immediately reverted to the original QoS Class (which may be changed by the administrator in the meanwhile without affecting the RADIUS-assigned).

This option is only available for single-client modes, i.e.

- Port-based 802.1X
- Single 802.1X

RADIUS attributes used in identifying a QoS Class:

Refer to the written documentation for a description of the RADIUS attributes needed in order to successfully identify a QoS Class. The User-Priority-Table attribute defined in RFC4675 forms the basis for identifying the QoS Class in an Access-Accept packet.

Only the first occurrence of the attribute in the packet will be considered, and to be valid, it must follow this rule:

- All 8 octets in the attribute's value must be identical and consist of ASCII characters in the range '0' - '3', which translates into the desired QoS Class in the range [0; 3].

RADIUS-Assigned VLAN Enabled:

When RADIUS-Assigned VLAN is both globally enabled and enabled (checked) for a given port, the switch reacts to VLAN ID information carried in the RADIUS Access-Accept packet transmitted by the RADIUS server when a supplicant is successfully authenticated. If present and valid, the port's Port VLAN ID will be changed to this VLAN ID, the port will be set to be a member of that VLAN ID, and the port will be forced into VLAN unaware mode. Once assigned, all traffic arriving on the port will be classified and switched on the RADIUS-assigned VLAN ID.

If (re-)authentication fails or the RADIUS Access-Accept packet no longer carries a VLAN ID or it's invalid, or the supplicant is otherwise no longer present on the port, the port's VLAN ID is immediately reverted to the original VLAN ID (which may be changed by the administrator in the meanwhile without affecting the RADIUS-assigned).

This option is only available for single-client modes, i.e.

- Port-based 802.1X
- Single 802.1X

For trouble-shooting VLAN assignments, use the "Monitor VLANs VLAN Membership and VLAN Port" pages. These pages show which modules have (temporarily) overridden the current Port VLAN configuration.

RADIUS attributes used in identifying a VLAN ID:

RFC2868 and RFC3580 form the basis for the attributes used in identifying a VLAN ID in an Access-Accept packet. The following criteria are used:

- The Tunnel-Medium-Type, Tunnel-Type, and Tunnel-Private-Group-ID attributes must all be present at least once in the Access-Accept packet.
- The switch looks for the first set of these attributes that have the same Tag value and fulfill the following requirements (if Tag == 0 is used, the Tunnel-Private-Group-ID does not need to include a Tag):
 - Value of Tunnel-Medium-Type must be set to "IEEE-802" (ordinal 6).
 - Value of Tunnel-Type must be set to "VLAN" (ordinal 13).
 - Value of Tunnel-Private-Group-ID must be a string of ASCII chars in the range '0' - '9', which is interpreted as a decimal string representing the VLAN ID. Leading '0's are discarded. The final value must be in the range [1; 4095].

Guest VLAN Enabled:

When Guest VLAN is both globally enabled and enabled (checked) for a given port, the switch considers moving the port into the Guest VLAN according to the rules outlined below.

This option is only available for EAPOL-based modes, i.e.:

- Port-based 802.1X
- Single 802.1X
- Multi 802.1X

For trouble-shooting VLAN assignments, use the "Monitor VLANs VLAN Membership and VLAN Port" pages. These pages show which modules have (temporarily) overridden the current Port VLAN configuration.

Guest VLAN Operation:

When a Guest VLAN enabled port's link comes up, the switch starts transmitting EAPOL Request Identity frames. If the number of transmissions of such frames exceeds Max. Reauth. Count and no EAPOL frames have been received in the meanwhile, the switch considers entering the Guest VLAN. The interval between transmission of EAPOL Request Identity frames is configured with EAPOL Timeout. If Allow Guest VLAN if EAPOL Seen is enabled, the port will now be placed in the Guest VLAN. If disabled, the switch will first check its history to see if an EAPOL frame has previously been received on the port (this history is cleared if the port link goes down or the port's Admin State is changed), and if not, the port will be placed in the Guest VLAN. Otherwise it will not move to the Guest VLAN, but continue transmitting EAPOL Request Identity frames at the rate given by EAPOL Timeout.

Once in the Guest VLAN, the port is considered authenticated, and all attached clients on the port are allowed access on this VLAN. The switch will not transmit an EAPOL Success frame when entering the Guest VLAN.

While in the Guest VLAN, the switch monitors the link for EAPOL frames, and if one such frame is received, the switch immediately takes the port out of the Guest VLAN and starts authenticating the supplicant according to the port mode. If an EAPOL frame is received, the port will never be able to go back into the Guest VLAN if the "Allow Guest VLAN if EAPOL Seen" is disabled.

Port State:

The current state of the port. It can undertake one of the following values:

Globally Disabled: NAS is globally disabled.

Link Down: NAS is globally enabled, but there is no link on the port.

Authorized: The port is in Force Authorized or a single-supplicant mode and the supplicant is authorized.

Unauthorized: The port is in Force Unauthorized or a single-supplicant mode and the supplicant is not successfully authorized by the RADIUS server.

X Auth/Y Unauth: The port is in a multi-supplicant mode. Currently X clients are authorized and Y are unauthorized.

Restart:

Two buttons are available for each row. The buttons are only enabled when authentication is globally enabled and the port's Admin State is in an EAPOL-based or MAC-based mode.

Clicking these buttons will not cause settings changed on the page to take effect.

Reauthenticate: Schedules a reauthentication whenever the quiet-period of the port runs out (EAPOL-based authentication). For MAC-based authentication, reauthentication will be attempted immediately.

The button only has effect for successfully authenticated clients on the port and will not cause the clients to get temporarily unauthorized.

Reinitialize: Forces a reinitialization of the clients on the port and thereby a reauthentication immediately. The clients will transfer to the unauthorized state while the reauthentication is in progress.

Buttons:

Save – Click to save changes.

Reset – Click to undo any changes made locally and revert to previously saved values.

Refresh:

Refresh the NAS Configuration manually.

5.5.2 Switch Status

The section describes how to show the each port NAS status information of the switch. The status includes Admin State, Port State, Last Source, Last ID, QoS Class, and Port VLAN ID.

To show the NAS Switch Status in the web interface:

1. Go to NAS, Switch Port Status
2. Check "Auto-refresh"

Figure 4-5.2: The Network Access Server Switch Status

Network Access Server Switch Status						
Port	Admin State	Port State	Last Source	Last ID	QoS Class	Port VLAN ID
1	Force Authorized	Globally Disabled				
2	Force Authorized	Globally Disabled				
3	Force Authorized	Globally Disabled				
4	Force Authorized	Globally Disabled				

Parameter description:

Port:

The switch port number. Click to navigate to detailed NAS statistics for this port.

Admin State:

The port's current administrative state. Refer to NAS Admin State for a description of possible values.

Port State:

The current state of the port. Refer to NAS Port State for a description of the individual states.

Last Source:

The source MAC address carried in the most recently received EAPOL frame for EAPOL-based authentication, and the most recently received frame from a new client for MAC-based authentication.

Last ID:

The user name (supplicant identity) carried in the most recently received Response Identity EAPOL frame for EAPOL-based authentication, and the source MAC address from the most recently received frame from a new client for MAC-based authentication.

QoS Class:

QoS Class assigned to the port by the RADIUS server if enabled.

Port VLAN ID:

The VLAN ID that NAS has put the port in. The field is blank, if the Port VLAN ID is not overridden by NAS.

If the VLAN ID is assigned by the RADIUS server, "(RADIUS-assigned)" is appended to the VLAN ID. Read more about RADIUS-assigned VLANs here.

If the port is moved to the Guest VLAN, "(Guest)" is appended to the VLAN ID. Read more about Guest VLANs here.

Auto-refresh:

Activate the auto-refresh to refresh the information automatically.

Refresh:

Refresh the NAS Switch Status manually.

5.5.3 Port Status

The section describes how to provide detailed NAS statistics for a specific switch port running EAPOL-based IEEE 802.1X authentication.

To configure a NAS Port Status in the web interface:

1. Specify Port to check.
2. Checked "Auto-refresh".

Figure 4-5.3: The NAS Statistics

NAS Statistics Port 1 Port 1 Auto-refresh

Port State

Admin State	Force Authorized
Port State	Authorized

Port Counters

Receive EAPOL Counters		Transmit EAPOL Counters	
Total	0	Total	1
Response ID	0	Request ID	0
Responses	0	Requests	0
Start	0		
Logoff	0		
Invalid Type	0		
Invalid Length	0		

Parameter description:

Port State

Admin State:

The port's current administrative state. Refer to NAS Admin State for a description of possible values.

Port State:

The current state of the port. Refer to NAS Port State for a description of the individual states.

QoS Class:

The QoS class assigned by the RADIUS server. The field is blank if no QoS class is assigned.

Port VLAN ID:

The VLAN ID that NAS has put the port in. The field is blank, if the Port VLAN ID is not overridden by NAS.

If the VLAN ID is assigned by the RADIUS server, "(RADIUS-assigned)" is appended to the VLAN ID. Read more about RADIUS-assigned VLANs here.

If the port is moved to the Guest VLAN, "(Guest)" is appended to the VLAN ID. Read more about Guest VLANs here.

Port Counters

EAPOL Counters:

These supplicant frame counters are available for the following administrative states:

- Force Authorized
- Force Unauthorized
- Port-based 802.1X
- Single 802.1X
- Multi 802.1X

Backend Server Counters:

These backend (RADIUS) frame counters are available for the following administrative states:

- Port-based 802.1X
- Single 802.1X
- Multi 802.1X
- MAC-based Auth.

Last Supplicant/Client Info:

Information about the last supplicant/client that attempted to authenticate. This information is available for the following administrative states:

- Port-based 802.1X
- Single 802.1X
- Multi 802.1X
- MAC-based Auth.

Selected Counters

Selected Counters:

The Selected Counters table is visible when the port is in one of the following administrative states:

- Multi 802.1X
- MAC-based Auth.

The table is identical to and is placed next to the Port Counters table, and will be empty if no MAC address is currently selected. To populate the table, select one of the attached MAC Addresses from the table below.

Attached MAC Addresses

Identity:

Shows the identity of the supplicant, as received in the Response Identity EAPOL frame. Clicking the link causes the supplicant's EAPOL and Backend Server counters to be shown in the Selected Counters table. If no supplicants are attached, it shows No supplicants attached.

This column is not available for MAC-based Auth.

MAC Address:

For Multi 802.1X, this column holds the MAC address of the attached supplicant. For MAC-based Auth., this column holds the MAC address of the attached client.

Clicking the link causes the client's Backend Server counters to be shown in the Selected Counters table. If no clients are attached, it shows No clients attached.

VLAN ID

This column holds the VLAN ID that the corresponding client is currently secured through the Port Security module.

State:

The client can either be authenticated or unauthenticated. In the authenticated state, it is allowed to forward frames on the port, and in the unauthenticated state, it is blocked. As long as the backend server hasn't successfully authenticated the client, it is unauthenticated. If an authentication fails for one or the other reason, the client will remain in the unauthenticated state for Hold Time seconds.

Last Authentication:

Shows the date and time of the last authentication of the client (successful as well as unsuccessful).

Auto-refresh:

Activate the auto-refresh to refresh the information automatically.

Refresh:

Refresh the NAS Statistics manually.

Clear:

Clear all entries.

5.6 AAA

This section shows you to use an AAA (Authentication, Authorization, Accounting) server to provide access control to your network. The AAA server can be a TACACS+ or RADIUS server to create and manage objects that contain settings for using AAA servers.

5.6.1 Configuration

This section describes how to configure AAA for TACACS+ or RADIUS server.

To configure AAA in the web interface:

1. Set Timeout (Default is 15 seconds).
2. Set Dead Time (Default is 300 seconds).

To configure a TACACS+ Authorization and Accounting Configuration of AAA in the web interface:

1. Select "Enabled" in the Authorization.
2. Select "Enabled" in the Failback to Local Authorization.

3. Select "Enabled" in the Account.

To configure a RADIUS Authentication Server Configuration of AAA in the web interface:

1. Check "Enabled".
2. Specify IP address or Hostname for Radius Server.
3. Specify Authentication Port for Radius Server (Default is 1812).
4. Specify the Secret with Radius Server.

To configure a RADIUS Accounting Server Configuration of AAA in the web interface:

1. Check "Enabled".
2. Specify IP address or Hostname for Radius Server.
3. Specify Accounting Port for Radius Server (Default is 1813).
4. Specify the Secret with Radius Server.

To configure a TACACS+ Authentication Server Configuration of AAA in the web interface:

1. Check "Enabled".
2. Specify IP address or Hostname for TACACS+ Server.
3. Specify Authentication Port for TACACS+ Server (Default is 49).
4. Specify the Secret with TACACS+ Server.

Figure 4-5.3.1: The Common Server Configuration

Authentication Server Configuration

Common Server Configuration

Timeout	15	seconds
Dead Time	300	seconds

Figure 4-5.3.2: The TACACS+ Accounting Configuration

TACACS+ Authorization and Accounting Configuration

Authorization	Disabled
Fallback to Local Authorization	Disabled
Accounting	Disabled

Figure 4-5.3.3: The RADIUS Configuration

RADIUS Authentication Server Configuration

#	Enabled	IP Address/Hostname	Port	Secret
1	<input type="checkbox"/>		1812	
2	<input type="checkbox"/>		1812	
3	<input type="checkbox"/>		1812	
4	<input type="checkbox"/>		1812	
5	<input type="checkbox"/>		1812	

Figure 4-5.3.4: The RADIUS Accounting Configuration

RADIUS Accounting Server Configuration				
#	Enabled	IP Address/Hostname	Port	Secret
1	<input type="checkbox"/>		1813	
2	<input type="checkbox"/>		1813	
3	<input type="checkbox"/>		1813	
4	<input type="checkbox"/>		1813	
5	<input type="checkbox"/>		1813	

Figure 4-5.3.4: The TACACS+ Authentication Configuration

TACACS+ Authentication Server Configuration				
#	Enabled	IP Address/Hostname	Port	Secret
1	<input type="checkbox"/>		49	
2	<input type="checkbox"/>		49	
3	<input type="checkbox"/>		49	
4	<input type="checkbox"/>		49	
5	<input type="checkbox"/>		49	

Save Reset

Parameter description:

Timeout:

The Timeout, which can be set to a number between 3 and 3600 seconds, is the maximum time to wait for a reply from a server.

If the server does not reply within this timeframe, we will consider it to be dead and continue with the next enabled server (if any).

RADIUS servers are using the UDP protocol, which is unreliable by design. In order to cope with lost frames, the timeout interval is divided into 3 subintervals of equal length. If a reply is not received within the subinterval, the request is transmitted again. This algorithm causes the RADIUS server to be queried up to 3 times before it is considered to be dead.

Dead Time:

The Dead Time, which can be set to a number between 0 and 3600 seconds, is the period during which the switch will not send new requests to a server that has failed to respond to a previous request. This will stop the switch from continually trying to contact a server that it has already determined as dead.

Setting the Dead Time to a value greater than 0 (zero) will enable this feature, but only if more than one server has been configured.

RADIUS Authentication Server Configuration

The table has one row for each RADIUS Authentication Server and a number of columns, which are:

#:

The RADIUS Authentication Server number for which the configuration below applies.

Enabled:

Enable the RADIUS Authentication Server by checking this box.

IP Address/Hostname:

The IP address or hostname of the RADIUS Authentication Server. IP address is expressed in dotted decimal notation.

Port:

The UDP port to use on the RADIUS Authentication Server. If the port is set to 0 (zero), the default port (1812) is used on the RADIUS Authentication Server.

Secret:

The secret - up to 29 characters long - shared between the RADIUS Authentication Server and the switch.

RADIUS Accounting Server Configuration

The table has one row for each RADIUS Accounting Server and a number of columns, which are:

#:

The RADIUS Accounting Server number for which the configuration below applies.

Enabled:

Enable the RADIUS Accounting Server by checking this box.

IP Address/Hostname:

The IP address or hostname of the RADIUS Accounting Server. IP address is expressed in dotted decimal notation.

Port:

The UDP port to use on the RADIUS Accounting Server. If the port is set to 0 (zero), the default port (1813) is used on the RADIUS Accounting Server.

Secret:

The secret - up to 29 characters long - shared between the RADIUS Accounting Server and the switch.

TACACS+ Authentication Server Configuration

The table has one row for each TACACS+ Authentication Server and a number of columns, which are:

#:

The TACACS+ Authentication Server number for which the configuration below applies.

Enabled:

Enable the TACACS+ Authentication Server by checking this box.

IP Address/Hostname:

The IP address or hostname of the TACACS+ Authentication Server. IP address is expressed in dotted decimal notation.

Port:

The TCP port to use on the TACACS+ Authentication Server. If the port is set to 0 (zero), the default port (49) is used on the TACACS+ Authentication Server.

Secret:

The secret - up to 29 characters long - shared between the TACACS+ Authentication Server and the switch.

Buttons:

Save – Click to save changes.

Reset – Click to undo any changes made locally and revert to previously saved values.

5.6.2 Radius Overview

This section provides an overview of the RADIUS Authentication and Accounting servers status to ensure the function is working.

To show the RADIUS Overview in the web interface:

1. Check "Auto-refresh".

Figure 4-6.2: The RADIUS Authentication Server Status Overview

RADIUS Authentication Server Status Overview		
Auto-refresh <input type="checkbox"/> <input type="button" value="Refresh"/>		
#	IP Address	Status
1	0.0.0.0:1812	Disabled
2	0.0.0.0:1812	Disabled
3	0.0.0.0:1812	Disabled
4	0.0.0.0:1812	Disabled
5	0.0.0.0:1812	Disabled

RADIUS Accounting Server Status Overview		
#	IP Address	Status
1	0.0.0.0:1813	Disabled
2	0.0.0.0:1813	Disabled
3	0.0.0.0:1813	Disabled
4	0.0.0.0:1813	Disabled
5	0.0.0.0:1813	Disabled

Parameter description:

#:

The RADIUS server number. Click to navigate to detailed statistics for this server.

IP Address:

The IP address and UDP port number (in <IP Address>:<UDP Port> notation) of this server.

State:

The current state of the server. This field takes one of the following values:

Disabled: The server is disabled.

Not Ready: The server is enabled, but IP communication is not yet up and running.

Ready: The server is enabled, IP communication is up and running, and the RADIUS module is ready to accept access attempts.

Dead (X seconds left): Access attempts were made to this server, but it did not reply within the configured timeout. The server has temporarily been disabled, but will get re-enabled when the dead-time expires. The number of seconds left before this occurs is displayed in parentheses. This state is only reachable when more than one server is enabled.

RADIUS Accounting Servers

#:

The RADIUS server number. Click to navigate to detailed statistics for this server.

IP Address:

The IP address and UDP port number (in <IP Address>:<UDP Port> notation) of this server.

State:

The current state of the server. This field takes one of the following values:

Disabled: The server is disabled.

Not Ready: The server is enabled, but IP communication is not yet up and running.

Ready: The server is enabled, IP communication is up and running, and the RADIUS module is ready to accept accounting attempts.

Dead (X seconds left): Accounting attempts were made to this server, but it did not reply within the configured timeout. The server has temporarily been disabled, but will get re-enabled when the dead-time expires. The number of seconds left before this occurs is displayed in parentheses. This state is only reachable when more than one server is enabled.

Auto-refresh:

Activate the auto-refresh to refresh the information automatically.

Refresh:

Refresh the RADIUS Status manually.

5.6.3 Radius Details

This section provides detailed statistics of the RADIUS Authentication and Accounting servers. The statistics map closely to those specified in RFC4668 - RADIUS Authentication Client MIB.

To configure RADIUS Details in the web interface:

1. Specify Port which want to check.
2. Checked "Auto-refresh".

Figure 4-6.3: The RADIUS Authentication Statistics Server

RADIUS Authentication Statistics for Server #1 (0.0.0.0:1812)

Server #1 Auto-refresh

Receive Packets		Transmit Packets	
Access Accepts	0	Access Requests	0
Access Rejects	0	Access Retransmissions	0
Access Challenges	0	Pending Requests	0
Malformed Access Responses	0	Timeouts	0
Bad Authenticators	0		
Unknown Types	0		
Packets Dropped	0		
Other Info			
State			Disabled
Round-Trip Time			0 ms

RADIUS Accounting Statistics for Server #1 (0.0.0.0:1813)

Receive Packets		Transmit Packets	
Responses	0	Requests	0
Malformed Responses	0	Retransmissions	0
Bad Authenticators	0	Pending Requests	0
Unknown Types	0	Timeouts	0
Packets Dropped	0		
Other Info			
State			Disabled
Round-Trip Time			0 ms

Parameter description:

Auto-refresh:

Activate the auto-refresh to refresh the information automatically.

Refresh:

Refresh the RADIUS Statistics information manually.

Clear:

Clear all entries.

5.7 Port Security

This section shows how to configure the Port Security settings of the Switch. You can use the Port Security feature to restrict input to an interface by limiting and identifying MAC addresses.

5.7.1 Limit Control

This section shows how to configure the Port Security settings of the Switch. You can use the Port Security feature to restrict input to an interface by limiting and identifying MAC addresses.

Web Interface

To configure Limit Control in the web interface:

1. Select "Enabled" in the Mode of System Configuration.
2. Check Aging Enabled.
3. Set Aging Period (Default is 3600 seconds).

To configure a Port Configuration of Limit Control in the web interface:

1. Select "Enabled" in the Mode of Port Configuration.
2. Specify the limit of MAC addresses.
3. Set Action (Trap, Shutdown, Trap & Shutdown)
4. Click Save.

Figure 4-7.1: The Port Security Limit Control Configuration

Port	Mode	Limit	Action	State	Re-open
*	<>	4	<>		
1	Disabled	4	None	Disabled	Reopen
2	Disabled	4	None	Disabled	Reopen
3	Disabled	4	None	Disabled	Reopen
50	Disabled	4	None	Disabled	Reopen
51	Disabled	4	None	Disabled	Reopen
52	Disabled	4	None	Disabled	Reopen

Parameter description:

System Configuration

Mode:

Indicates if Limit Control is globally enabled or disabled on the switch. If globally disabled, other modules may still use the underlying functionality, but limit checks and corresponding actions are disabled.

Aging Enabled:

If checked, secured MAC addresses are subject to aging as discussed under Aging Period.

Aging Period:

If Aging Enabled is checked, then the aging period is controlled with this input. If other modules are using the underlying port security for securing MAC addresses, they may have other requirements to the aging period. The underlying port security will use the shorter requested aging period of all modules that use the functionality.

The Aging Period can be set to a number between 10 and 10,000,000 seconds.

To understand why aging may be desired, consider the following scenario: Suppose an end-host is connected to a 3rd party switch or hub, which in turn is connected to a port on this switch on which Limit Control is enabled. The end-host will be allowed to forward if the limit is not exceeded. Now suppose that the end-host logs off or powers down. If it

wasn't for aging, the end-host would still take up resources on this switch and will be allowed to forward. To overcome this situation, enable aging. With aging enabled, a timer is started once the end-host gets secured. When the timer expires, the switch starts looking for frames from the end-host, and if such frames are not seen within the next Aging Period, the end-host is assumed to be disconnected, and the corresponding resources are freed on the switch.

Port Configuration

The table has one row for each port on the selected switch and a number of columns, which are:

Port:

The port number to which the configuration below applies.

Mode:

Controls whether Limit Control is enabled on this port. Both this and the Global Mode must be set to Enabled for Limit Control to be in effect. Notice that other modules may still use the underlying port security features without enabling Limit Control on a given port.

Limit:

The maximum number of MAC addresses that can be secured on this port. This number cannot exceed 1024. If the limit is exceeded, the corresponding action is taken.

The switch is "born" with a total number of MAC addresses from which all ports draw whenever a new MAC address is seen on a Port Security-enabled port. Since all ports draw from the same pool, it may happen that a configured maximum cannot be granted, if the remaining ports have already used all available MAC addresses.

Action:

If Limit is reached, the switch can take one of the following actions:

None: Do not allow more than Limit MAC addresses on the port, but take no further action.

Trap: If Limit + 1 MAC addresses is seen on the port, send an SNMP trap. If Aging is disabled, only one SNMP trap will be sent, but with Aging enabled, new SNMP traps will be sent every time the limit gets exceeded.

Shutdown: If Limit + 1 MAC addresses is seen on the port, shut down the port. This implies that all secured MAC addresses will be removed from the port, and no new address will be learned. Even if the link is physically disconnected and reconnected on the port (by disconnecting the cable), the port will remain shut down. There are three ways to re-open the port:

Boot the switch,

Disable and re-enable Limit Control on the port or the switch,

Click the Reopen button.

Trap & Shutdown: If Limit + 1 MAC addresses is seen on the port, both the "Trap" and the "Shutdown" actions described above will be taken.

State:

This column shows the current state of the port as seen from the Limit Control's point of view. The state takes one of four values:

Disabled: Limit Control is either globally disabled or disabled on the port.

Ready: The limit is not yet reached. This can be shown for all actions.

Limit Reached: Indicates that the limit is reached on this port. This state can only be shown if Action is set to None or Trap.

Shutdown: Indicates that the port is shut down by the Limit Control module. This state can only be shown if Action is set to Shutdown or Trap & Shutdown.

Re-open Button:

If a port is shutdown by this module, you may reopen it by clicking this button, which will only be enabled if this is the case. For other methods, refer to Shutdown in the Action section.

 Clicking the reopen button causes the page to be refreshed, so non-committed changes will be lost

Upper right icon (Refresh):

Refresh the Port Security information manually.

Buttons:

Save – Click to save changes.

Reset – Click to undo any changes made locally and revert to previously saved values.

5.7.2 Switch Status

This section shows the Port Security status. Port Security is a module with no direct configuration. Configuration comes indirectly from other modules - the user modules. When a user module has enabled port security on a port, the port is set-up for software-based learning. In this mode, frames from unknown MAC addresses are passed on to the port security module, which in turn asks all user modules whether to allow this new MAC address to forward or block it. For a MAC address to be set in the forwarding state, all enabled user modules must unanimously agree on allowing the MAC address to forward. If only one chooses to block it, it will be blocked until that user module decides otherwise. The status page is divided into two sections - one with a legend of user modules and one with the actual port status.

To configure Port Security Switch Status in the web interface:

1. Check "Auto-refresh"

Figure 4-7.2: The Port Security Switch Status



Port Security Switch Status		Auto-refresh	Refresh	
User Module Legend				
User Module Name	Abbr			
Limit Control	L			
802.1X	8			
DHCP Snooping	D			
Voice VLAN	V			
Port Status				
Port	Users	State	MAC Count	
			Current	Limit
1	----	Disabled	-	-
2	----	Disabled	-	-
3	----	Disabled	-	-
4	----	Disabled	-	-
5	----	Disabled	-	-
6	----	Disabled	-	-

Parameter description:

User Module Legend:

The legend shows all user modules that may request Port Security services.

User Module Name:

The full name of a module that may request Port Security services.

Abbr:

A one-letter abbreviation of the user module. This is used in the Users column in the port status table.

Port Status:

The table has one row for each port on the selected switch and a number of columns, which are:

Port:

The port number for which the status applies. Click the port number to see the status for this particular port.

Users:

Each of the user modules has a column that shows whether that module has enabled Port Security or not. A '-' means that the corresponding user module is not enabled, whereas a letter indicates that the user module abbreviated by that letter (see Abbr) has enabled port security.

State:

Shows the current state of the port. It can take one of four values:

Disabled: No user modules are currently using the Port Security service.

Ready: The Port Security service is in use by at least one user module, and is awaiting frames from unknown MAC addresses to arrive.

Limit Reached: The Port Security service is enabled by at least the Limit Control user module, and that module has indicated that the limit is reached and no more MAC addresses should be taken in.

Shutdown: The Port Security service is enabled by at least the Limit Control user module, and that module has indicated that the limit is exceeded. No MAC addresses can be learned on the port until it is administratively re-opened on the Limit Control configuration Web-page.

MAC Count (Current, Limit):

The two columns indicate the number of currently learned MAC addresses (forwarding as well as blocked) and the maximum number of MAC addresses that can be learned on the port, respectively.

If no user modules are enabled on the port, the Current column will show a dash (-).

If the Limit Control user module is not enabled on the port, the Limit column will show a dash (-).

Indicates the number of currently learned MAC addresses (forwarding as well as blocked) on the port. If no user modules are enabled on the port, a dash (-) will be shown.

Auto-refresh:

Activate the auto-refresh to refresh the information automatically.

Refresh

Refresh the Port Security Switch Status information manually.

5.7.3 Port Status

This section shows the MAC addresses secured by the Port Security module. Port Security is a module with no direct configuration. Configuration comes indirectly from other modules - the user modules. When a user module has enabled port security on a port, the port is set-up for software-based learning. In this mode, frames from unknown MAC addresses are passed on to the port security module, which in turn asks all user modules whether to allow this new MAC address to forward or block it. For a MAC address to be set in the forwarding state, all enabled user modules must unanimously agree on allowing the MAC address to forward. If only one chooses to block it, it will be blocked until that user module decides otherwise.

Web Interface

To show the Port Security Switch Status in the web interface:

1. Specify the Port you want to monitor.
2. Check "Auto-refresh".

Figure 4-7.3: The Port Security Port Status

Port Security Port Status Port 1				
MAC Address	VLAN ID	State	Time of Addition	Age/Hold
No MAC addresses attached				

Parameter description:

MAC Address & VLAN ID:

The MAC address and VLAN ID that is seen on this port. If no MAC addresses are learned, a single row stating "No MAC addresses attached" is displayed.

State:

Indicates whether the corresponding MAC address is blocked or forwarding. In the blocked state, it will not be allowed to transmit or receive traffic.

Time of Addition:

Shows the date and time when this MAC address was first seen on the port.

Age/Hold:

If at least one user module has decided to block this MAC address, it will stay in the blocked state until the hold time (measured in seconds) expires. If all user modules have decided to allow this MAC address to forward, and aging is enabled, the Port Security module will periodically check that this MAC address still forwards traffic. If the age period (measured in seconds) expires and no frames have been seen, the MAC address will be removed from the MAC table. Otherwise a new age period will begin.

If aging is disabled or a user module has decided to hold the MAC address indefinitely, a dash (-) will be shown.

Auto-refresh:

Activate the auto-refresh to refresh the information automatically.

Refresh

Refresh the Port Security Port Status information manually.

5.8 Access Management

This section explains how to configure access management of the switch including HTTP/HTTPS, SNMP, and TELNET/SSH. You can manage the Switch over an Ethernet LAN, or over the Internet.

5.8.1 Configuration

This section shows you how to configure access management table of the Switch. The maximum entry number is 16. If the application's type match any one of the access management entries, it will allow access to the switch.

Web Interface

To configure Access Management in the web interface:

1. Select "Enabled" in the Mode of Access Management Configuration.
2. Click "Add new entry".
3. Specify the Start IP Address, End IP Address.
4. Checked Access Management method (HTTP/HTTPS, SNMP, and TELNET/SSH) in the entry.
5. Click Save.

Figure 4-8.1: The Access Management Configuration

Access Management Configuration

Mode: Disabled

Delete Start IP Address End IP Address HTTP/HTTPS SNMP TELNET/SSH

Add new entry

Save Reset

Access Management Configuration

Mode: Disabled

Delete	Start IP Address	End IP Address	HTTP/HTTPS	SNMP	TELNET/SSH
Delete	0.0.0.0	0.0.0.0	<input type="checkbox"/>	<input type="checkbox"/>	<input type="checkbox"/>

Add new entry

Save Reset

Parameter description:

Mode:

Indicates the access management mode operation. Possible modes are:

Enabled: Enable access management mode operation.

Disabled: Disable access management mode operation.

Delete:

Delete the entry. It will be deleted during the next save.

Start IP address:

Indicates the start IP address for the access management entry.

End IP address:

Indicates the end IP address for the access management entry.

HTTP/HTTPS:

Indicates that the host can access the switch from HTTP/HTTPS interface if the host IP address matches the IP address range provided in the entry.

SNMP:

Indicates that the host can access the switch from SNMP interface if the host IP address matches the IP address range provided in the entry.

TELNET/SSH:

Indicates that the host can access the switch from TELNET/SSH interface if the host IP address matches the IP address range provided in the entry.

Buttons:

Save – Click to save changes.

Reset – Click to undo any changes made locally and revert to previously saved values.

5.8.2 Statistics

This section shows you detailed statistics of the Access Management including HTTP, HTTPS, SSH, TELNET, and SSH.

Web Interface

To configure Access Management Statistics in the web interface:

1. Check "Auto-refresh".

Figure 4-8.2: The Access Management Statistics

Interface	Received Packets	Allowed Packets	Discarded Packets
HTTP	0	0	0
HTTPS	0	0	0
SNMP	0	0	0
TELNET	0	0	0
SSH	0	0	0

Parameter description:

Interface:

The interface type through which the remote host can access the switch.

Received Packets:

Number of received packets from the interface when access management mode is enabled.

Allowed Packets:

Number of allowed packets from the interface when access management mode is enabled

Discarded Packets.:

Number of discarded packets from the interface when access management mode is enabled.

Auto-refresh:

Activate the auto-refresh to refresh the information automatically.

Refresh

Refresh the Access Management Statistics information manually.

Clear

Clear the statistics.

5.9 SSH

This section shows you to use SSH (Secure Shell) to securely access the Switch. SSH is a secure communication protocol that combines authentication and data encryption to provide secure encrypted communication.

Web Interface

To configure SSH in the web interface:

1. Select "Enabled" in the Mode of SSH Configuration.
2. Click "Save".

Figure 4-9.1: The SSH Configuration

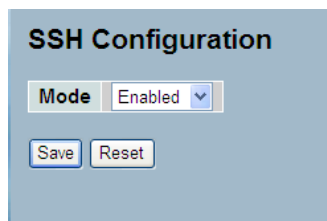

SSH Configuration

Mode: Enabled

Save Reset

Parameter description:

Mode:

Indicates the SSH mode operation. Possible modes are:

Enabled: Enable SSH mode operation.

Disabled: Disable SSH mode operation.

Buttons:

Save – Click to save changes.

Reset – Click to undo any changes made locally and revert to previously saved values.

5.10 HTTPS

This section shows how to use HTTPS to securely access the Switch. HTTPS is a secure communication protocol that combines authentication and data encryption to provide secure encrypted communication via the browser.

Web Interface

To configure a HTTPS in the web interface:

1. Select "Enabled" in the Mode of HTTPS Configuration.
2. Select "Enabled" in the Automatic Redirect of HTTPS Configuration.
3. Click Save.

Figure 4-10.1: The HTTPS Configuration

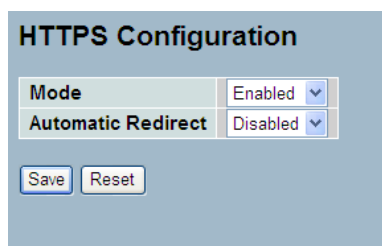

HTTPS Configuration

Mode: Enabled

Automatic Redirect: Disabled

Save Reset

Parameter description:

Mode:

Indicates the HTTPS mode operation. Possible modes are:

Enabled: Enable HTTPS mode operation.

Disabled: Disable HTTPS mode operation.

Automatic Redirect:

Indicates the HTTPS redirect mode operation. Automatically redirect web browser to HTTPS when HTTPS mode is enabled.
Possible modes are:

Enabled: Enable HTTPS redirect mode operation.

Disabled: Disable HTTPS redirect mode operation.

5.11 Auth Method

This page shows how to configure the user authentication method of the switch.

Web Interface

To configure a Authentication Method in the web interface:

1. Specify the Client (console, telnet, ssh, web) which you want to monitor.
2. Specify the Authentication Method (none, local, radius, tacacs+)
3. Check Fallback.
4. Click Save.

Figure 4-11.1: The HTTPS Configuration

Client	Authentication Method	Fallback
console	local	<input type="checkbox"/>
telnet	local	<input type="checkbox"/>
ssh	local	<input type="checkbox"/>
web	local	<input type="checkbox"/>

Save Reset

Parameter description:

Client:

The management client for which the configuration below applies.

Authentication Method:

Authentication Method can be set to one of the following values:

none: authentication is disabled and login is not possible.

local: use the local user database on the switch for authentication.

radius: use a remote RADIUS server for authentication.

tacacs+: use a remote TACACS+ server for authentication.

Fallback:

Enable fallback to local authentication by checking this box.

If none of the configured authentication servers are alive, the local user database is used for authentication.

This is only possible if the Authentication Method is set to a value other than 'none' or 'local'.

Buttons:

Save – Click to save changes.

Reset – Click to undo any changes made locally and revert to previously saved values.

6 Maintenance

This chapter describes all of the switch Maintenance configuration tasks to enhance the performance of local network including Restart Device, Firmware upgrade, Save/Restore, Import/Export, and Diagnostics.

6.1 Restart Device

This section describes how to restart switch for any maintenance needs. Any configuration files or scripts that you saved in the switch should still be available afterwards.

Web Interface

To restart the device:

1. Click Restart Device.
2. Click Yes.

Figure 5-1.1: Restart Device

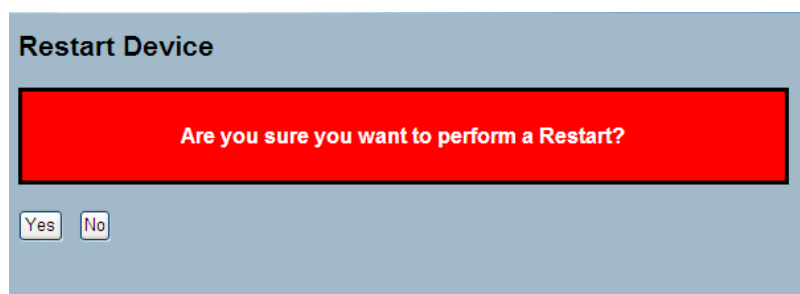

Parameter description:

Restart Device:

You can restart the switch on this page. After restart, the switch will boot normally.

Buttons:

Yes – Click to restart the device.

No- Click to undo any restart action.

6.2 Firmware

This section describes how to upgrade the Firmware. The Switch can be enhanced with more value-added functions by installing firmware upgrades.

6.2.1 Firmware Upgrade

This page facilitates an update of the firmware of the switch.

Web Interface

To upgrade the firmware via the web interface:

1. Click "Browse..." to select the firmware for your device.
2. Click "Upload".

Figure 5-2.1: The Firmware update

Parameter description:

Browse:

Click the "Browse..." button to search the Firmware URL or filename.

Upload:

Click the "Upload" button start the upload of the firmware from the specified location.

! This page facilitates an update of the firmware controlling the switch. Uploading software will update all managed switches according to the software image. After the software image is uploaded, a page announces that the firmware update is initiated. After about a minute, the firmware is updated and all managed switches restart.

! WARNING: While the firmware is being updated, Web access appears to be defunct. The front LED flashes Green/Off with a frequency of 10 Hz while the firmware update is in progress. Do not restart or power off the device at this time or the switch may fail to function afterwards.

6.2.2 Firmware Selection

The switch supports dual images for firmware redundancy purposes. You can select the firmware image for your devices' start firmware or operating firmware. This page provides information about the active and alternate (backup) firmware images in the device, and allows you to revert to the alternate image.

Web Interface

To select the firmware in the web interface:

1. Click "Activate" Alternate Image.
2. Click "Yes" to complete firmware selection.

Figure 5-2.2: The Firmware Selection

Active Image	
Image	managed
Version	GS-2352 (standalone) v1.30
Date	2012-04-26T15:08:42+08:00

Alternate Image	
Image	managed
Version	GS-2352 (standalone) v1.30
Date	2012-04-26T15:08:42+08:00

Activate Alternate Image Cancel

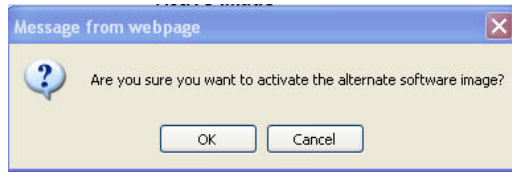

Parameter description:

Activate Alternate Image:

Click to use the alternate image. This button may be disabled depending on system state.

Cancel:

Cancel activating the backup image. Navigates away from this page.

Image:

The flash index name of the firmware image. The name of the primary (preferred) image is image, the alternate image is named image.bk.

Version:

The version of the firmware image.

Date:

The date where the firmware was produced.



In case the active firmware image is the alternate image, only the "Active Image" table is shown. In this case, the Activate Alternate Image button is also disabled.

If the alternate image is active (due to a corruption of the primary image or manually intervention), uploading a new firmware image to the device will automatically use the primary image slot and activate it.

The firmware version and date information may be empty for older firmware releases. This does not constitute an error.

6.3 Save / Restore

This section describes how to save and restore the Switch configuration including reset to Factory Defaults, Save Start, Save Users, Restore Users for any maintenance needs.

6.3.1 Factory Defaults

This section describes how to reset the Switch configuration to Factory Defaults. Any configuration files or scripts will be set to factory default values.

Web Interface

To reset to Factory Defaults in the web interface:

1. Click "Factory Defaults".
2. Click "Yes".

Figure 5-3.1: The Factory Defaults

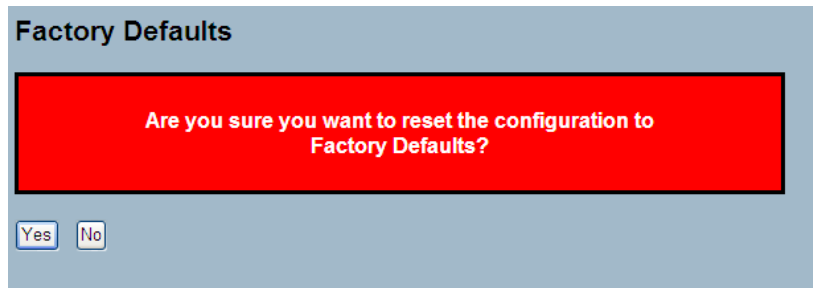

Parameter description:

Buttons:

Yes – Click to reset the configuration to Factory Defaults.

No – Click to return to the Port State page without resetting the configuration.

6.3.2 Save Start

This section describes how to save the Switch Start configuration. Any current configuration files will be saved in XML format.

Web Interface

To save a Start Configuration via the web interface:

1. Click "Save Start".
2. Click "Yes".

Figure 5-3.2: The Save as Start configuration

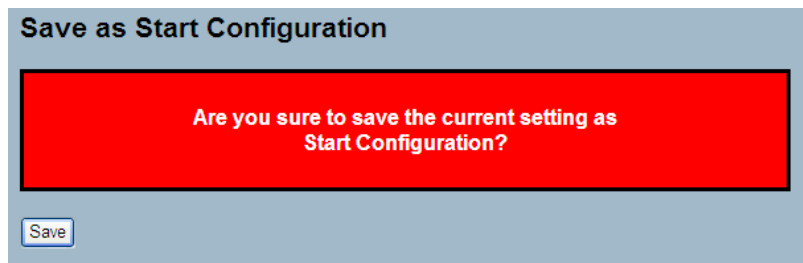

Parameter description:

Buttons:

Save – Click to save current configuration as Start Configuration.

6.3.3 Save User

This section describes how to save users information. Any current configuration file will be saved in XML format.

Web Interface

To save a User configuration in the web interface:

1. Click "Save User".
2. Click "Yes".

Figure 5-3.3: The Save as Backup Configuration

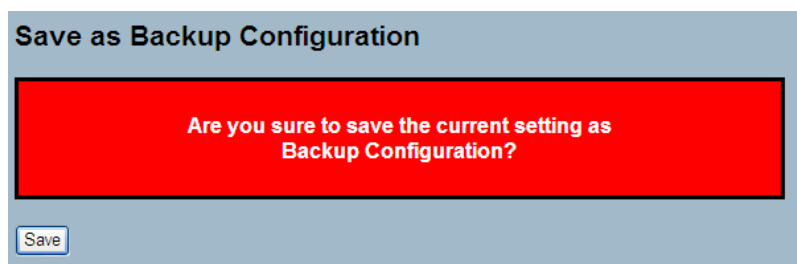

Parameter description:

Buttons:

Save – Click to save current settings as Backup Configuration.

6.3.4 Restore User

This section describes how to restore users information back to the switch. Any current configuration file will be restored via XML.

Web Interface

To restore a User configuration in the web interface:

1. Click "Restore User".
2. Click "Yes".

Figure 5-3.4: Restore the Backup Configuration

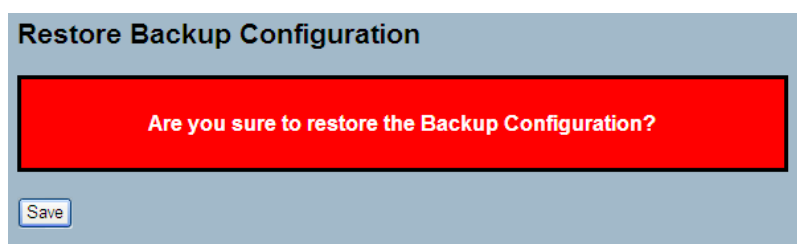

Parameter description:

Buttons:

Save – Click to restore the Backup Configuration to the switch.

6.4 Export / Import

This section describes how to export and import the Switch configuration. Any current configuration file will be exported in XML format.

6.4.1 Export Config

This section describes how to export the Switch Configuration for maintenance needs. Any current configuration file will be exported in XML format.

Web Interface

To export a configuration through the web interface:

1. Click "Save configuration".

2. Save the file to your device.

Figure 5-4.1: Export Configuration

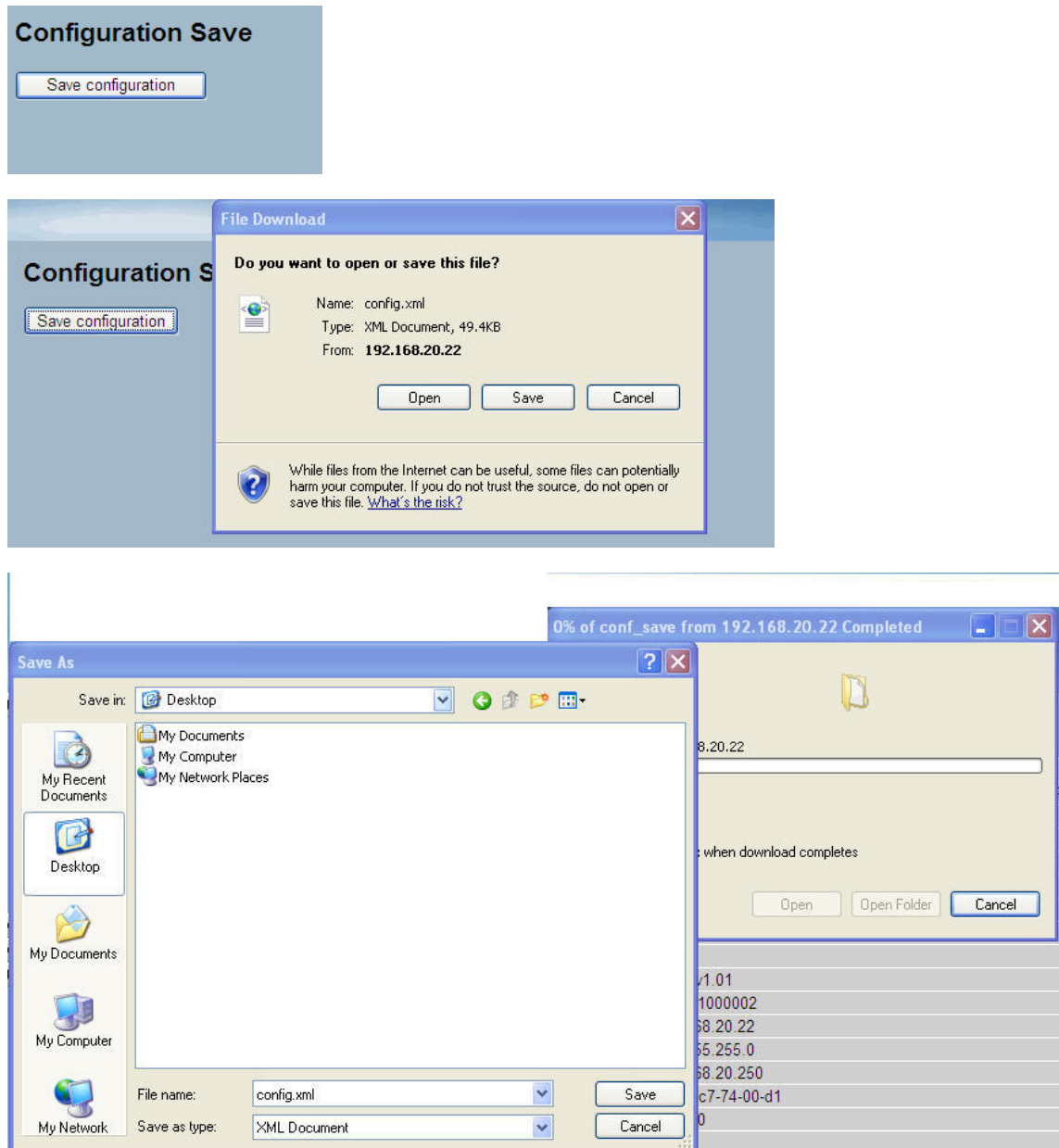

Parameter description:

Save – Click to store the configuration on the PC or server.

6.4.2 Import Config

This section describes how to import the switch configuration for maintenance needs. Any current configuration file will be imported via XML format.

Web Interface

To import a configuration via the web interface:

1. Click "Browse..." to select the config file on your device.

2. Click "Upload".

Figure 5-4.2: Import Config

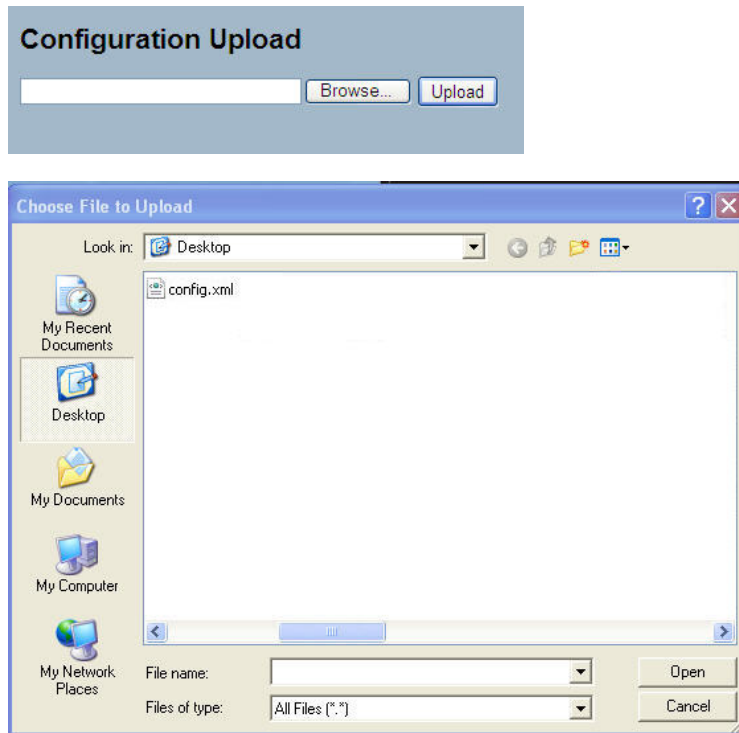

Parameter description:

Browse:

Click to search for the Configuration URL and filename.

Upload:

Click to upload the configuration from the specified location.

6.5 Diagnostics

This section provides a set for basic system diagnosis. It let users know that whether the system is healthy or needs to be fixed. The basic system check includes ICMP Ping, ICMPv6, and VeriPHY Cable Diagnostics.

6.5.1 Ping

This section allows you to issue ICMP PING packets to troubleshoot IPv4 connectivity issues.

Web Interface

To use ICMP PING in the web interface:

1. Specify the IP Address.
2. Specify the Ping Size.
3. Click Start.

Figure 5-5.1: The ICMP Ping

Parameter description:

IP Address:

The IP Address of the device to ping.

Ping Size:

The size of the ICMP Packet being sent.

Start:

Click the "Start" button, the switch will start to ping the device using the set ICMP packet size.

Once you pressed "Start", 5 ICMP packets are transmitted, and the sequence number and roundtrip time are displayed upon reception of a reply. The page refreshes automatically until responses to all packets are received, or until a timeout occurs.

PING server::10.10.132.20

64 bytes from::10.10.132.20: icmp_seq=0, time=0ms

64 bytes from::10.10.132.20: icmp_seq=1, time=0ms

64 bytes from::10.10.132.20: icmp_seq=2, time=0ms

64 bytes from::10.10.132.20: icmp_seq=3, time=0ms

64 bytes from::10.10.132.20: icmp_seq=4, time=0ms

Sent 5 packets, received 5 OK, 0 bad

6.5.2 Ping6

This section allows you to issue ICMPv6 PING packets to troubleshoot IPv6 connectivity issues.

Web Interface

To use ICMPv6 PING in the web interface:

- 1.Specify the IP Address.
- 2.Specify the PING Size.
- 3.Click Start.

Figure 5-5.2: The ICMPv6 Ping

Parameter description:

IP Address:

The destination IPv6 Address

Ping Size:

The payload size of the ICMP packet. Values range from 8 bytes to 1400 bytes.

Start:

Click the "Start" button, the switch will start to ping the device using the set ICMPv6 packet size.

Once you pressed "Start", 5 ICMPv6 packets are transmitted, and the sequence number and roundtrip time are displayed upon reception of a reply. The page refreshes automatically until responses to all packets are received, or until a timeout occurs.

```
PING6 server 2001:db8::201
```

```
64 bytes from 2001:db8::201: icmp_seq=0, time=0ms
```

```
64 bytes from 2001:db8::201: icmp_seq=1, time=0ms
```

```
64 bytes from 2001:db8::201: icmp_seq=2, time=0ms
```

```
64 bytes from 2001:db8::201: icmp_seq=3, time=0ms
```

```
64 bytes from 2001:db8::201: icmp_seq=4, time=0ms
```

```
Sent 5 packets, received 5 OK, 0 bad
```

You can configure the following properties of the issued ICMP packets:

6.5.3 VeriPHY

This section is used for running the VeriPHY Cable Diagnostics. Press "Start" to run the diagnostics. This will take approximately 5 seconds. If all ports are selected, this can take approximately 15 seconds. When completed, the page refreshes automatically, and you can view the cable diagnostics results in the cable status table. Note that VeriPHY is only accurate for cables of length 7 -140 meters. 10 and 100 Mbps ports will be linked down while running VeriPHY. Therefore, running VeriPHY on a 10 or 100 Mbps management port will cause the switch to stop responding until VeriPHY is complete.

Web Interface

To configure VeriPHY Cable Diagnostics in the web interface:

1. Specify Port which want to check.
2. Click Start.

Figure 5-5.3: The VeriPHY

Cable Status								
Port	Pair A	Length A	Pair B	Length B	Pair C	Length C	Pair D	Length D
1	--	--	--	--	--	--	--	--
2	--	--	--	--	--	--	--	--
3	--	--	--	--	--	--	--	--
4	--	--	--	--	--	--	--	--
5	--	--	--	--	--	--	--	--
6	--	--	--	--	--	--	--	--

Parameter description:

Port:

The port where you are requesting VeriPHY Cable Diagnostics.

Cable Status:

Port: Port number.

Pair: The status of the cable pair.

Length: The length (in meters) of the cable pair.

A. Glossary of Web-based Management

A

ACE

ACE is an acronym for Access Control Entry. It describes access permission associated with a particular ACE ID.

There are three ACE frame types (Ethernet Type, ARP, and IPv4) and two ACE actions (permit and deny). The ACE also contains many detailed, different parameter options that are available for individual application.

ACL

ACL is an acronym for Access Control List. It is the list table of ACEs, containing access control entries that specify individual users or groups permitted or denied to specific traffic objects, such as a process or a program.

Each accessible traffic object contains an identifier to its ACL. The privileges determine whether there are specific traffic object access rights.

ACL implementations can be quite complex, for example, when the ACEs are prioritized for the various situation. In networking, the ACL refers to a list of service ports or network services that are available on a host or server, each with a list of hosts or servers permitted or denied to use the service. ACL can generally be configured to control inbound traffic, and in this context, they are similar to firewalls.

There are 3 web-pages associated with the manual ACL configuration:

ACL|Access Control List: The web page shows the ACEs in a prioritized way, highest (top) to lowest (bottom). Default the table is empty. An ingress frame will only get a hit on one ACE even though there are more matching ACEs. The first matching ACE will take action (permit/deny) on that frame and a counter associated with that ACE is incremented. An ACE can be associated with a Policy, 1 ingress port, or any ingress port (the whole switch). If an ACE Policy is created then that Policy can be associated with a group of ports under the "Ports" web-page. There are number of parameters that can be configured with an ACE. Read the Web page help text to get further information for each of them. The maximum number of ACEs is 64.

ACL|Ports: The ACL Ports configuration is used to assign a Policy ID to an ingress port. This is useful to group ports to obey the same traffic rules. Traffic Policy is created under the "Access Control List" - page. You can you also set up specific traffic properties (Action / Rate Limiter / Port copy, etc) for each ingress port. They will though only apply if the frame gets past the ACE matching without getting matched. In that case a counter associated with that port is incremented. See the Web page help text for each specific port property.

ACL|Rate Limiters: Under this page you can configure the rate limiters. There can be 15 different rate limiters, each ranging from 1-1024K packets per seconds. Under "Ports" and "Access Control List" web-pages you can assign a Rate Limiter ID to the ACE(s) or ingress port(s).

AES

AES is an acronym for Advanced Encryption Standard. The encryption key protocol is applied in 802.1i standard to improve WLAN security. It is an encryption standard by the U.S. government, which will replace DES and 3DES. AES has a fixed block size of 128 bits and a key size of 128, 192, or 256 bits.

APS

APS is an acronym for Automatic Protection Switching. This protocol is used to secure that switching is done bidirectional in the two ends of a protection group, as defined in G.8031.

Aggregation

A. Glossary of Web-based Management

Using multiple ports in parallel to increase the link speed beyond the limits of a port and to increase the redundancy for higher availability.

(Also Port Aggregation, Link Aggregation).

ARP

ARP is an acronym for Address Resolution Protocol. It is a protocol that used to convert an IP address into a physical address, such as an Ethernet address. ARP allows a host to communicate with other hosts when only the Internet address of its neighbors is known. Before using IP, the host sends a broadcast ARP request containing the Internet address of the desired destination system.

ARP Inspection

ARP Inspection is a secure feature. Several types of attacks can be launched against a host or devices connected to Layer 2 networks by "poisoning" the ARP caches. This feature is used to block such attacks. Only valid ARP requests and responses can go through the switch device.

Auto-Negotiation

Auto-negotiation is the process where two different devices establish the mode of operation and the speed settings that can be shared by those devices for a link.

C

CC

CC is an acronym for Continuity Check. It is a MEP functionality that is able to detect loss of continuity in a network by transmitting CCM frames to a peer MEP.

CCM

CCM is an acronym for Continuity Check Message. It is a OAM frame transmitted from a MEP to it's peer MEP and used to implement CC functionality.

CDP

CDP is an acronym for Cisco Discovery Protocol.

D

DEI

DEI is an acronym for Drop Eligible Indicator. It is a 1-bit field in the VLAN tag.

DES

DES is an acronym for Data Encryption Standard. It provides a complete description of a mathematical algorithm for encrypting (enciphering) and decrypting (deciphering) binary coded information.

Encrypting data converts it to an unintelligible form called cipher. Decrypting cipher converts the data back to its original form called plaintext. The algorithm described in this standard specifies both enciphering and deciphering operations which are based on a binary number called a key.

DHCP

DHCP is an acronym for Dynamic Host Configuration Protocol. It is a protocol used for assigning dynamic IP addresses to devices on a network.

DHCP used by networked computers (clients) to obtain IP addresses and other parameters such as the default gateway, subnet mask, and IP addresses of DNS servers from a DHCP server.

The DHCP server ensures that all IP addresses are unique, for example, no IP address is assigned to a second client while the first client's assignment is valid (its lease has not expired). Therefore, IP address pool management is done by the server and not by a human network administrator.

Dynamic addressing simplifies network administration because the software keeps track of IP addresses rather than requiring an administrator to manage the task. This means that a new computer can be added to a network without the hassle of manually assigning it a unique IP address.

DHCP Relay

DHCP Relay is used to forward and to transfer DHCP messages between the clients and the server when they are not on the same subnet domain.

The DHCP option 82 enables a DHCP relay agent to insert specific information into a DHCP request packets when forwarding client DHCP packets to a DHCP server and remove the specific information from a DHCP reply packets when forwarding server DHCP packets to a DHCP client. The DHCP server can use this information to implement IP address or other assignment policies. Specifically the option works by setting two sub-options: Circuit ID (option 1) and Remote ID (option2). The Circuit ID sub-option is supposed to include information specific to which circuit the request came in on. The Remote ID sub-option was designed to carry information relating to the remote host end of the circuit.

The definition of Circuit ID in the switch is 4 bytes in length and the format is "vlan_id" "module_id" "port_no". The parameter of "vlan_id" is the first two bytes represent the VLAN ID. The parameter of "module_id" is the third byte for the module ID (in standalone switch it always equal 0). The parameter of "port_no" is the fourth byte and it means the port number. The Remote ID is 6 bytes in length, and the value is equal the DHCP relay agents MAC address.

DHCP Snooping

DHCP Snooping is used to block intruder on the untrusted ports of the switch device when it tries to intervene by injecting a bogus DHCP reply packet to a legitimate conversation between the DHCP client and server.

DNS

DNS is an acronym for Domain Name System. It stores and associates many types of information with domain names. Most importantly, DNS translates human-friendly domain names and computer hostnames into computer-friendly IP addresses. For example, the domain name www.example.com might translate to 192.168.0.1.

DoS

DoS is an acronym for Denial of Service. In a denial-of-service (DoS) attack, an attacker attempts to prevent legitimate users from accessing information or services. By targeting at network sites or network connection, an attacker may be able to prevent network users from accessing email, web sites, online accounts (banking, etc.), or other services that rely on the affected computer.

Dotted Decimal Notation

Dotted Decimal Notation refers to a method of writing IP addresses using decimal numbers and dots as separators between octets. An IPv4 dotted decimal address has the form x.y.z.w, where x, y, z, and w are decimal numbers between 0 and 255.

DSCP

DSCP is an acronym for Differentiated Services Code Point. It is a field in the header of IP packets for packet classification purposes.

E

EEE

EEE is an abbreviation for Energy Efficient Ethernet defined in IEEE 802.3az.

EPS

EPS is an abbreviation for Ethernet Protection Switching defined in ITU/T G.8031.

Ethernet Type

Ethernet Type, or EtherType, is a field in the Ethernet MAC header, defined by the Ethernet networking standard. It is used to indicate which protocol is being transported in an Ethernet frame.

F**FTP**

FTP is an acronym for File Transfer Protocol. It is a transfer protocol that uses the Transmission Control Protocol (TCP) and provides file writing and reading. It also provides directory service and security features.

Fast Leave

Multicast snooping Fast Leave processing allows the switch to remove an interface from the forwarding-table entry without first sending out group specific queries to the interface. The VLAN interface is pruned from the multicast tree for the multicast group specified in the original leave message. Fast-leave processing ensures optimal bandwidth management for all hosts on a switched network, even when multiple multicast groups are in use simultaneously. This processing applies to IGMP and MLD.

H**HTTP**

HTTP is an acronym for Hypertext Transfer Protocol. It is a protocol that used to transfer or convey information on the World Wide Web (WWW).

HTTP defines how messages are formatted and transmitted, and what actions Web servers and browsers should take in response to various commands. The other main standard that controls how the World Wide Web works is HTML, which covers how Web pages are formatted and displayed.

Any Web server machine contains, in addition to the Web page files it can serve, an HTTP daemon, a program that is designed to wait for HTTP requests and handle them when they arrive. The Web browser is an HTTP client, sending requests to server machines. An HTTP client initiates a request by establishing a Transmission Control Protocol (TCP) connection to a particular port on a remote host (port 80 by default). An HTTP server listening on that port waits for the client to send a request message.

HTTPS

HTTPS is an acronym for Hypertext Transfer Protocol over Secure Socket Layer. It is used to indicate a secure HTTP connection.

HTTPS provide authentication and encrypted communication and is widely used on the World Wide Web for security-sensitive communication such as payment transactions and corporate logons.

HTTPS is really just the use of Netscape's Secure Socket Layer (SSL) as a sublayer under its regular HTTP application layering. (HTTPS uses port 443 instead of HTTP port 80 in its interactions with the lower layer, TCP/IP.) SSL uses a 40-bit key size for the RC4 stream encryption algorithm, which is considered an adequate degree of encryption for commercial exchange.

I**ICMP**

ICMP is an acronym for Internet Control Message Protocol. It is a protocol that generated the error response, diagnostic or routing purposes. ICMP messages generally contain information about routing difficulties or simple exchanges such as time-stamp or echo transactions.

IEEE 802.1X

IEEE 802.1X is an IEEE standard for port-based Network Access Control. It provides authentication to devices attached to a LAN port, establishing a point-to-point connection or preventing access from that port if authentication fails. With 802.1X, access to all switch ports can be centrally controlled from a server, which means that authorized users can use the same credentials for authentication from any point within the network.

IGMP

IGMP is an acronym for Internet Group Management Protocol. It is a communications protocol used to manage the membership of Internet Protocol multicast groups. IGMP is used by IP hosts and adjacent multicast routers to establish multicast group memberships. It is an integral part of the IP multicast specification, like ICMP for unicast connections. IGMP can be used for online video and gaming, and allows more efficient use of resources when supporting these uses.

IGMP Querier

A router sends IGMP Query messages onto a particular link. This router is called the Querier.

IMAP

IMAP is an acronym for Internet Message Access Protocol. It is a protocol for email clients to retrieve email messages from a mail server.

IMAP is the protocol that IMAP clients use to communicate with the servers, and SMTP is the protocol used to transport mail to an IMAP server.

The current version of the Internet Message Access Protocol is IMAP4. It is similar to Post Office Protocol version 3 (POP3), but offers additional and more complex features. For example, the IMAP4 protocol leaves your email messages on the server rather than downloading them to your computer. If you wish to remove your messages from the server, you must use your mail client to generate local folders, copy messages to your local hard drive, and then delete and expunge the messages from the server.

IP

IP is an acronym for Internet Protocol. It is a protocol used for communicating data across an internet network.

IP is a "best effort" system, which means that no packet of information sent over is assured to reach its destination in the same condition it was sent. Each device connected to a Local Area Network (LAN) or Wide Area Network (WAN) is given an Internet Protocol address, and this IP address is used to identify the device uniquely among all other devices connected to the extended network.

The current version of the Internet protocol is IPv4, which has 32-bits Internet Protocol addresses allowing for in excess of four billion unique addresses. This number is reduced drastically by the practice of webmasters taking addresses in large blocks, the bulk of which remain unused. There is a rather substantial movement to adopt a new version of the Internet Protocol, IPv6, which would have 128-bits Internet Protocol addresses. This number can be represented roughly by a three with thirty-nine zeroes after it. However, IPv4 is still the protocol of choice for most of the Internet.

IPMC

IPMC is an acronym for IP Multicast.

IP Source Guard

IP Source Guard is a secure feature used to restrict IP traffic on DHCP snooping untrusted ports by filtering traffic based on the DHCP Snooping Table or manually configured IP Source Bindings. It helps prevent IP spoofing attacks when a host tries to spoof and use the IP address of another host.

L

LACP

LACP is an IEEE 802.3ad standard protocol. The Link Aggregation Control Protocol, allows bundling several physical ports together to form a single logical port.

LLC

The IEEE 802.2 Logical Link Control (LLC) protocol provides a link mechanism for upper layer protocols. It is the upper sub-layer of the Data Link Layer and provides multiplexing mechanisms that make it possible for several network protocols (IP, IPX) to coexist within a multipoint network. LLC header consists of 1 byte DSAP (Destination Service Access Point), 1 byte SSAP (Source Service Access Point), 1 or 2 bytes Control field followed by LLC information.

LLDP

LLDP is an IEEE 802.1ab standard protocol.

The Link Layer Discovery Protocol(LLDP) specified in this standard allows stations attached to an IEEE 802 LAN to advertise, to other stations attached to the same IEEE 802 LAN, the major capabilities provided by the system incorporating that station, the management address or addresses of the entity or entities that provide management of those capabilities, and the identification of the stations point of attachment to the IEEE 802 LAN required by those management entity or entities. The information distributed via this protocol is stored by its recipients in a standard Management Information Base (MIB), making it possible for the information to be accessed by a Network Management System (NMS) using a management protocol such as the Simple Network Management Protocol (SNMP).

LLDP-MED

LLDP-MED is an extension of IEEE 802.1ab and is defined by the telecommunication industry association (TIA-1057).

LOC

LOC is an acronym for Loss Of Connectivity and is detected by a MEP and is indicating lost connectivity in the network. Can be used as a switch criteria by EPS

M

MAC Table

Switching of frames is based upon the DMAC address contained in the frame. The switch builds up a table that maps MAC addresses to switch ports for knowing which ports the frames should go to (based upon the DMAC address in the frame). This table contains both static and dynamic entries. The static entries are configured by the network administrator if the administrator wants to do a fixed mapping between the DMAC address and switch ports.

The frames also contain a MAC address (SMAC address), which shows the MAC address of the equipment sending the frame. The SMAC address is used by the switch to automatically update the MAC table with these dynamic MAC addresses. Dynamic entries are removed from the MAC table if no frame with the corresponding SMAC address have been seen after a configurable age time.

MEP

MEP is an acronym for Maintenance Entity Endpoint and is an endpoint in a Maintenance Entity Group (ITU-T Y.1731).

MD5

MD5 is an acronym for Message-Digest algorithm 5. MD5 is a message digest algorithm, used cryptographic hash function with a 128-bit hash value. It was designed by Ron Rivest in 1991. MD5 is officially defined in RFC 1321 - The MD5 Message-Digest Algorithm.

Mirroring

For debugging network problems or monitoring network traffic, the switch system can be configured to mirror frames from multiple ports to a mirror port. (In this context, mirroring a frame is the same as copying the frame.)

Both incoming (source) and outgoing (destination) frames can be mirrored to the mirror port.

MLD

MLD is an acronym for Multicast Listener Discovery for IPv6. MLD is used by IPv6 routers to discover multicast listeners on a directly attached link, much as IGMP is used in IPv4. The protocol is embedded in ICMPv6 instead of using a separate protocol.

MVR

Multicast VLAN Registration (MVR) is a protocol for Layer 2 (IP)-networks that enables multicast-traffic from a source VLAN to be shared with subscriber-VLANs.

The main reason for using MVR is to save bandwidth by preventing duplicate multicast streams being sent in the core network, instead the stream(s) are received on the MVR-VLAN and forwarded to the VLANs where hosts have requested it/them(Wikipedia).

N

NAS

NAS is an acronym for Network Access Server. The NAS is meant to act as a gateway to guard access to a protected source. A client connects to the NAS, and the NAS connects to another resource asking whether the client's supplied credentials are valid. Based on the answer, the NAS then allows or disallows access to the protected resource. An example of a NAS implementation is IEEE 802.1X.

NetBIOS

NetBIOS is an acronym for Network Basic Input/Output System. It is a program that allows applications on separate computers to communicate within a Local Area Network (LAN), and it is not supported on a Wide Area Network (WAN).

The NetBIOS giving each computer in the network both a NetBIOS name and an IP address corresponding to a different host name, provides the session and transport services described in the Open Systems Interconnection (OSI) model.

NFS

NFS is an acronym for Network File System. It allows hosts to mount partitions on a remote system and use them as though they are local file systems.

NFS allows the system administrator to store resources in a central location on the network, providing authorized users continuous access to them, which means NFS supports sharing of files, printers, and other resources as persistent storage over a computer network.

NTP

NTP is an acronym for Network Time Protocol, a network protocol for synchronizing the clocks of computer systems. NTP uses UDP (datagrams) as transport layer.

O

OAM

OAM is an acronym for Operation Administration and Maintenance.

It is a protocol described in ITU-T Y.1731 used to implement carrier Ethernet functionality. MEP functionality like CC and RDI is based on this

Optional TLVs.

A LLDP frame contains multiple TLVs

For some TLVs it is configurable if the switch shall include the TLV in the LLDP frame. These TLVs are known as optional TLVs. If an optional TLVs is disabled the corresponding information is not included in the LLDP frame.

OUI

OUI is the organizationally unique identifier. An OUI address is a globally unique identifier assigned to a vendor by IEEE. You can determine which vendor a device belongs to according to the OUI address which forms the first 24 bits of a MAC address.

P

PCP

PCP is an acronym for Priority Code Point. It is a 3-bit field storing the priority level for the 802.1Q frame. It is also known as User Priority.

PD

PD is an acronym for Powered Device. In a PoE system the power is delivered from a PSE (power sourcing equipment) to a remote device. The remote device is called a PD.

PHY

PHY is an abbreviation for Physical Interface Transceiver and is the device that implement the Ethernet physical layer (IEEE-802.3).

PING

ping is a program that sends a series of packets over a network or the Internet to a specific computer in order to generate a response from that computer. The other computer responds with an acknowledgment that it received the packets. Ping was created to verify whether a specific computer on a network or the Internet exists and is connected.

ping uses Internet Control Message Protocol (ICMP) packets. The PING Request is the packet from the origin computer, and the PING Reply is the packet response from the target.

PoE

PoE is an acronym for Power Over Ethernet.

Power Over Ethernet is used to transmit electrical power, to remote devices over standard Ethernet cable. It could for example be used for powering IP telephones, wireless LAN access points and other equipment, where it would be difficult or expensive to connect the equipment to main power supply.

Policer

A policer can limit the bandwidth of received frames. It is located in front of the ingress queue.

POP3

POP3 is an acronym for Post Office Protocol version 3. It is a protocol for email clients to retrieve email messages from a mail server.

POP3 is designed to delete mail on the server as soon as the user has downloaded it. However, some implementations allow users or an administrator to specify that mail be saved for some period of time. POP can be thought of as a "store-and-forward" service.

An alternative protocol is Internet Message Access Protocol (IMAP). IMAP provides the user with more capabilities for retaining e-mail on the server and for organizing it in folders on the server. IMAP can be thought of as a remote file server.

POP and IMAP deal with the receiving of e-mail and are not to be confused with the Simple Mail Transfer Protocol (SMTP). You send e-mail with SMTP, and a mail handler receives it on your recipient's behalf. Then the mail is read using POP or IMAP. IMAP4 and POP3 are the two most prevalent Internet standard protocols for e-mail retrieval. Virtually all modern e-mail clients and servers support both.

Private VLAN

In a private VLAN, communication between ports in that private VLAN is not permitted. A VLAN can be configured as a private VLAN.

PTP

PTP is an acronym for Precision Time Protocol, a network protocol for synchronizing the clocks of computer systems.

Q

QCE

QCE is an acronym for QoS Control Entry. It describes QoS class associated with a particular QCE ID.

There are six QCE frame types: Ethernet Type, VLAN, UDP/TCP Port, DSCP, TOS, and Tag Priority. Frames can be classified by one of 4 different QoS classes: "Low", "Normal", "Medium", and "High" for individual application.

QCL

QCL is an acronym for QoS Control List. It is the list table of QCEs, containing QoS control entries that classify to a specific QoS class on specific traffic objects.

Each accessible traffic object contains an identifier to its QCL. The privileges determine specific traffic object to specific QoS class.

QL

QL In SyncE this is the Quality Level of a given clock source. This is received on a port in a SSM indicating the quality of the clock received in the port.

QoS

QoS is an acronym for Quality of Service. It is a method to guarantee a bandwidth relationship between individual applications or protocols.

A communications network transports a multitude of applications and data, including high-quality video and delay-sensitive data such as real-time voice. Networks must provide secure, predictable, measurable, and sometimes guaranteed services.

Achieving the required QoS becomes the secret to a successful end-to-end business solution. Therefore, QoS is the set of techniques to manage network resources.

R

RARP

RARP is an acronym for Reverse Address Resolution Protocol. It is a protocol that is used to obtain an IP address for a given hardware address, such as an Ethernet address. RARP is the complement of ARP.

RADIUS

RADIUS is an acronym for Remote Authentication Dial In User Service. It is a networking protocol that provides centralized access, authorization and accounting management for people or computers to connect and use a network service.

RDI

RDI is an acronym for Remote Defect Indication. It is a OAM functionality that is used by a MEP to indicate defect detected to the remote peer MEP

RSTP

In 1998, the IEEE with document 802.1w introduced an evolution of STP: the Rapid Spanning Tree Protocol, which provides for faster spanning tree convergence after a topology change. Standard IEEE 802.1D-2004 now incorporates RSTP and obsoletes STP, while at the same time being backwards-compatible with STP.

S

SHA

SHA is an acronym for Secure Hash Algorithm. It designed by the National Security Agency (NSA) and published by the NIST as a U.S. Federal Information Processing Standard. Hash algorithms compute a fixed-length digital representation (known as a message digest) of an input data sequence (the message) of any length.

Shaper

A shaper can limit the bandwidth of transmitted frames. It is located after the ingress queues.

SMTP

SMTP is an acronym for Simple Mail Transfer Protocol. It is a text-based protocol that uses the Transmission Control Protocol (TCP) and provides a mail service modeled on the FTP file transfer service. SMTP transfers mail messages between systems and notifications regarding incoming mail.

SNAP

The SubNetwork Access Protocol (SNAP) is a mechanism for multiplexing, on networks using IEEE 802.2 LLC, more protocols than can be distinguished by the 8-bit 802.2 Service Access Point (SAP) fields. SNAP supports identifying protocols by Ethernet type field values; it also supports vendor-private protocol identifier.

SNMP

SNMP is an acronym for Simple Network Management Protocol. It is part of the Transmission Control Protocol/Internet Protocol (TCP/IP) protocol for network management. SNMP allow diverse network objects to participate in a network management architecture. It enables network management systems to learn network problems by receiving traps or change notices from network devices implementing SNMP.

SNTP

SNTP is an acronym for Simple Network Time Protocol, a network protocol for synchronizing the clocks of computer systems. SNTP uses UDP (datagrams) as transport layer.

SSID

Service Set Identifier is a name used to identify the particular 802.11 wireless LANs to which a user wants to attach. A client device will receive broadcast messages from all access points within range advertising their SSIDs, and can choose one to connect to based on pre-configuration, or by displaying a list of SSIDs in range and asking the user to select one (Wikipedia).

SSH

SSH is an acronym for Secure Shell. It is a network protocol that allows data to be exchanged using a secure channel between two networked devices. The encryption used by SSH provides confidentiality and integrity of data over an insecure network. The goal of SSH was to replace the earlier rlogin, TELNET and rsh protocols, which did not provide strong authentication or guarantee confidentiality (Wikipedia).

SSM

SSM In SyncE this is an abbreviation for Synchronization Status Message and is containing a QL indication.

STP

Spanning Tree Protocol is an OSI layer-2 protocol which ensures a loop free topology for any bridged LAN. The original STP protocol is now obsolete by RSTP.

SyncE

SyncE Is an abbreviation for Synchronous Ethernet. This functionality is used to make a network 'clock frequency' synchronized. Not to be confused with real time clock synchronized (IEEE 1588).

T

TACACS+

TACACS+ is an acronym for Terminal Access Controller Access Control System Plus. It is a networking protocol which provides access control for routers, network access servers and other networked computing devices via one or more centralized servers. TACACS+ provides separate authentication, authorization and accounting services.

Tag Priority

Tag Priority is a 3-bit field storing the priority level for the 802.1Q frame.

TCP

TCP is an acronym for Transmission Control Protocol. It is a communications protocol that uses the Internet Protocol (IP) to exchange the messages between computers.

The TCP protocol guarantees reliable and in-order delivery of data from sender to receiver and distinguishes data for multiple connections by concurrent applications (for example, Web server and e-mail server) running on the same host.

The applications on networked hosts can use TCP to create connections to one another. It is known as a connection-oriented protocol, which means that a connection is established and maintained until such time as the message or messages to be exchanged by the application programs at each end have been exchanged. TCP is responsible for ensuring that a message is divided into the packets that IP manages and for reassembling the packets back into the complete message at the other end.

Common network applications that use TCP include the World Wide Web (WWW), e-mail, and File Transfer Protocol (FTP).

TELNET

TELNET is an acronym for TELeType NETwork. It is a terminal emulation protocol that uses the Transmission Control Protocol (TCP) and provides a virtual connection between TELNET server and TELNET client.

TFTP

TFTP is an acronym for Trivial File Transfer Protocol. It is transfer protocol that uses the User Datagram Protocol (UDP) and provides file writing and reading, but it does not provide directory service and security features.

U

UDP

UDP is an acronym for User Datagram Protocol. It is a communications protocol that uses the Internet Protocol (IP) to exchange the messages between computers.

UDP is an alternative to the Transmission Control Protocol (TCP) that uses the Internet Protocol (IP). Unlike TCP, UDP does not provide the service of dividing a message into packet datagrams, and UDP doesn't provide reassembling and sequencing of the packets. This means that the application program that uses UDP must be able to make sure that the entire message has arrived and is in the right order. Network applications that want to save processing time because they have very small data units to exchange may prefer UDP to TCP.

UDP provides two services not provided by the IP layer. It provides port numbers to help distinguish different user requests and, optionally, a checksum capability to verify that the data arrived intact.

Common network applications that use UDP include the Domain Name System (DNS), streaming media applications such as IPTV, Voice over IP (VoIP), and Trivial File Transfer Protocol (TFTP).

User Priority

User Priority is a 3-bit field storing the priority level for the 802.1Q frame. It is also known as PCP.

V

VLAN

Virtual LAN. A method to restrict communication between switch ports. VLANs can be used for the following applications:

VLAN unaware switching: This is the default configuration. All ports are VLAN unaware with Port VLAN ID 1 and members of VLAN 1. This means that MAC addresses are learned in VLAN 1, and the switch does not remove or insert VLAN tags.

VLAN aware switching: This is based on the IEEE 802.1Q standard. All ports are VLAN aware. Ports connected to VLAN aware switches are members of multiple VLANs and transmit tagged frames. Other ports are members of one VLAN, set up with this Port VLAN ID, and transmit untagged frames.

Provider switching: This is also known as Q-in-Q switching. Ports connected to subscribers are VLAN unaware, members of one VLAN, and set up with this unique Port VLAN ID. Ports connected to the service provider are VLAN aware, members of multiple VLANs, and set up to tag all frames. Untagged frames received on a subscriber port are forwarded to the provider port with a single VLAN tag. Tagged frames received on a subscriber port are forwarded to the provider port with a double VLAN tag.

VLAN ID

VLAN ID is a 12-bit field specifying the VLAN to which the frame belongs.

Voice VLAN

Voice VLAN is VLAN configured specially for voice traffic. By adding the ports with voice devices attached to voice VLAN, we can perform QoS-related configuration for voice data, ensuring the transmission priority of voice traffic and voice quality.